

Instruction Manual

Multifunction measuring instrument DS 300 with data logger



Short-form instruction manual
flow station

including



Short-form instruction manual
dew point set

Table of contents

| | Page |
|---|-------|
| Introduction | 2 |
| 1. Safety instructions | 3 |
| 2. Short-form instruction manual flow station | 4 |
| 3. Short-form instruction manual dew point se | 5 |
| 4. Key features | 6 |
| 5. Block diagram | 6 |
| 6. Calibration/adjustment | 7 |
| 7. Warranty | 7 |
| 8. Technical data DS 300 | 8 |
| 9. Technical data analogue modules | 9 |
| 10. Installation | 10-11 |
| 11. Connection without RS 485 | 12-25 |
| 12. Connection with RS 485 | 26-32 |
| 13. Connection with Ethernet interface | 33-34 |
| 13. Operation | 35-45 |
| 14. Scope of delivery | 45 |
| 15. Order information | 46-47 |
| EC declarations of conformity | 48-49 |
| Notes | 50-51 |
| Contact | 52 |

Introduction

Dear customer,

Thousands of customers buy our high standard products every year. There are a few good reasons for doing so:

- The cost-performance ratio - reliable quality at a fair price.
- We have the ideal solutions for your measuring tasks based on our expert experience gained over 20 years.
- Our high quality standard.
- Of course, our instruments carry the CE symbol required by the EU.
- We issue calibration certificates and hold seminars.
- Also after the purchase we do not leave you out in the cold - we offer a good after sales service.



Measuring instrument conforms with **DIN EN 61326**

6. Safety instructions

Observe measuring ranges of the sensors!

Observe the admissible storage and transportation temperature as well as the permitted operating temperature (e. g. protect the instrument from direct insolation)

Adjustments and calibrations should only be carried out by qualified employees from the measurement and control technology branch.

We offer you to take back the instruments DS 300, which you would like to dispose of.

The manufacturer cannot be held liable for any damage which occurs as a result of non-observance or non-compliance with these instructions. Should the device be tampered with in any matter other than a procedure which is described and specified in the manual, the warranty is cancelled and the manufacturer is exempt from liability.

CS Instruments GmbH offers no guarantee for the suitability for any other purpose and is not liable for errors which may have slipped into this operation manual. CS Instruments GmbH is also not liable for consequential damage resulting from the delivery, capability or use of this device.

Initiation (electrical connection)

When operating electrical instruments it is unavoidable that certain components are energised dangerously. Work at electrical installations or equipment is only allowed to be carried out by electrical technicians or instructed staff under the guidance and supervision of an electrical technician according to the electrical regulations.

Warning

Any non-observance of the warning notes may cause grievous bodily harm or property damages. Qualified staff has to be well familiar with all warnings according to this instruction manual. The correct and safe operation is subject to a proper transport, professional installation and accurate initiation. The following notes on safety are applied in order to stress safety relevant procedures in this instruction manual - every note is marked by a corresponding icon.



This symbol means: **Note!**

"**Note!**" marks activities or procedures which have a fundamental influence on correct operation. Any non-observance may possibly lead to subsequent damages.



This symbol means: **Warning!**

"**Warning!**" indicates activities or procedures which may lead to a safety risk for persons and property damages in case of non-observance.

1. Short-form instruction manual

Flow station DS 300 with VA 400 consumption sensor

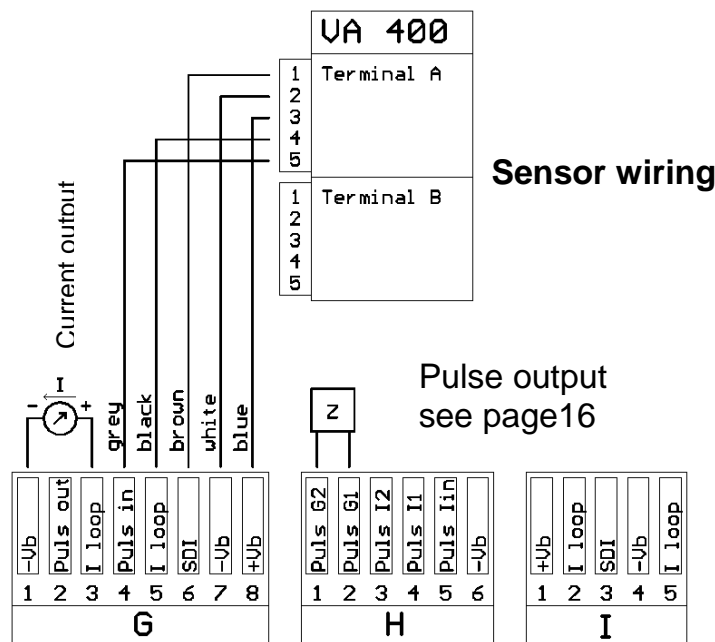

Connection power supply DS 300 see page 12

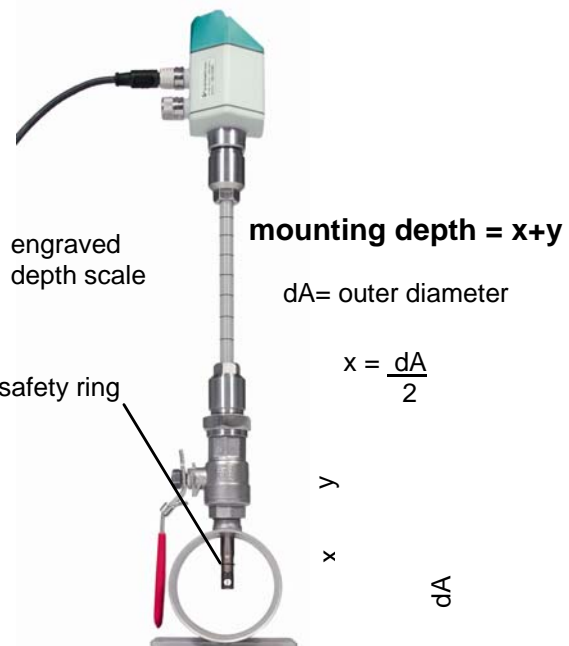

Please read carefully before starting the device!

1. Do not exceed pressure range > 50 bar
 2. Observe flow direction of the sensor
 3. Adapter sleeve must be tightened with a torque of 20-30 Nm
 4. Observe minimum values for the inlet section (15 x inner diameter) and for the outlet section (5 x inner diameter)
- For further information please see instruction manual VA 400.

Necessary adjustments via keypad DS 300 (see page 40)

- Adjust inner diameter of the pipe (menu sensor adjustment/consumption)
→ DS 300 automatically scales the analogue output 4...20 mA to the respective values for m³/h, m³/min and so on.
- Reference temperature and reference pressure (factory setting 20 °C, 1000 hPa):
All volume flow values (m³/h) and consumption values indicated in the display are related to 20 °C, 1000 hPa (according to ISO 1217 intake condition)
0 °C and 1013 hPa (=standard cubic meter) can also be entered as a reference.
Do not enter the operation pressure or the operation temperature under reference conditions!



2. Short-form instruction manual Dew point set FA 410 with alarm

Sensor wiring

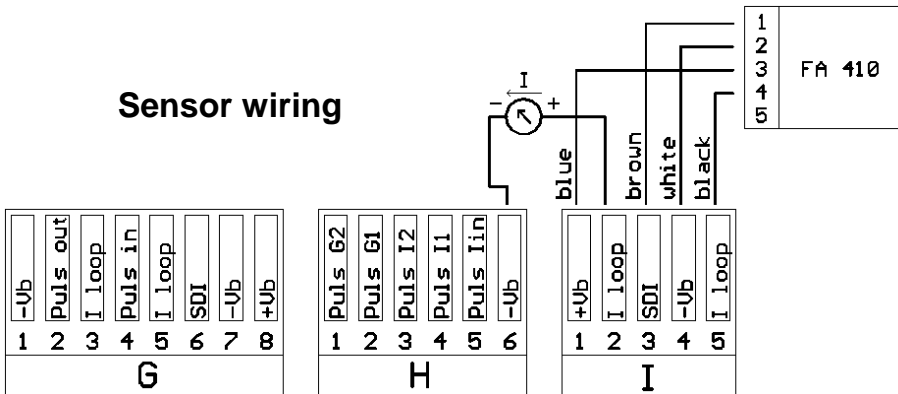

Power supply alarm connection:

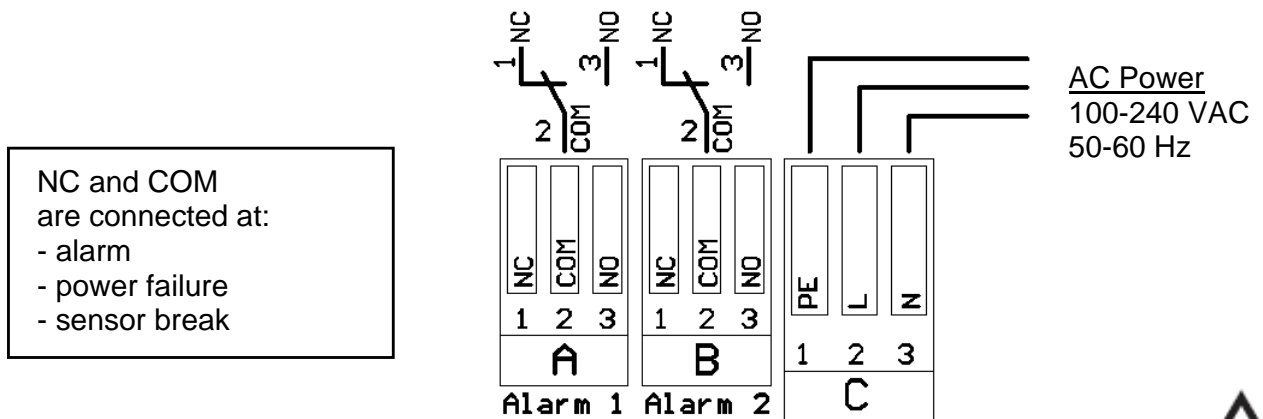

Please read carefully before starting the device!

1. Attention: Do not exceed pressure range of > 50 bar with standard version. (Up to 350 bar in case of special version).
2. Important: Before installation briefly bleed the compressed air in order to remove condensate and particles. This prevents soiling of FA 410. Standing air leads to long measuring times.

Dew point set DS 300 with FA 410 with alarm unit (option)

- Dew point set ready for plug in and fully configured, no further adjustments necessary .
- Alarm values are programmed on our premises:
Dew point set -20...+50 °Ctd to alarm 1: 8 °Ctd, alarm 2: 12 °Ctd
Dew point set -80...+20 °Ctd to alarm 1: -40 °Ctd, alarm 2: -35 °Ctd
in case of alarm unit option: Alarm 1 continuous red light
Alarm 2 buzzer

The alarm values can easily be changed via the keypad of DS 300 (menu, Alarm 1, Alarm 2, see page 41).

3. Key functions of DS 300

- Graphic display for easy user interface
- Flexible power supply: 100 to 240 VAC / 50 to 60Hz
- 2 inputs for CS consumption / dew point sensors
- 2 relais outputs for alarm
- USB interface
- Wall or panel mountable casing
- PC software for easy configuration and evaluation of the data
- Option RS 485 interface / Modbus
- Option data logger function for 1,000,000 values
- Option analogue input module (0...20 mA, 0...10 V, Pt100, TC)

4. Block diagram

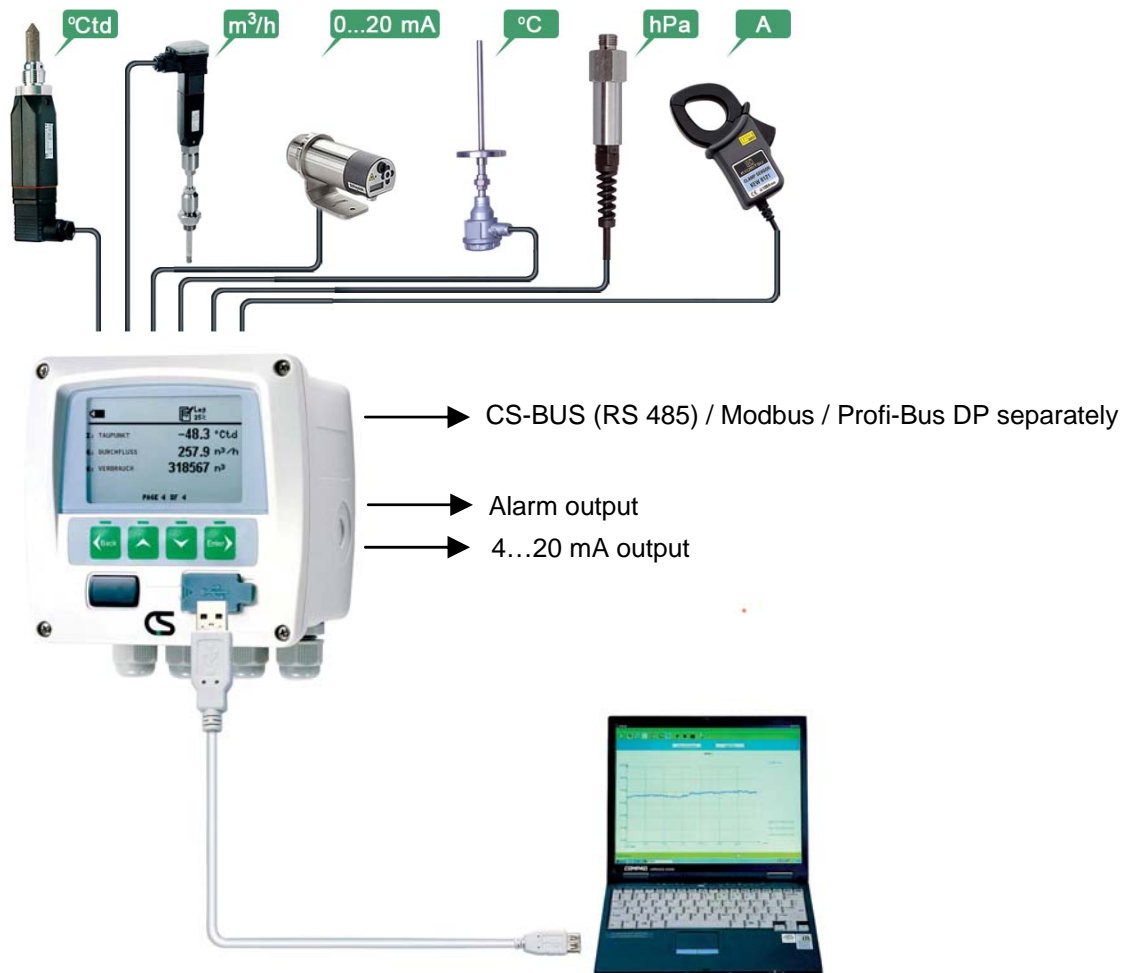

5. Calibration/adjustment

According to DIN ISO certification of the measuring instruments we recommend to calibrate and if applicable to adjust the instruments regularly at the manufacturer. The calibration intervals should comply with your internal specification. According to DIN ISO we recommend a calibration interval of one year for the instrument DS 300 including probes.

7. Warranty

If you have reason for complaint we will of course repair any faults free of charge if it can be proven that they are manufacturing faults. The fault should be reported immediately after it has been found and within the warranty time guaranteed by us. Excluded from this warranty is damage caused by improper use and non adherence to the instruction manual.

The warranty is also cancelled once the instrument has been opened - as far as this has not been mentioned in the instruction manual for maintenance purposes - or if the serial number in the instrument has been changed, damaged or removed.

The warranty time for DS 300 with accessories is 12 months. Warranty services do not extend the warranty time.

If in addition to the warranty service necessary repairs, adjustments or similar are carried out the warranty services are free of charge but there is a charge for other services such as transport and packaging costs. Other claims, especially those for damage occurring outside the instrument, are not included unless responsibility is legally binding.

After sales service after the warranty time has elapsed

We are of course there for you even after the warranty time has elapsed. In case of malfunctions please send us the instrument with a short-form description of the fault. Please do not forget to indicate your telephone number so that we can call you in case of any questions.

8. Technical data

| | |
|---|---|
| Housing | Dimensions: 92 x 92 x 55 mm |
| Sensor inputs | 2 inputs for dew point and consumption probes |
| Interface | USB to PC |
| SDI interface | internal communication with CS probes VA/FA 300/400 max. cable length 200 m |
| Keypad | 4 keys |
| Voltage supply | 100 240 VAC / 50-60 Hz / 10 VA |
| Display | Graphic display, 160 x 100 pixels |
| Accuracy | Please see probe specifications |
| Adjustments | The following settings are possible via DS 300 configuration software/USB: <ul style="list-style-type: none"> ▪ Display: Value, size and position ▪ Channel descriptions ▪ Alarm settings: Hysteresis, direction, selection of measuring channel ▪ Admission code for certain menus |
| Alarm output | 2 relays, 230 VAC, 3 A |
| Analogue output | Connection of the 4-20 mA signals of the CS dew point and consumption sensors see pages 14-26 |
| Rear connectors (cross sections of pipe) | Supply: AWG12 ... AWG24, 0.2 ... 2,5 mm ² Signals: AWG16 ... AWG28, 0.14 ... 1.5 mm ² |
| Operating temperature | 0 ... 50 °C |
| Storage temperature | -20 ... 70 °C |
| Weight | 520 g |
| Housing for wall mounting | Dimensions: 118 x 115 x 93 mm; 4 PG inputs, pipe diameter: 4.5 ... 8,0 mm; protection class: IP 65 |
| Options: | |
| Data logger | <ul style="list-style-type: none"> ▪ Up to 1,000,000 values ▪ Programmable start time or manual start ▪ Measuring rate: 1 s ... 1 h adjustable ▪ Average value storing |
| Analogue input module | 2 additional sensor inputs for connection of pressure sensors, temperature sensors, clamp-on-ammeters, third-party sensors with 4... 20 mA, 0... 10V, Pt 100, NiCr-Ni |
| RS 485/Modbus | Up to 64 x DS 300 can be connected to a computer system. Maximum cable length 1,000 m. |
| Ethernet interface | RJ45 socket for connection to computer networks integrated in DS 300 |
| CS Software | For indication of measured values in graphic and table form |

9. Technical data analogue input module

| | | |
|---|--|------------------------------------|
| Sensor inputs | | |
| Signal current (0...20mA/4...20mA) internal or external voltage supply | Measuring range | 0...20 mA |
| | Resolution | 0.0001 mA |
| | Accuracy | $\pm 0.003 \text{ mA} \pm 0.05 \%$ |
| | Input resistance | 50 Ω |
| Signal voltage (0...1V) | Measuring range | 0...1 V |
| | Resolution | 0.05 mV |
| | Accuracy | $\pm 0.2 \text{ mV} \pm 0.05 \%$ |
| | Input resistance | 10 M Ω |
| Signal voltage (0...10V) | Measuring range | 0...10 V |
| | Resolution | 0.5 mV |
| | Accuracy | $\pm 2 \text{ mV} \pm 0.05 \%$ |
| | Input resistance | 10 M Ω |
| RTD Pt100 | Measuring range | -200...900 °C |
| | Resolution | 0.1 °C |
| | Accuracy | $\pm 0.2 \text{ °C}$ |
| RTD Pt1000 | Measuring range | -200...900 °C |
| | Resolution | 0.1 °C |
| | Accuracy | $\pm 0.2 \text{ °C}$ |
| Thermocouple K | Measuring range | -270...1372 °C |
| Thermocouple J | Measuring range | -210...1200 °C |
| Thermocouple T | Measuring range | -265...400 °C |
| Thermocouple E | Measuring range | -200...1000 °C |
| | Resolution | 0.1 °C |
| | Accuracy | $\pm 0.5 \text{ °C} \pm 0.05 \%$ |
| | Input resistance | 10 M Ω |
| Supply for external sensors | For 2 external sensors 24 V / max. 25 mA each | |

10. Installation

Panel / wall mounting

The instrument can either be mounted into a panel or - if ordered with the optional wall casing - on a wall. Please refer to the drawings below for details.

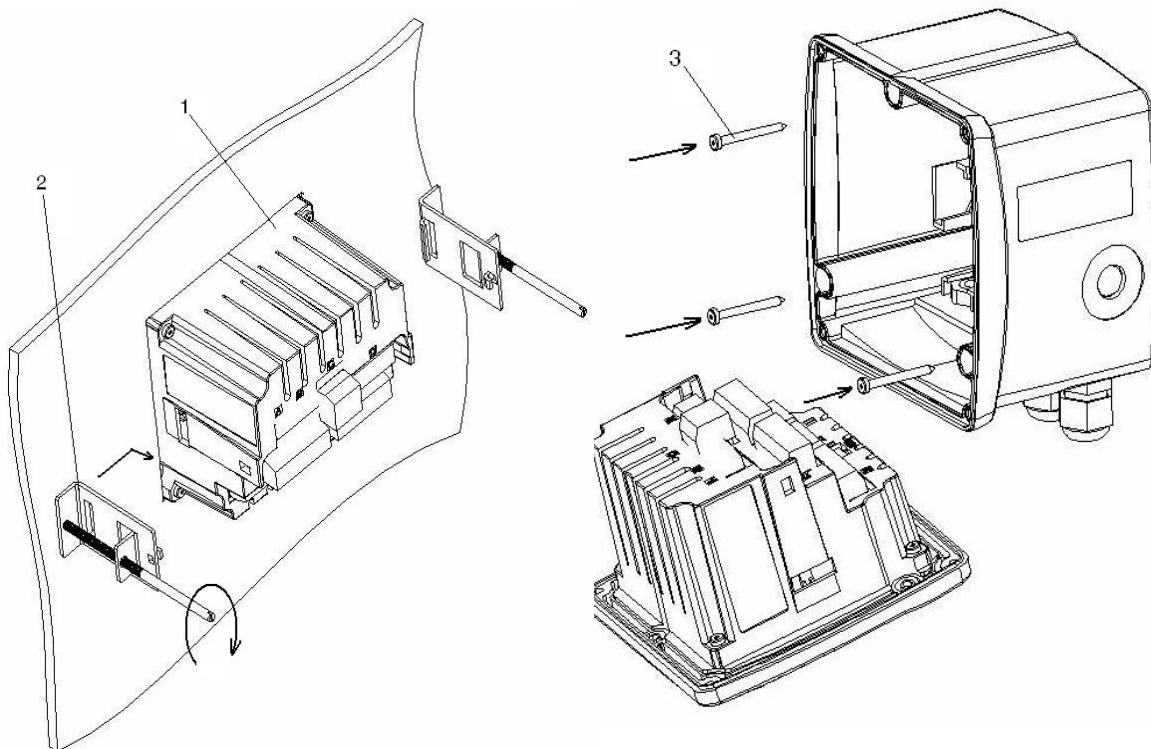

Figure: Panel and wall mountable housing

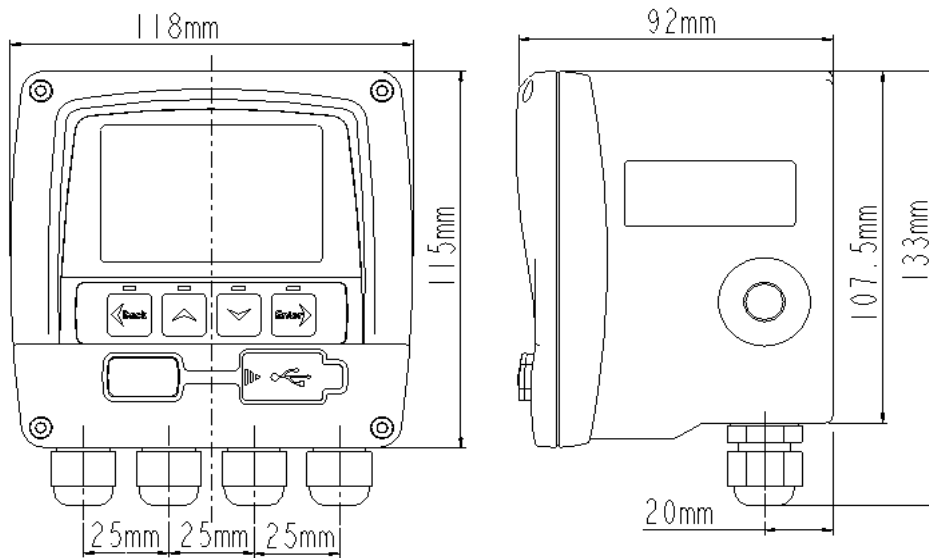

Figure: Wall housing

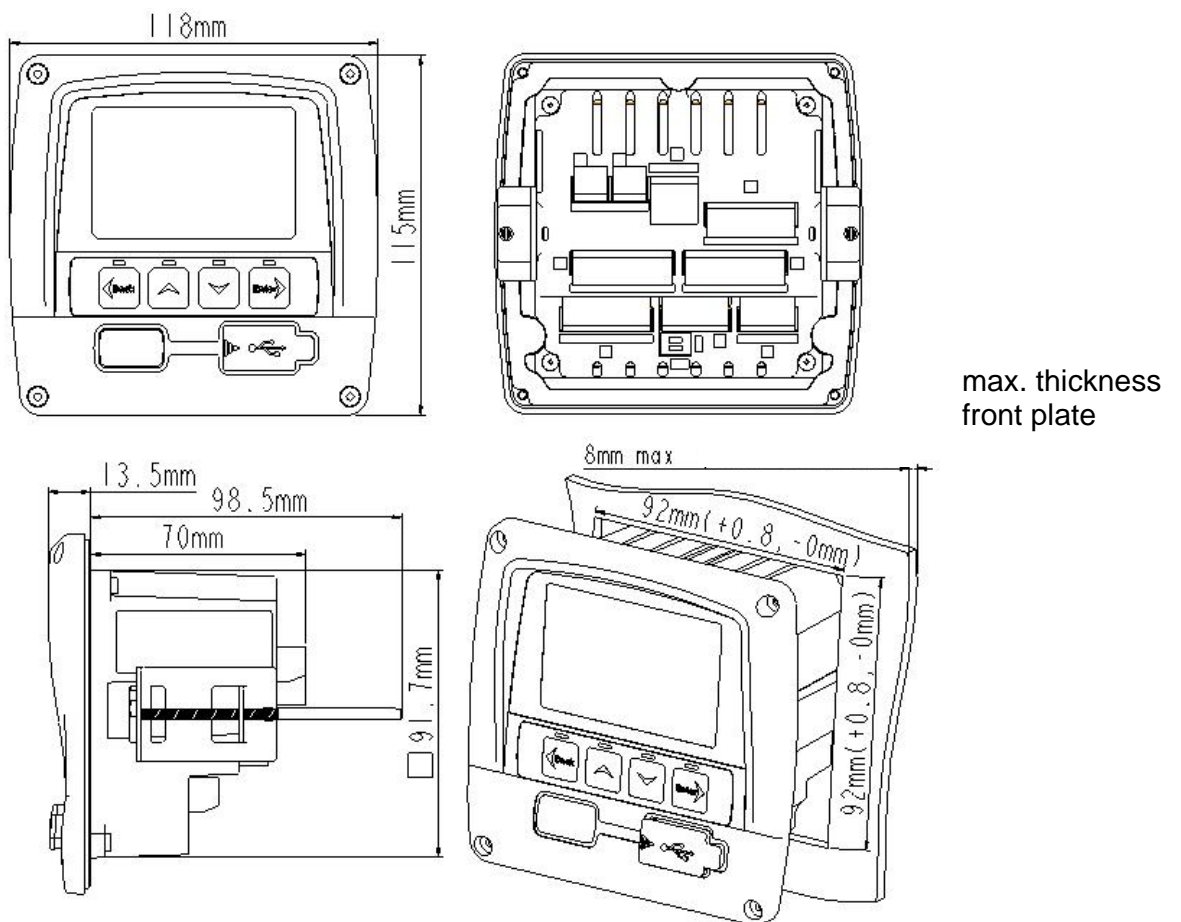

Figure : Housing for panel mounting

11. Connection without RS 485

The following diagram is the terminal block layout at the DS 300 back side without RS 485. / Modbus

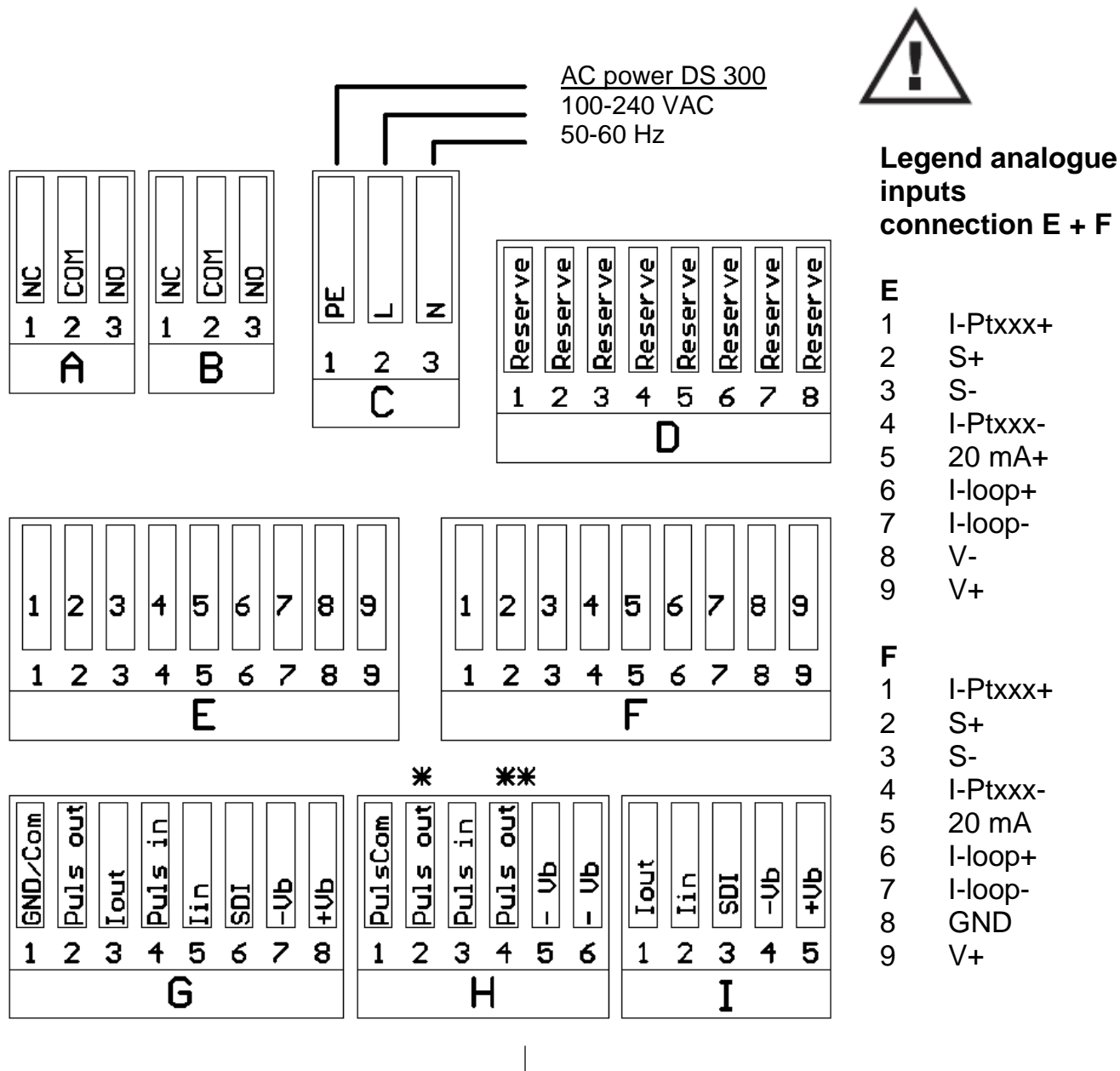

Figure: Terminal block layout at DS300 back side without RS 485 / Modbus

The analogue input module (connections E and F) are optionally available.

Attention:

Please be sure that the sensors are connected according to the wiring diagrams. DS 300 requires a sensor setting. This can either be effected on our premises or by yourselves by means of the DS 300 configuration software.



AC power DS 300
100-240 VAC
50-60 Hz

Power supply alarm connection

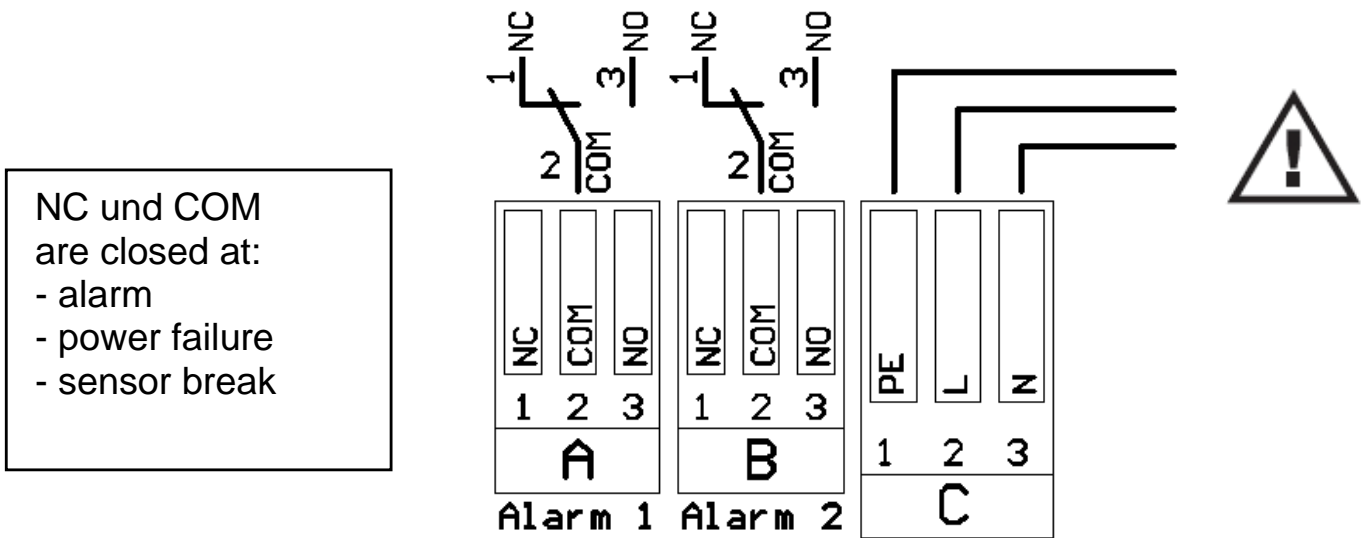

Figure: Terminal blocks for power and alarm

Important note:

All consumption and dew point sensors offer the possibility to provide the measured values as analogue current signal 4...20 mA for further process treatment. The connection schemes have already been set for this. These clamps need not to be connected if the current signal is not used. Exception: In case of FA 300 and FA 415 the wire links have to be inserted if the current signal is not used (factory-provided).



Connection of 2 VA 300 consumption sensors

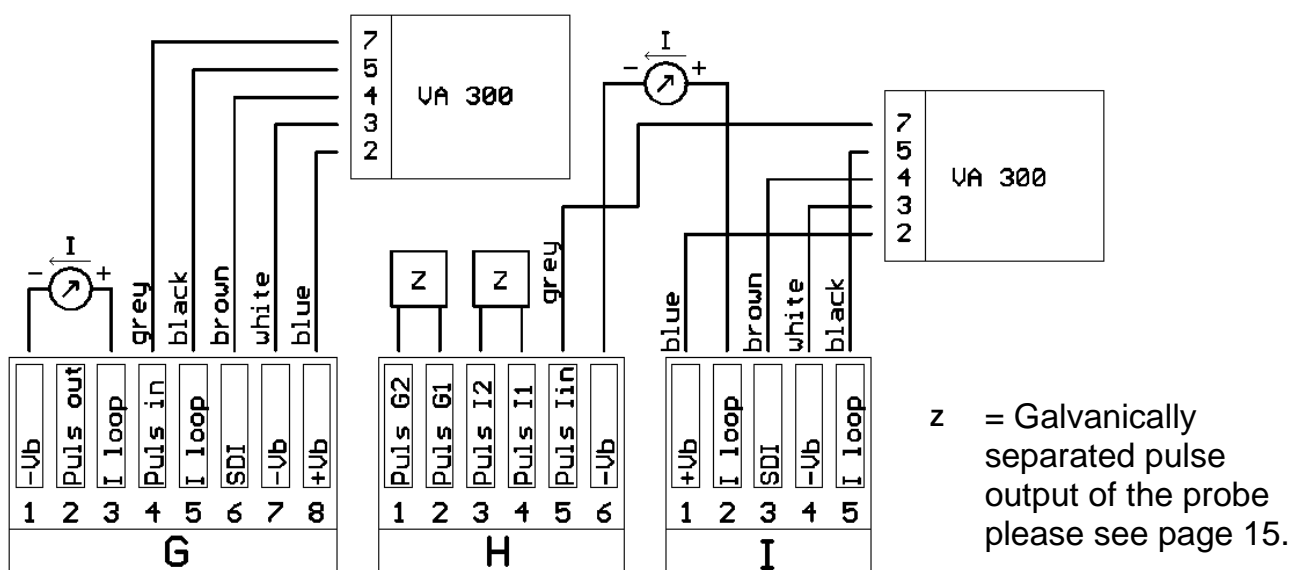
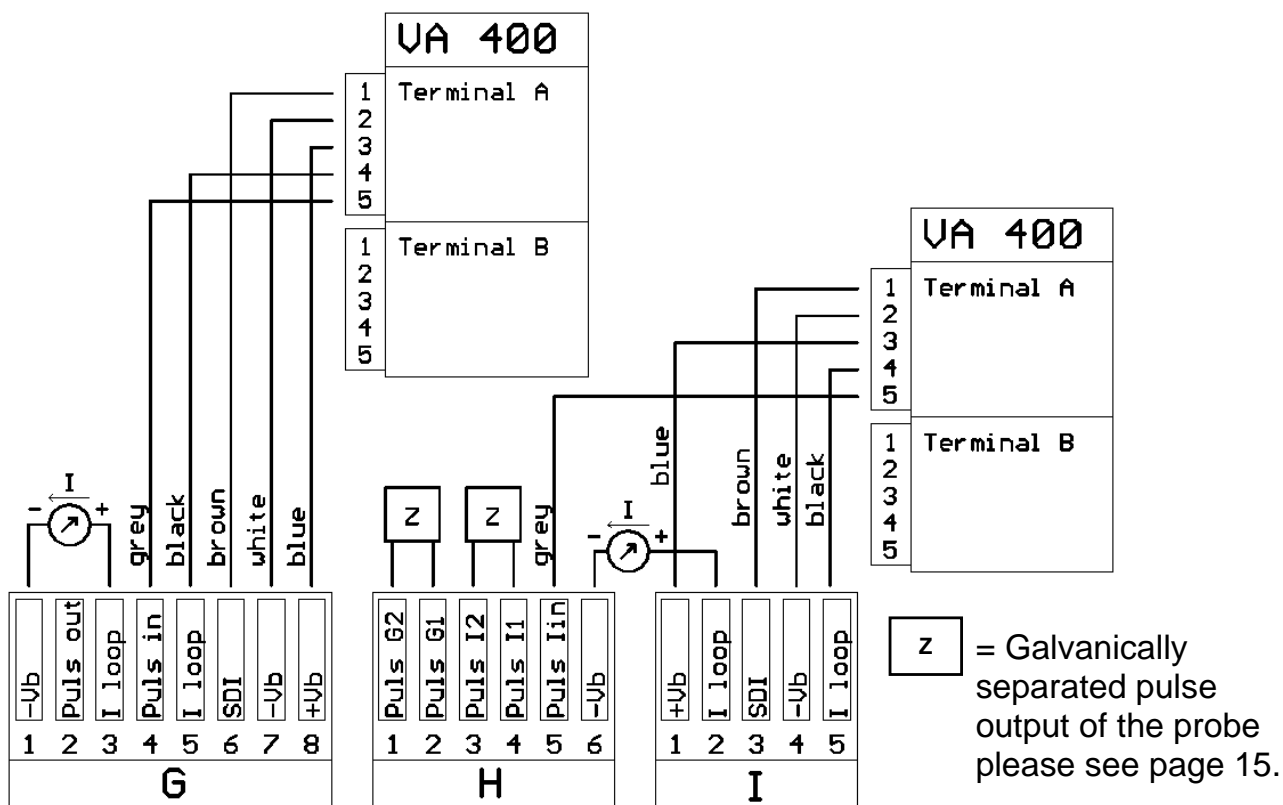
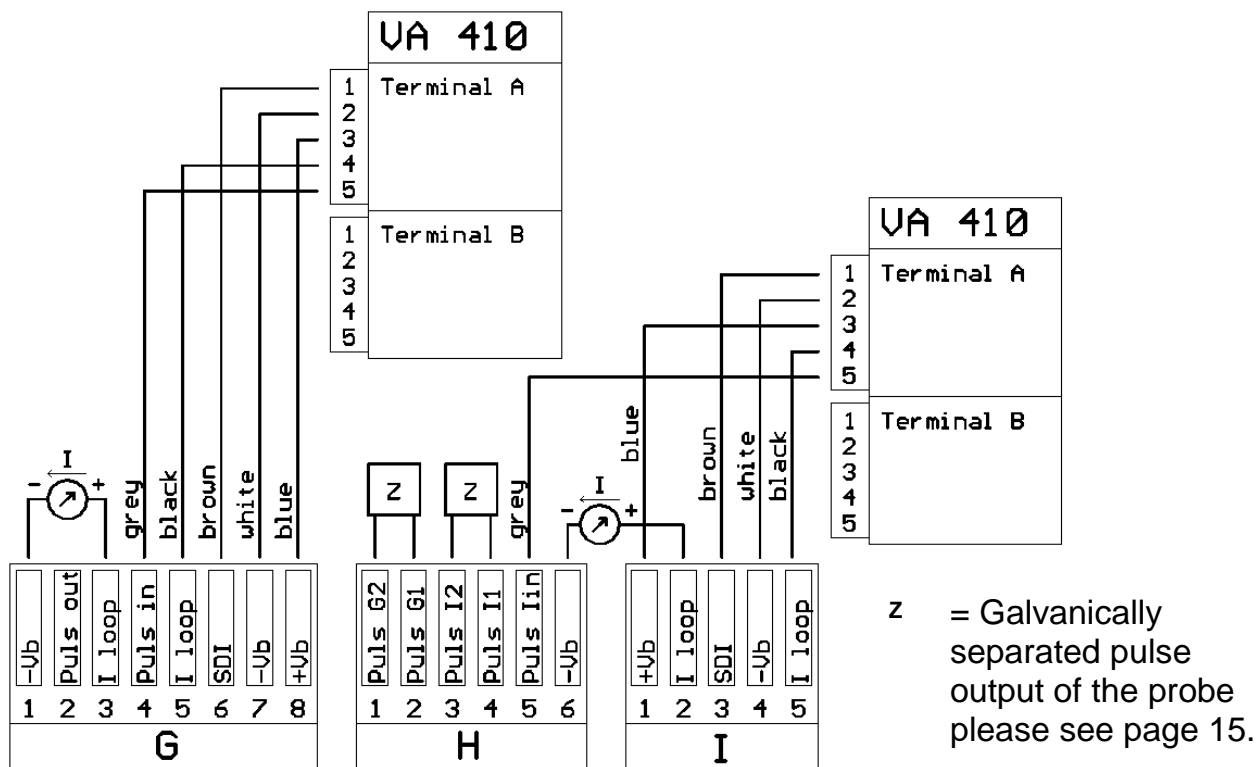

Figure: VA 300 sensor connection

Connection of 2 VA 400 consumption sensors



Connection of 2 VA 410 consumption sensors



Important information:

VA 400/VA 410 sensors can be optionally equipped with an own display which shows the online values. In order to cooperate with DS 300 special settings have to be done in VA 400/VA 410 sensors. These settings are done via the configuration menu of VA 400/VA 410. For more details please take a look at the instruction manual to VA 400/VA 410.



Galvanically separated pulse output

The galvanically separated pulse outputs are available for both flow sensors. It deals with semi-conductor relays which are galvanically separated from the supply voltage of the flow sensors by means of optoelectronic couplers.

Max switching capacity : U_{max} : 32V, I_{max} : 20 mA

Connection possibility please see below.

One pulse is emitted for each consumption unit, for further data please see instruction manual VA 400 or VA 410.

Pulse value: If the consumption unit in DS 300 is set to m^3 one pulse will be emitted for each m^3 used. If the consumption unit in DS 300 is set to liter one pulse will be emitted for each liter used.

Further changes of the pulse value can only be carried out at the sensor via the CS Service Software (SFA).

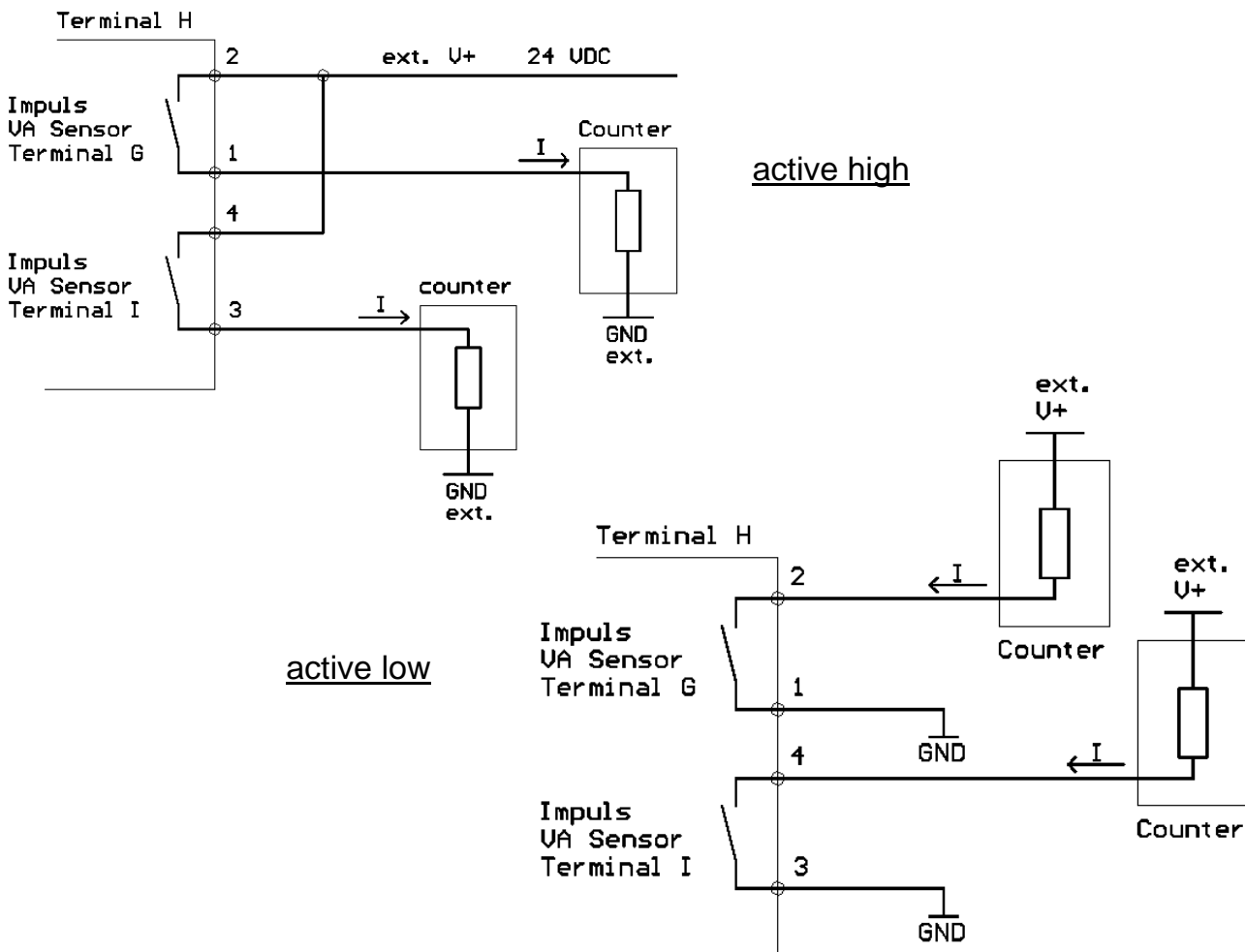

Connection of 2 FA 300 dew point sensors

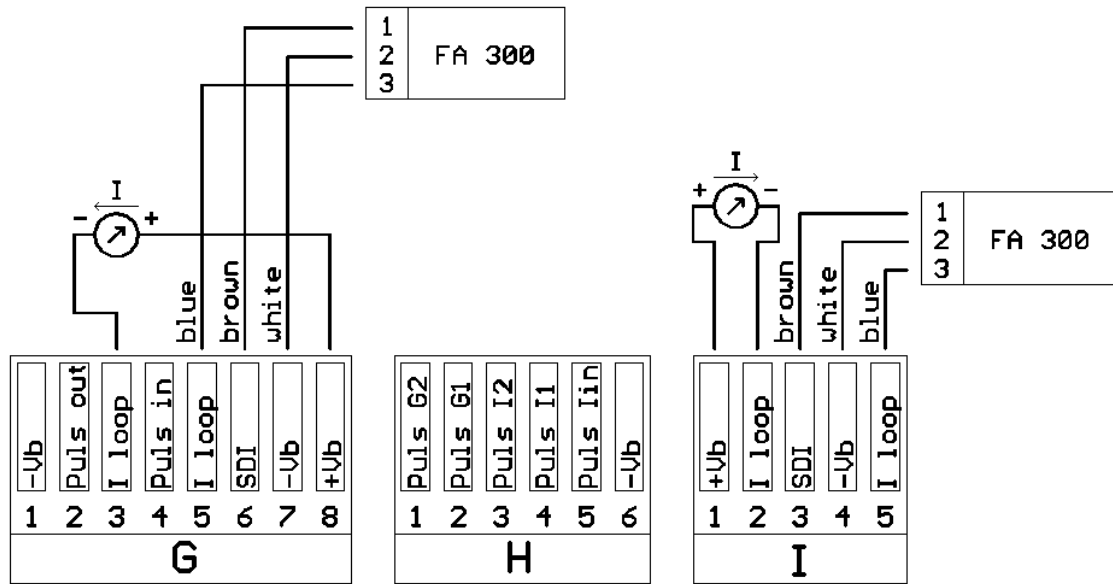

Figure: FA 300 sensor connection

Connection of 2 FA 400 dew point sensors

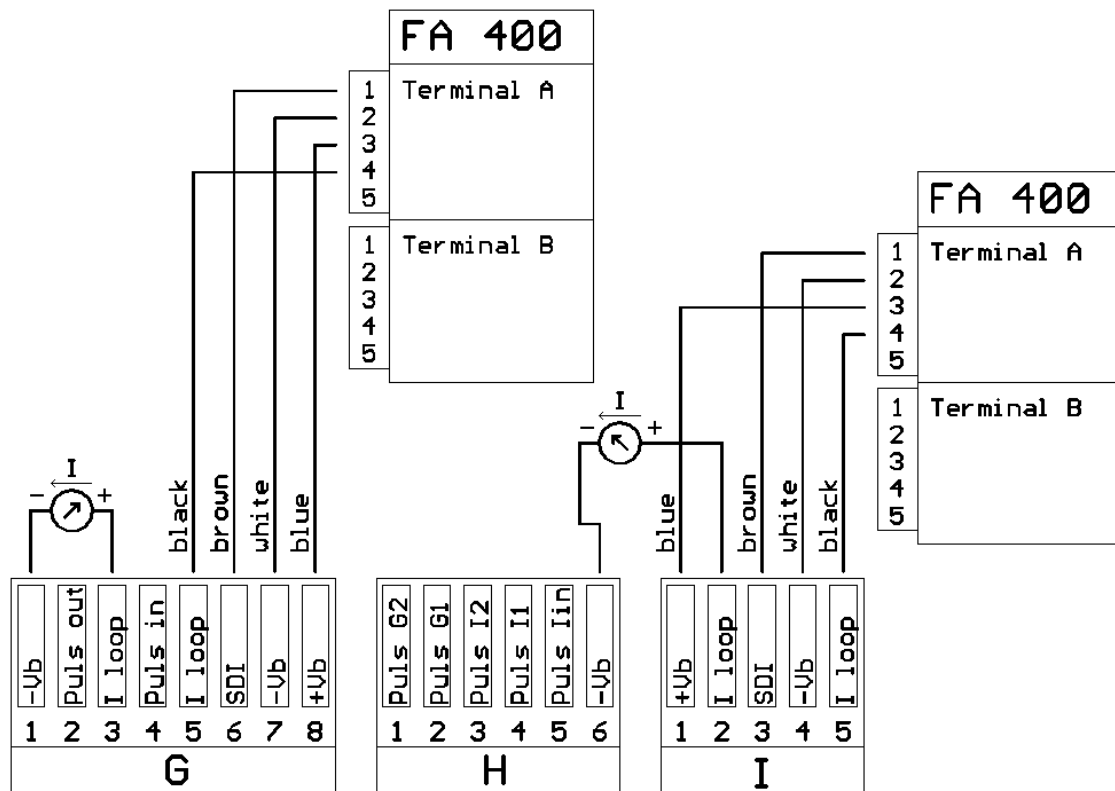

Figure: FA 400 sensor connection

FA 400 sensors have a display which shows the online values. In order to cooperate with DS 300 special settings have to be done FA 400 sensors. These settings are done via the configuration menu of FA 400. For more details please take a look at the instruction manual to FA 400.



Attention:

Please make sure that the sensors are connected according to the above diagram. Please make also sure that the configuration you have ordered and/or done by means of the **DS configuration software** by yourselves is matched to the connected sensors.



Connection of 2 FA 410 dew point sensors

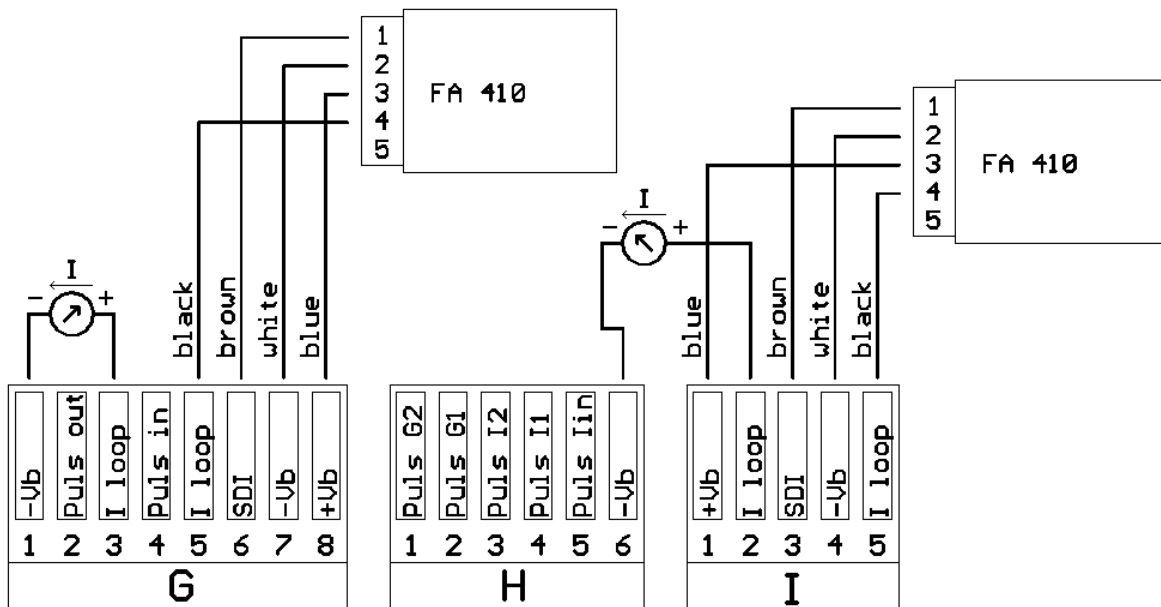

Figure: FA 410 sensor connection

Connection of 2 FA 415 dew point sensors

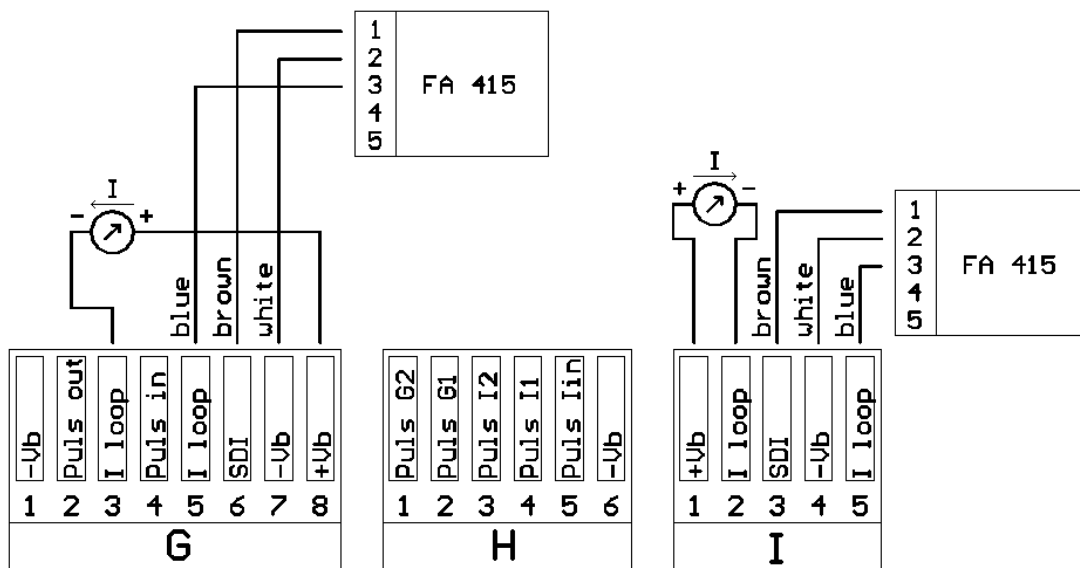
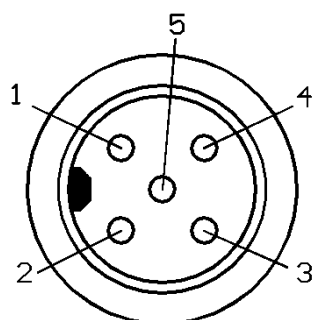
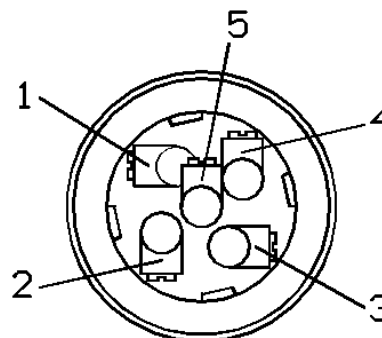

Figure: FA 415 sensor connection

M12 connection plug pinning of all CS sensors (FA 4xx, VA 4xx)



M12 Socket (Sensor)



M12 Plug (Customer)

Connection colours for all CS sensors with cable:

| M12 plug | Cable colour | FA400 | FA410 | FA415 | FA416 | VA400 | VA410 |
|-------------------|--------------|---------|--------|-------|-------|---------|---------|
| Terminal A | | | | | | | |
| 1 | brown | SDI | SDI | SDI | SDI | SDI | SDI |
| 2 | white | V- | V- | V- | V- | V- | V- |
| 3 | blue | V+ | V+ | V+ | V+ | V+ | V+ |
| 4 | black | 4-20mA | 4-20mA | | Relay | 4-20mA | 4-20mA |
| 5 | grey | | | | Relay | Pulse | Pulse |
| Terminal B | | | | | | | |
| 1 | brown | SDI SEL | | | | SDI SEL | SDI SEL |
| 2 | white | | | | | | |
| 3 | blue | | | | | | |
| 4 | black | Relay | | | | | |
| 5 | grey | Relay | | | | | |

Analogue inputs E and F

The probe inputs E and F have identical pin assignments for analogue sensors 0...1/10 V, 0/4...20 mA, thermocouple, Pt100/ Pt1000.

The inputs are configured on our premises. If you want to connect other sensors than those which are set on our premises you can freely adjust the inputs E and F by means of the DS 300 configuration software, order no. 0599 2000.

Thermocouple NiCr-Ni type K for input E and F

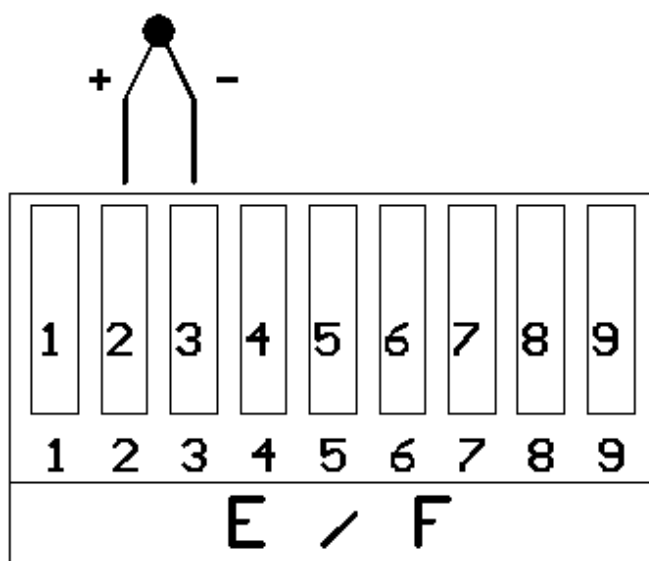

1 /

2 Connection + thermocouple

3 Connection - thermocouple

4 /

5 /

6 /

7 /

8 /

Pt100/Pt1000 connection to E and F

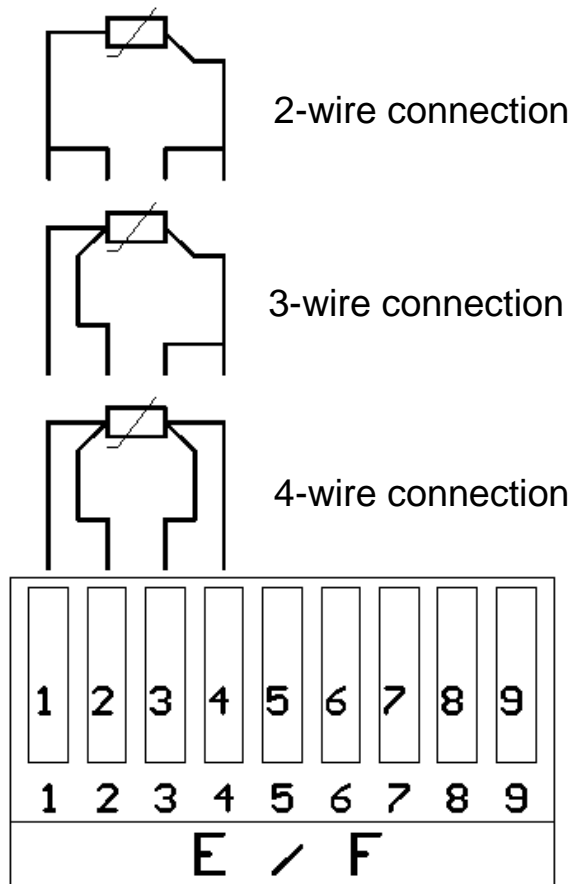

1 I-Ptxxx+ / 3-wire

2 Pt100/Pt1000 +

3 Pt100/Pt1000 -

4 I-Ptxxx

5

6 /

7 /

8 /

Sensors with voltage outputs 0...1/10 VDC with and without voltage supply through DS 300

External voltage supply:

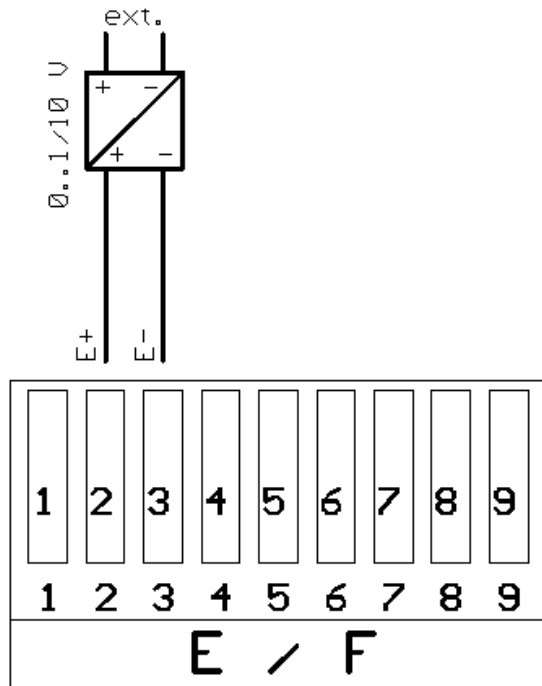

- 1 /
- 2 Signal + (0...1/10 V)
- 3 Signal - (0...1/10 V)
- 4 /
- 5 /
- 6 /
- 7 /
- 8 Voltage supply 0 V
- 9 Voltage supply 24 V DC

With voltage supply through DS 300:

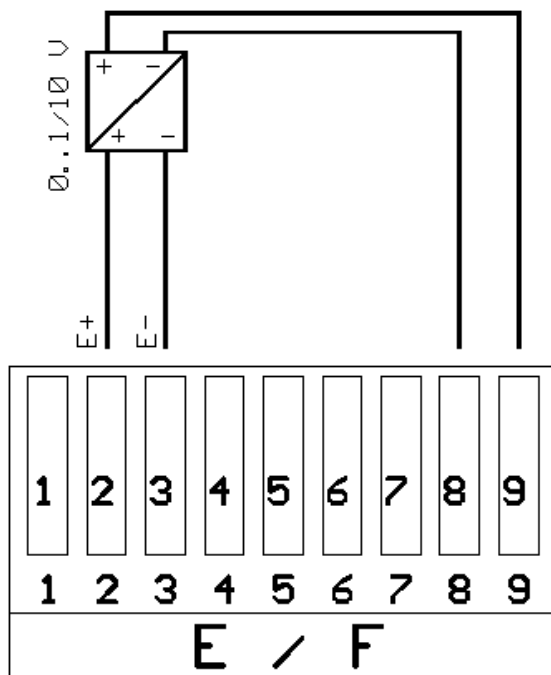

Sensors with current loop in 2-wire technology with internal supply DS 300, e. g. pressure sensors 4...20 mA in 2-wire technology

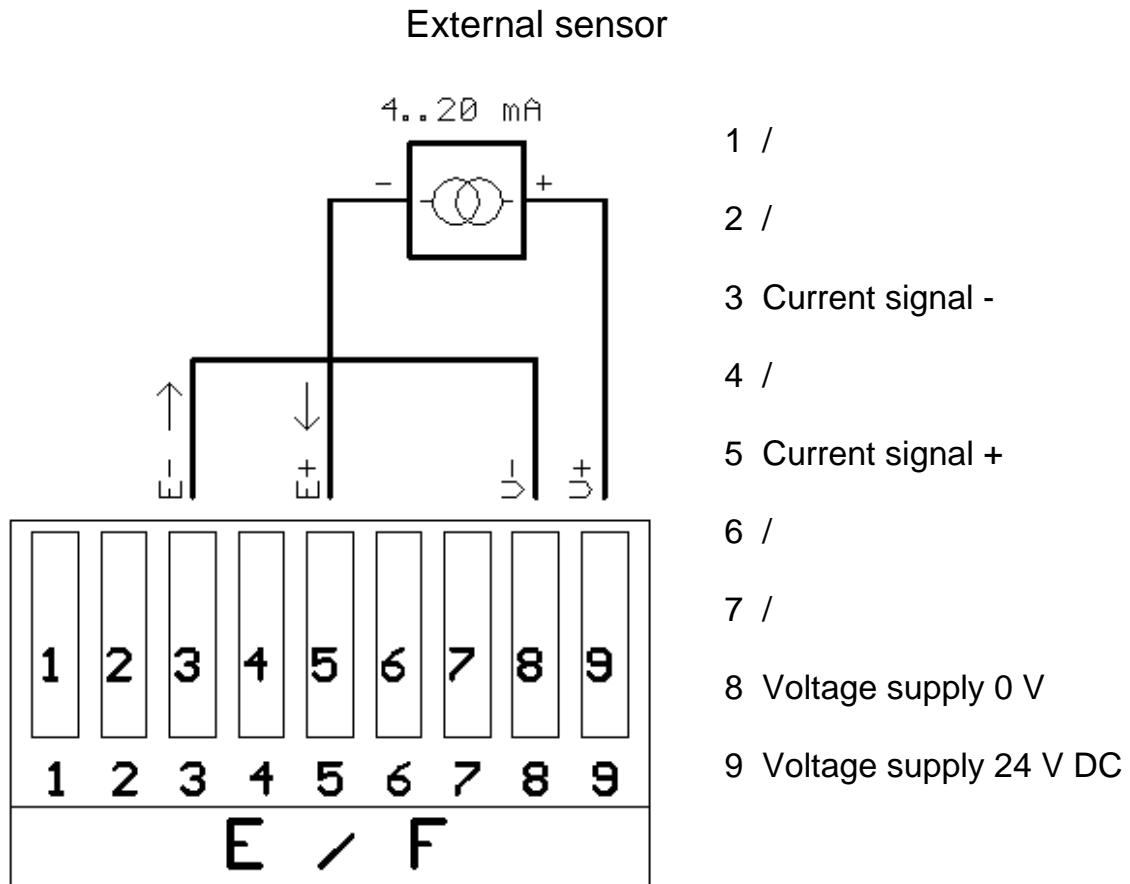

Attention: The scaling for 4...20 mA given by you has already been adjusted on our premises.

Sensors with 0/4...20 mA and external voltage supply

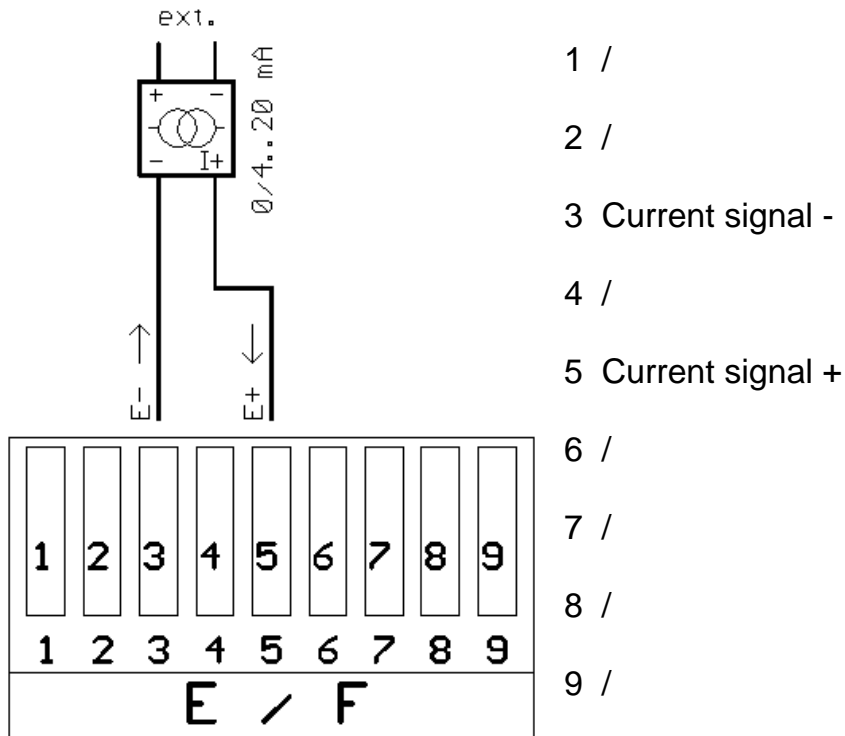

Sensors with current loop 0/4..20 mA and voltage supply through DS 300

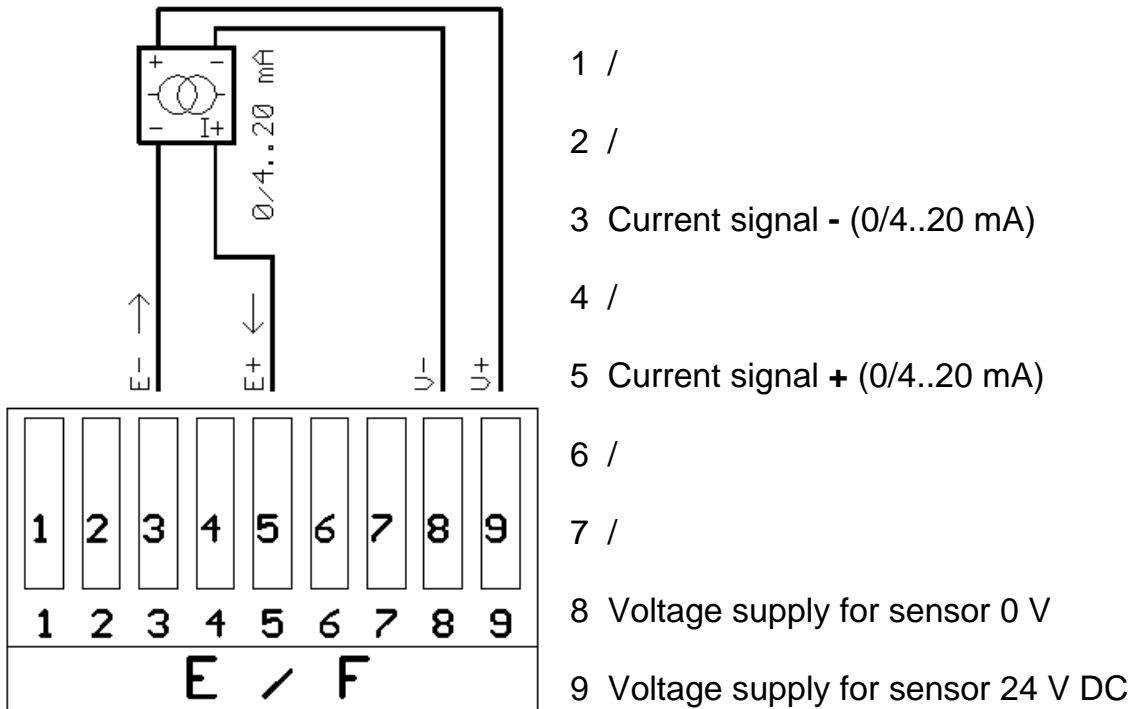

Sensors with 4..20 mA 2-wire technology voltage supply through DS 300 and additional external display

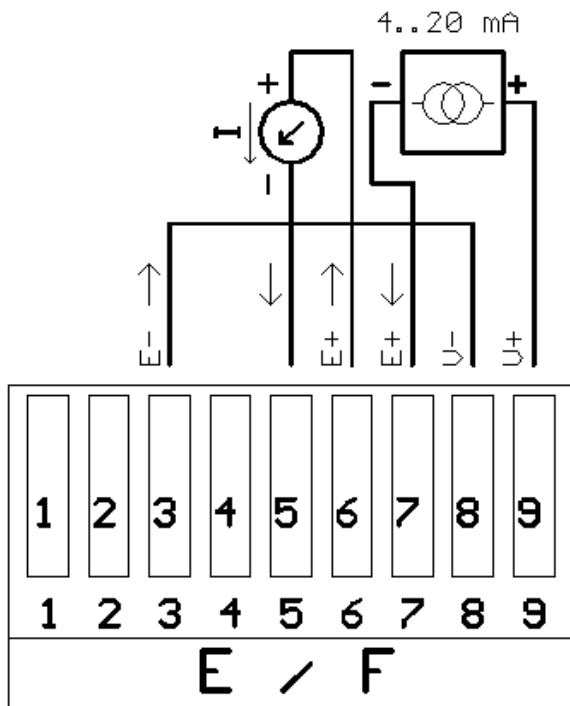

- 1 /
- 2 /
- 3 Current signal -
- 4 /
- 5 Current signal +
- 6 Current signal
- 7 Current signal
- 8 Voltage supply 0 V
- 9 Voltage supply 24 V DC

Sensors with 0/4..20 mA signal, external voltage supply and additional external display

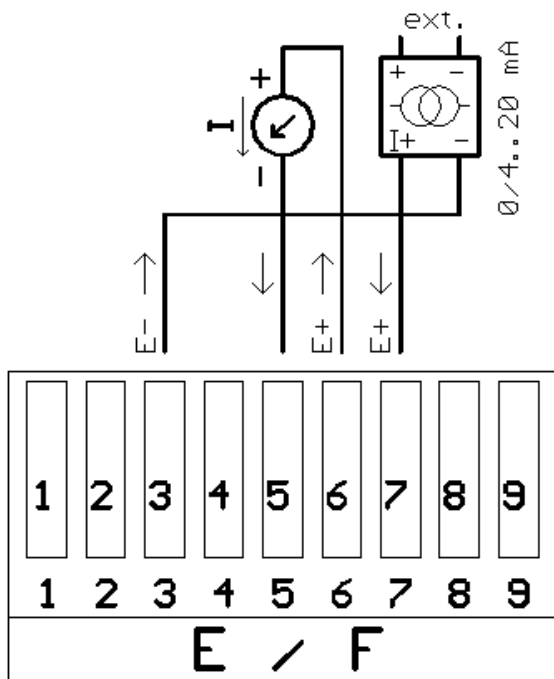

- 1 /
- 2 /
- 3 Current signal -
- 4 /
- 5 Current signal +
- 6 Current signal
- 7 Current signal
- 8 /
- 9 /

Sensors with 0/4..20 mA signal and voltage supply through DS 300 and additional external display

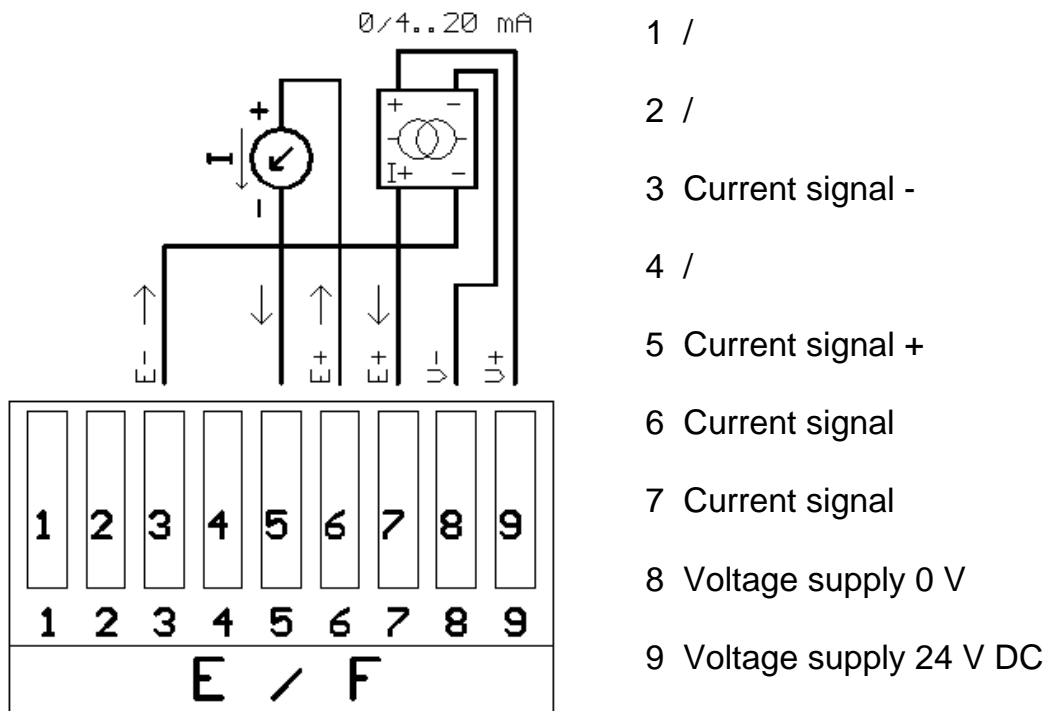

Attention:



DS 300 requires a sensor setting. This can either be effected on our premises or by yourselves by means of the DS configuration software.

DS 300 Configurationsoftware incl. USB-cable (Order no.: 0599 2000)

12. Connection with RS 485

The following diagram is the terminal block layout at the DS 300 back side with RS 485

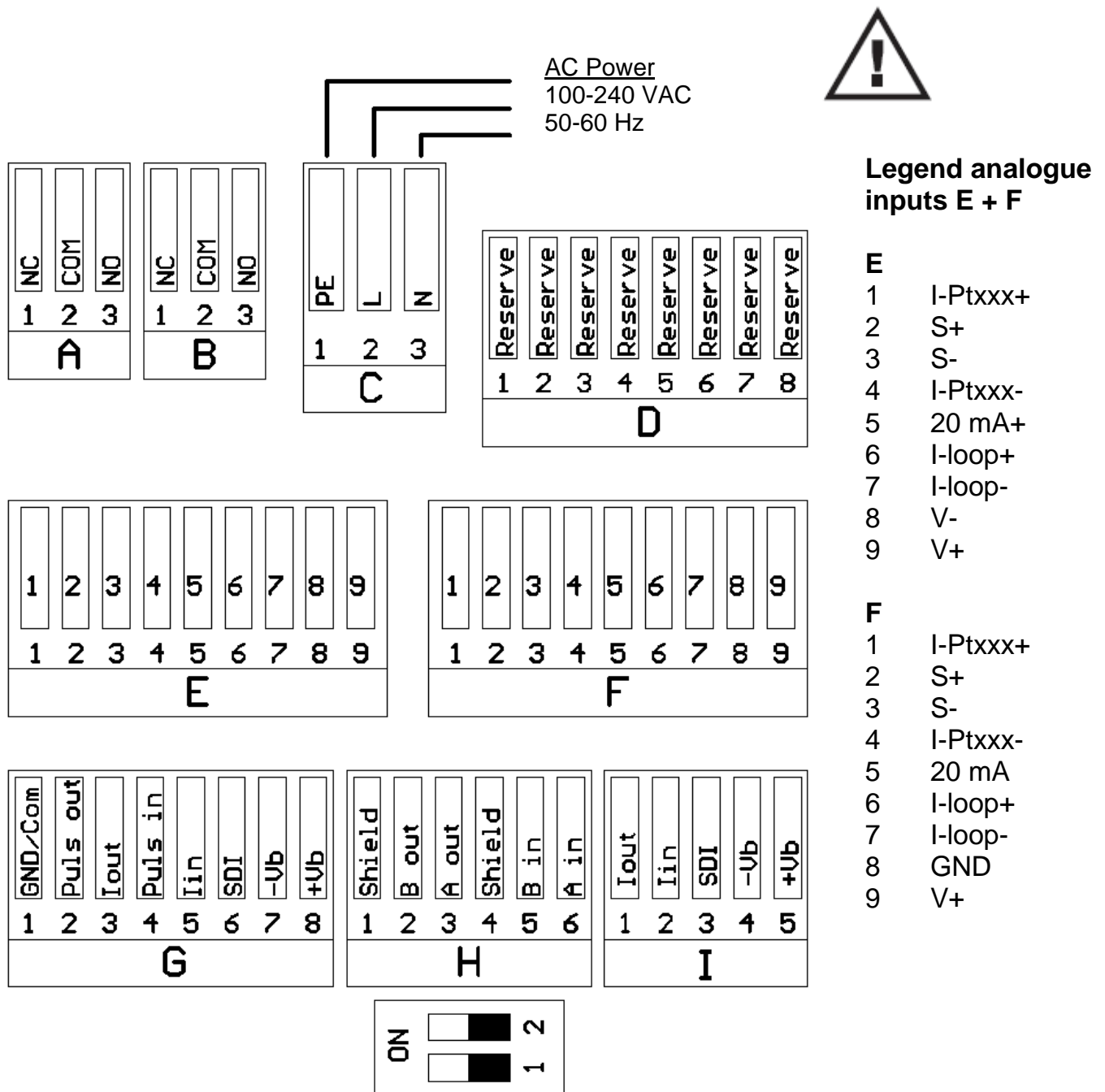

Figure: Terminal block layout at DS300 back side with RS 485

The analogue inputs (connections E and F) are optionally available.

RS 485 network connection

For establishing a Bus connection with RS 485 please do the following connections:

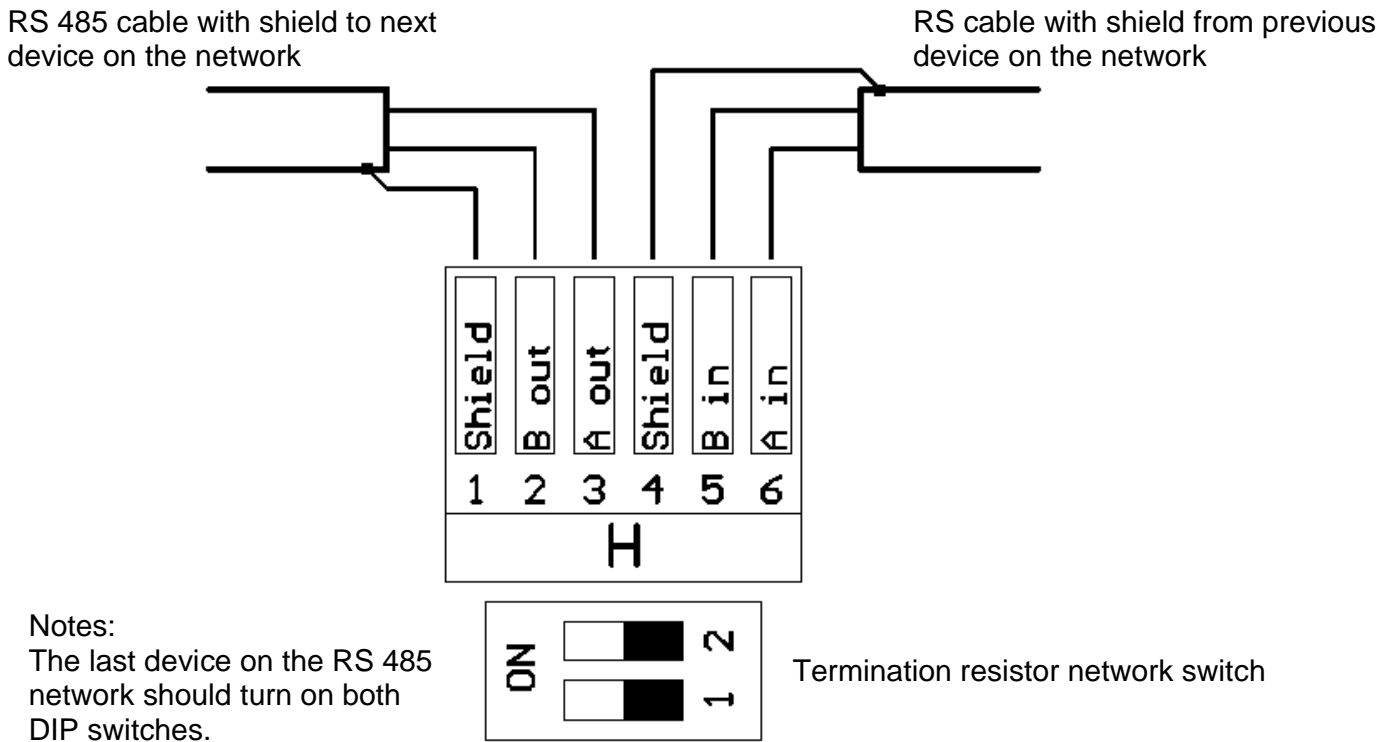

Figure: RS 485 network connection

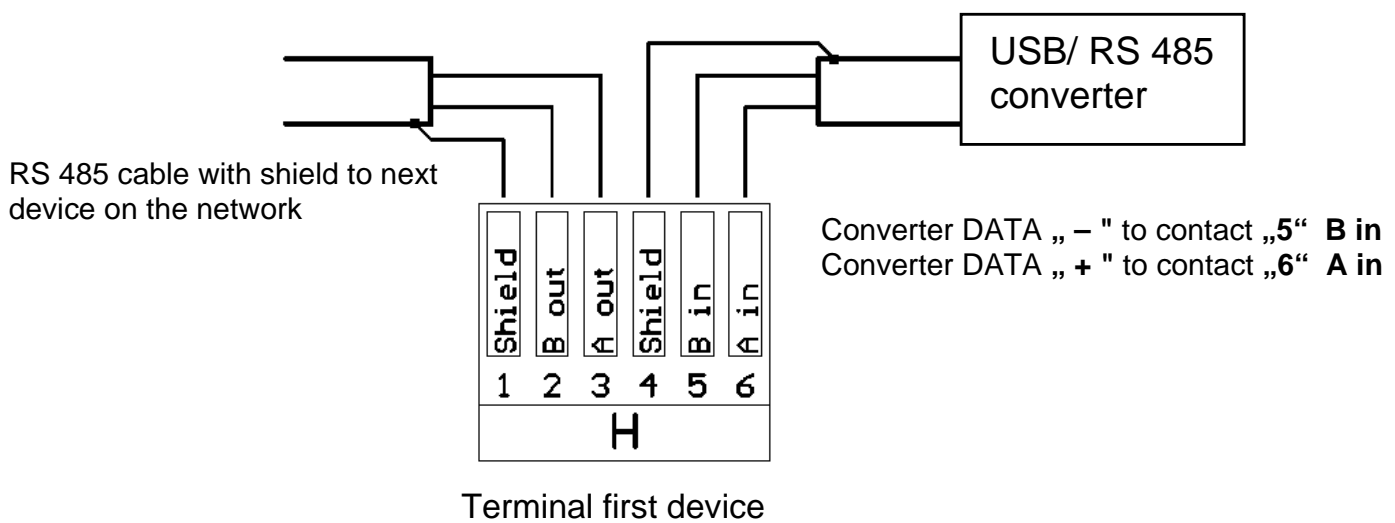

Figure: Converter connection

Bus system RS 485 network

Only cables according to the recommendations of EIA 485 standard should be used. A maximum of 32 devices may be connected to one segment. The bus cable must be laid at a distance of at least 20 cm from other cables. It should be laid in a separate, conductive and earthed cable trunking. It must be ensured that no potential differences occur between the individual devices on the bus.

| | | |
|-----------------------------|------------------|--|
| Cable specification: | Impedance: | 135 - 165 Ohm @ 3 to 20 Mhz |
| | Cable capacity: | < 30 pF/m |
| | Cable diameter.: | > 0,64 mm |
| | Cross section: | > 0,34 mm ² /AWG 22 |
| | Loop resistance: | < 110 Ohm/km |
| | Screening: | Cu shielding braid or shielding braid and shielding foil |

Connection scheme

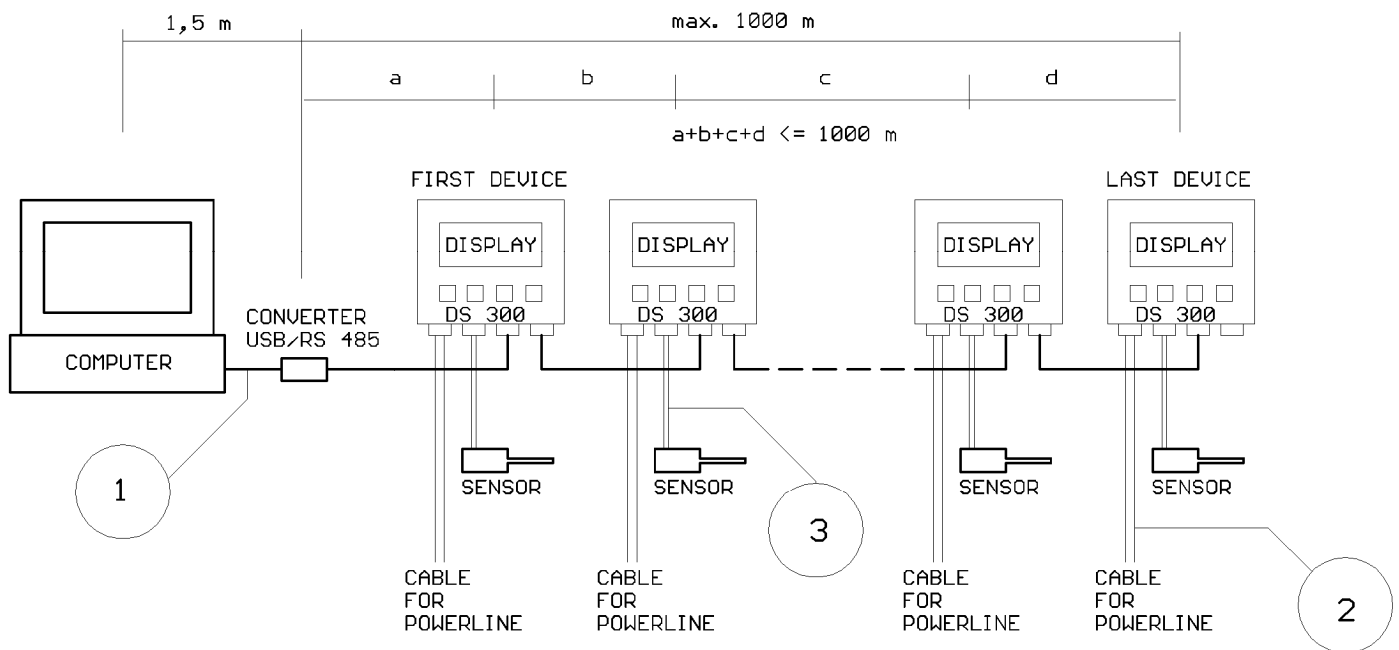

- 1 - Cable between Computer and Converter = purchased parts package
- 2 - Cable for Powerline = purchased parts package 1,8 m with connector if you need more length use a cable 3 x AWG18 or 17, 300V AC
- 3 - Cable between DS300 and sensor = purchased parts package = 5 m

Connection of 2 VA 300 consumption sensors

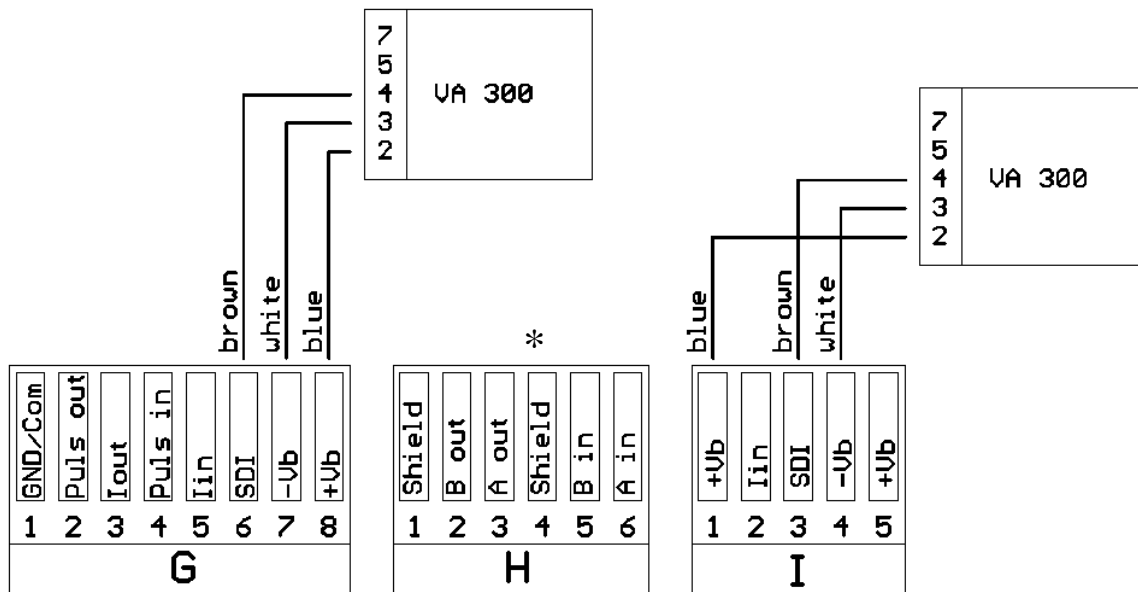

Figure: VA 300 sensor connection with RS 485

Connection of 2 VA 400 consumption sensors

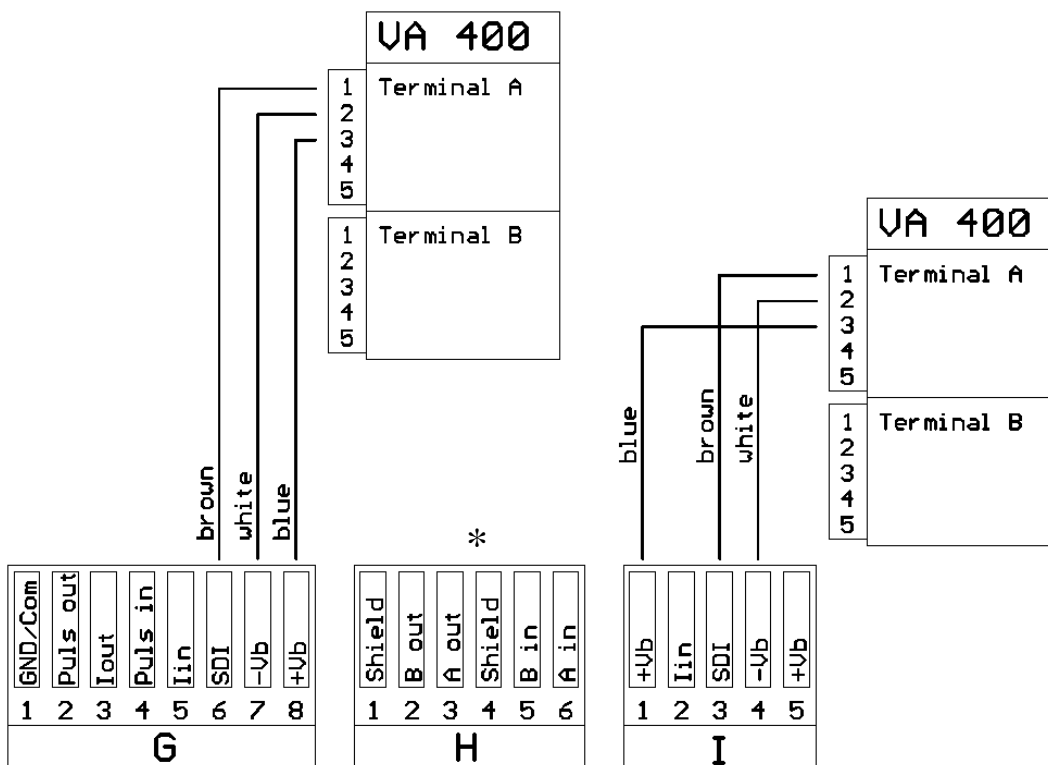

Figure: VA 400 sensor connection with RS 485

* Connection terminal H see page 27

Connection of 2 VA 410 consumption sensors

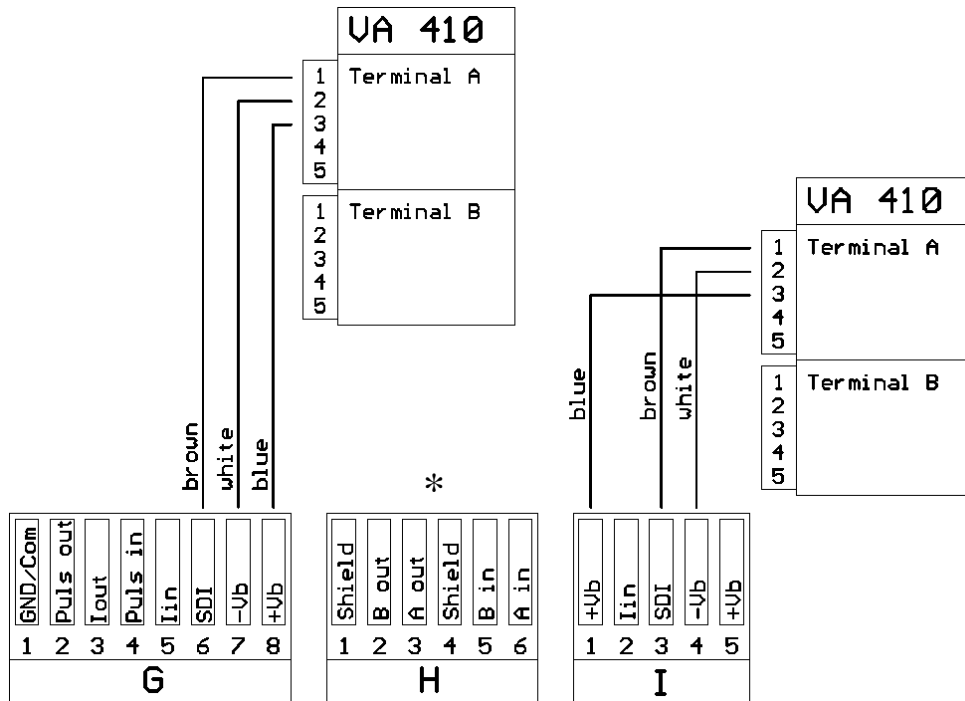

Figure: VA 410 sensor connection with RS 485

Connection of 2 FA 300 dew point sensors

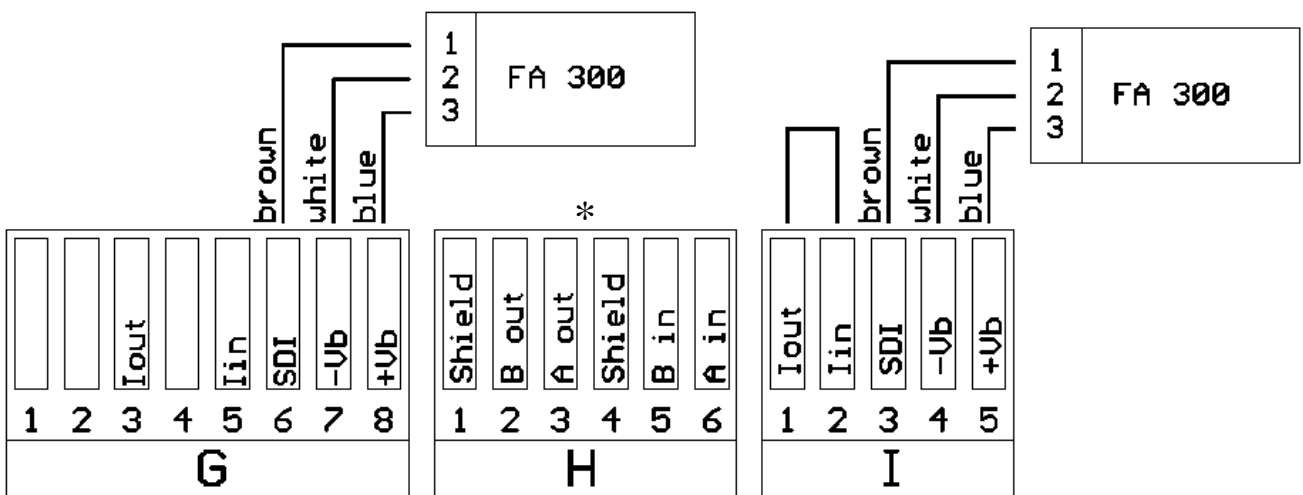

Figure: FA 300 sensor connection with RS 485

* Connection terminal H see page 27

Connection of 2 FA 400 dew point sensors

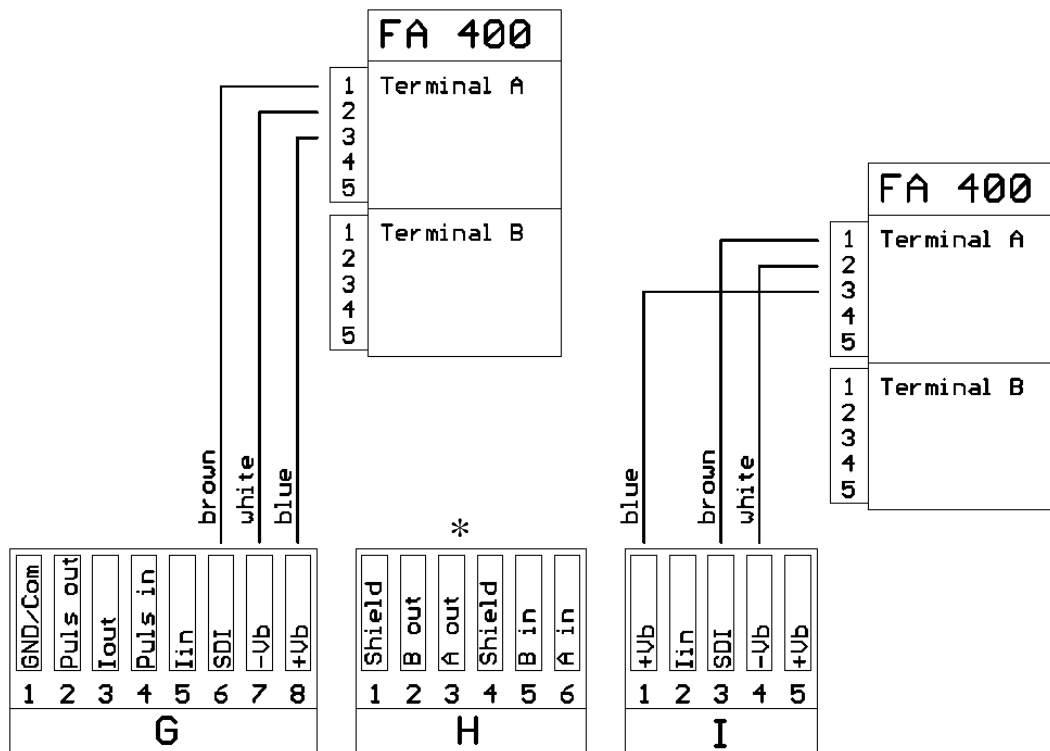

Figure: FA 400 sensor connection with RS 485

Connection of 2 FA 410 dew point sensors

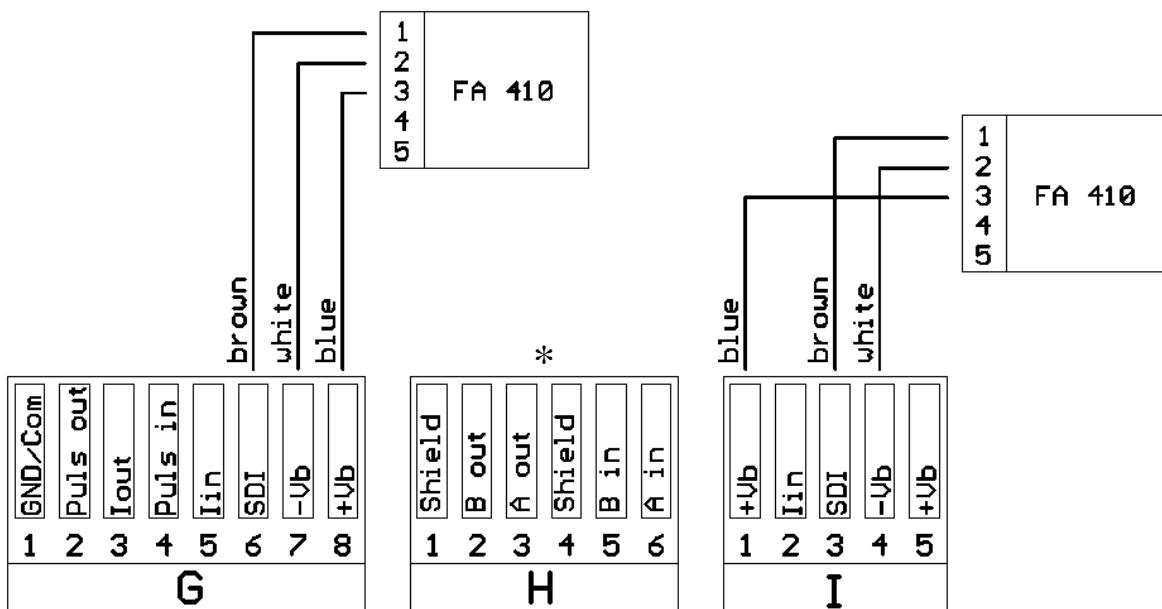

Figure: FA 410 sensor connection with RS 485

* Connection terminal H see page 27

Connection of 2 FA 415 dew point sensors

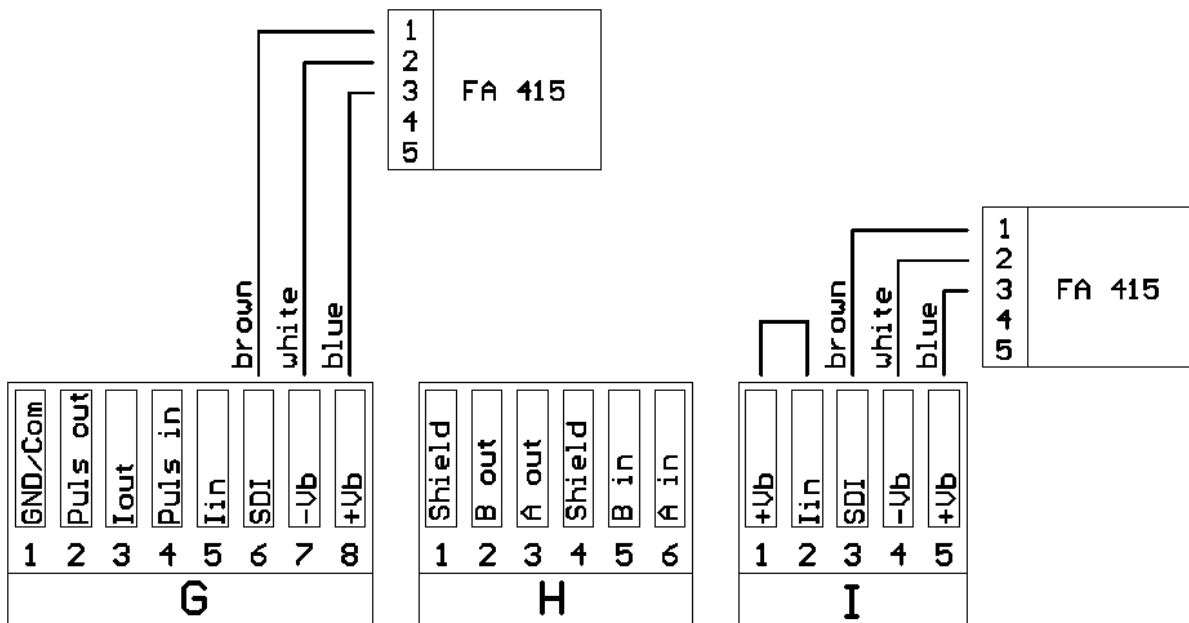

Figure: FA 415 sensor connection with RS 485

* Connection terminal H see page 27

13. Connection with option Ethernet interface

DS 300 is connected via a standard EtherNet RJ45 plug.

For panel mounting or as a wall housing DS 300 can be connected directly by means of the Ethernet RJ45 plug (wall housing IP65).



Internal RJ45 interface



External RJ45 interface (IP65)



Insert EtherNet RJ45 cable into the plug, then attach the tension relief

13.1 Protocol selection in DS 300

DS 300 supports different protocols - CS-Bus or MODBUS - which can be selected via the instruction menu in DS 300. CS Soft Professional and CS Soft Professional RS 485 work with the CS Bus protocol (standard works calibration).

The MODBUS protocol can be used for integration into customer-owned systems.

In this case please request the protocol description of the MODBUS at CS Instruments GmbH.

In order to change the protocol if necessary please proceed as follows:

1. Press [Enter] in the while showing actual values in order to access the **main menu**
2. Choose "**Communication setting**" by means of the ▲▼ keys and confirm with [Enter]
3. Select "**Select protocol**" and confirm with [Enter]
4. Select "**CS-BUS protocol**" and confirm with [Enter]
5. By means of pressing the [Back] key several times you get back to the actual measuring values

14. Operation

Description of the display symbols

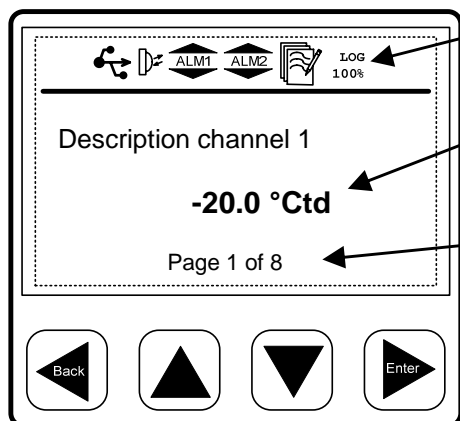

Status display, please see below for detail description of different status icons.

Only one page of measurement value will be shown at a time. The user can use ▲ or ▼ key to scroll through all available values.

Page view indication:

This "page view indication" shows the current page no. of the displayed measurement values and the total no. of pages

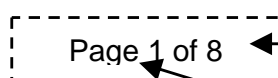

Indicates there are in total 6 pages with measurement values available

Indicates that page 1 of in total 8 pages with measurement values is displayed

Status icon detail description:

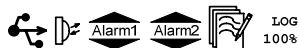

Status icon shows different status of the system. In the following please find the explanation of every single symbol:



1) USB connection icon: icon shows when DS 300 is connected to PC via USB

2) Alarm 1 status icon:



2.1) Alarm 1 is set and upper limit is reached



2.2) Alarm 1 is set and lower limit is reached



3) Alarm 2 status icon: indication like Alarm 1 icon



LOG 100% 4) Logger module status icon

Logger module status:

WAIT: Time start condition set and waits for start logging

LOG: Logger module is doing data logging

STOP: Logging is stopped

DEL: Logger is deleting protocol data

ERR: Error occurred during data logging

Logger module free memory in percentage or CYCLE when logger memory in circular mode

14.1 Basic key operation

Basic concept for MENU mode key operation:

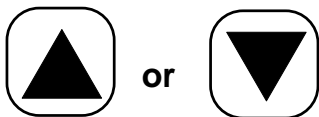
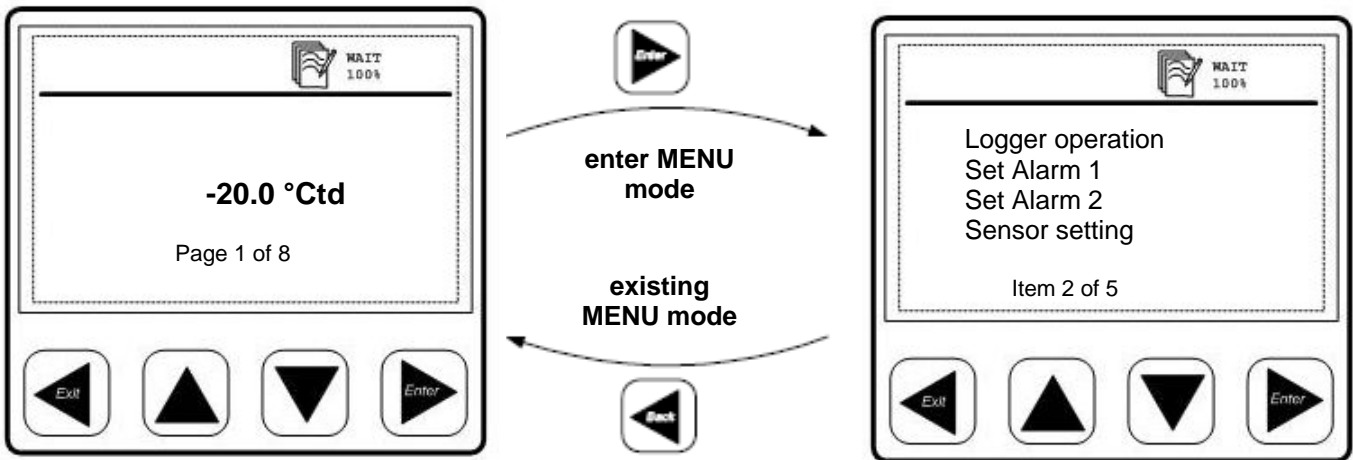

- use these keys to browse and select different items in the menu and scroll through different pages of measurement values display
- use these keys to alter or adjust the setting option or numbering



- use this key to exit the current menu level
- use it to leave all setting state without saving the change



- use this key to enter the submenu or next menu level of the currently selected menu item
- use it to confirm the setting change or enable an option in all setting state

Typical menu display layout and keys description:

The currently selected menu item will be shown in negative colour.

If there is a "<" sign it means we can exit the current menu or go to the next higher level from the current menu level.

If there is a ">" sign it means we can go into the submenu of the currently selected menu.



Selectable menu item, it shows 4 items at a time. If the total items in the current menu level is more than 4 items the menu item should scroll over.

It tells how many items exist in the current menu and which no. of items is currently selected.

Typical display layout for option selection:

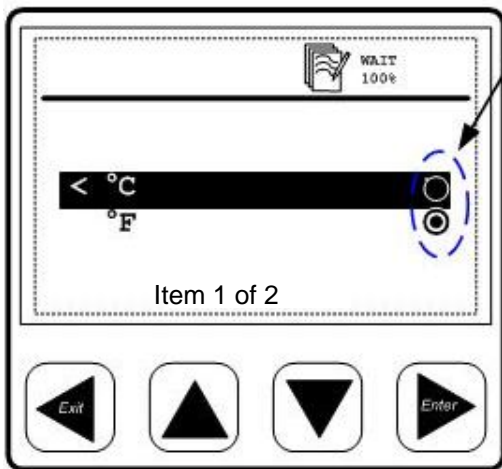

The radio button for selecting the units (°C/°F)

- - Radio button style for de-selected item
- - Radio button style for selected item

Procedure:

- 1) Use ▲ or ▼ key in order to select the desired option
- 2) Use ► key to activate the selected option

For leaving this option:

- 1) Use the ◀ key to go back to the last menu level without activating the selected option

Typical display layout for altering or adjusting the number setting:

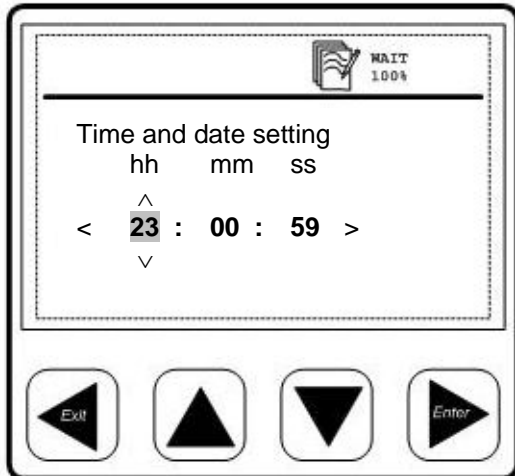

Example: Time and date setting

- 1) Use ▲ and ▼ key to adjust the time
- 2) Use ► key to move from HOUR to MINUTE to SECOND
- 3) After the SECOND setting press the ► key to finalize and store the setup or press ◀ to exit from the "Time and date setting" menu and without saving the new setting

Powered on device

If DS 300 mobile version is powered on the display will show the following system information for approximately 5 seconds:

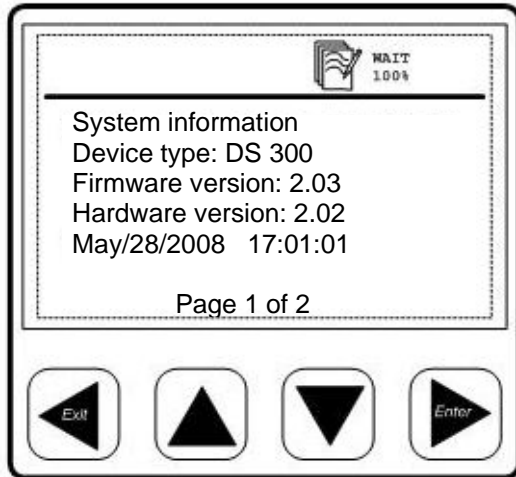

The system information is helpful for any service inquiries in order to identify the specific model and version.

This information can be called up in the menu point "system info" at any time.

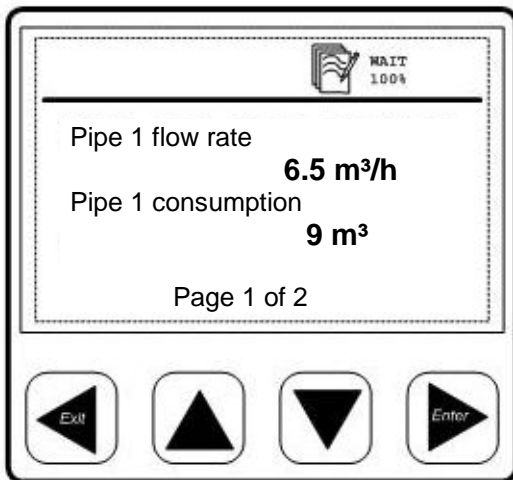

If there are any sensors connected in accordance with the DS 300 configuration, DS 300 will connect to them automatically and start to display real time measurement values acquired from those sensors. The measurement values may be displayed on more than one page. To see another page, just press the

 or  key.

14.2 The operation in detail

DS 300 is supplied with specific customer settings according to the order.

In order to simplify the user interface not all settings are accessible via the user interface. By means of the **DS 300 configuration software** (including USB interface), order no. 0599 2000, additional settings can be changed.

In order to change the additional settings DS 300 can be connected to the PC via the USB interface. For this purpose no power supply is required. After starting the **DS 300 configuration software** the additional device settings are accessible. The following settings are possible:

Settings for analogue sensors such as pressure probes, clamp-on ammeters, temperature sensors and so on have to be done via the **DS 300 configuration software**. This software provides the following settings:

- Selection of the sensors and at which terminal they are connected to
- Settings of the analogue sensors like e. g. the pressure sensor, the clamp-on ammeter, the temperature sensors and so on
- Individual sensor settings: Designation/description of the measuring channels of the CS consumption sensors and the CS dew point sensors
- Alarm settings: Activate/deactivate alarm, allocate measuring channel, allocate direction (alarm in case of exceeding or uncutting the threshold value), fix hysteresis
- DS 300 display can be configured regarding which measuring channel appears in which size and on which page on the display
- User interface functions can be blocked for unauthorized users
- Logger settings: Channels to be recorded, recording interval, start/stop conditions

All settings are stored permanently inside DS 300 and are not necessary to be entered again, unless the user wants to do some changes.

Main menu DS 300 mobile version:

- Logger operation
- Set Alarm 1 (not active in case of DS 300 mobile version)
- Set Alarm 2 (not active in case of DS 300 mobile version)
- Sensor setting
- Communication setting (only active in case of version with RS485/Modbus)
- System status and setting

14.2.1 Logger operation

DS 300 includes a data logger (optional). In order to configurate the logger function and to activate/deactivate it, there are several functions available:

| | |
|-------------------------|--|
| Measuring rate | <p>Set logging rate and averaging option The logging rate defines the interval data should be recorded in the memory. It will record from every activated channel a sample. The averaging option can be used to calculate an average value. I.e. DS 300 is measuring every 1 second and if the logging rate is 10 seconds, it will calculate an average value out of the last 10 measurement values and store it as a recorded sample.</p> |
| Manual start | <p>Start/stop logging Starts or stops the data recording. Whenever a new recording is started a new file is created in the memory.</p> |
| Logger status | <p>Shows memory Informs about the memory available and status.</p> |
| Time start | <p>Set time, start conditions DS 300 can be programmed to start at a certain time.</p> |
| Show protocols | <p>Single protocols (files) can be deleted or the whole memory can be freed. DS 300 will show the available protocols with date, number of channels and number of recorded values per channel.</p> |
| Delete protocols | <p>Deletes the selected protocol</p> |

Further features like channels to be logged, memory type (circular or linear) etc need to be configurated via the configuration software.

14.2.2 Alarm settings

There are 2 alarm threshold values ("**Set Alarm 1 threshold**", "**Set Alarm 2 threshold**") which can be set individually.

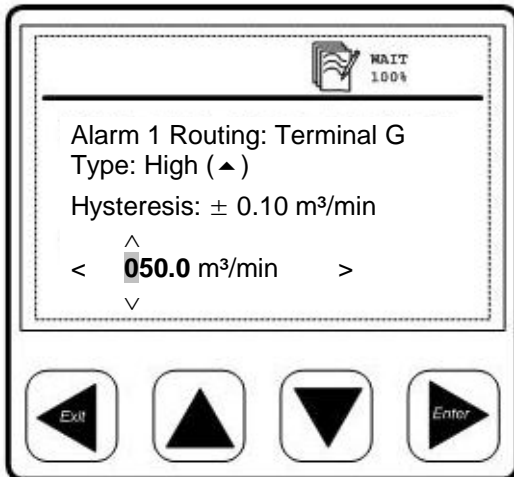

In this example the alarm is routed to Terminal G and is of type High, which means: alarm is triggered when higher than the threshold. If the alarm is exceeded or dropped below the background becomes red resp. starts blinking. The adjustment can be done by means of the DS 300 configuration. Hysteresis is set to 0.10 m³/min.

Please note that routing, type and hysteresis cannot be changed on DS 300. It can be changed by the configuration software.

13.2.3 Sensor settings

Sensor settings for CS flow or dew point sensors are stored within the sensor itself. DS 300 can be used to change those settings. For that purpose select in the menu the function "**Sensor settings**". On the next screen the available inputs are shown: for example: Terminal G: Consumption sensor. Select the desired input to enter into the detailed setting menu;

If a sensor is connected to a switched on DS 300 the settings, stored in the sensor will be transferred to DS 300 (e. g. analogue output, diameter for VA probes, ...) On delivery of a unit DS 300/sensor the adjustments are matched. Please check the coordination if you connect sensors with deviant adjustments to DS 300.



DS 300 Configurationsoftware incl. USB-cable (Order-no.: 0599 2000)

VA 400/VA 300 consumption sensors settings (Attention: Adjust inner diameter!)



For CS consumption sensors following settings can be made:

- **Set inner diameter:** For calculation of volume flow, consumption and flow
- **Set total consumption counter:** Counter can be re-set to zero or set to any other value
- **Enter volume flow unit:** Selection of the desired flow unit
- **Adjust consumption unit:** The consumption unit is fixed by selection of the volume flow unit
- **Adjust measuring unit:** Selection between flow and volume flow.
Select vlow or consumption as analogue output
- **Adjust reference pressure:** In order to calculate the standard volume flow *
- **Adjust reference temperature:** In order to calculate the standard volume flow *
- **Scaling of the analogue output:** If the volume flow unit or the inner pipe diameter are changed we recommend to adapt the scaling of the analogue output. DS 300 will propose a standard scaling. The scaling is used in order to express the volume flow by a 4...20 mA signal which may then be transferred to a BMS (building management system)
- **Adjust gas type:** Adjust the gas type in which the measurement should be carried out

* Please observe:

The reference pressure and the reference temperature are not referred to the current process pressure or process temperature. They are used in order to calculate the standard volume flow in case of standard conditions, e. g. 1000 hPa, 20 °C.



Changes of the sensor settings in DS 300 are immediately stored in the sensor as soon as they are confirmed with <Enter>.



Dew point sensor settings

In this menu the dew point unit can be selected. Whenever the unit is changed it also requires a change of the analogue output scaling. A standard scaling is proposed and the user can change it accordingly.

- **Setting of the humidity unit:** (°Ctd, g/m³, g/kg, ppm etc.) Attention: ppm and g/kg require the input of a reference pressure (actual pressure)
- **Setting of the reference pressure:** Required for ppm and g/kg (actual pressure)
- **Scaling of the analogue output:** Whenever the humidity unit is changed we recommend to adapt the scaling of the analogue output. DS 300 will propose a standard scaling. The scaling is used in order to express the humidity by a 4..20 mA signal which can be transferred to a management system.

Analogue sensors

DS 300 mobile version has 2 analogue input channels at the probe inputs 3 and 4. These channels have to be prepared by **DS 300 configuration software**. The following settings are available by means of the DS 300 configuration software:

- **Show setting:** Sensor type, unit, resolution, input scaling and the date of the last calibration

The following settings can be done at DS 300:

- **Show settings:** Indicates the sensor-specific data
- **Calibration offset:** (Only for current and voltage inputs) The instrument provides a one-point calibration which can eliminate accuracy failures of the instrument and of the sensor. If an accurate reference is available (e. g. in the calibration laboratory) the system can be calibrated at one point to this reference. The calibration is stored inside the DS 300.

Attention: The storage of the calibration in DS 300 mobile version is effected without any allocation to the respective sensor, i. e. if the sensor is changed the one-point calibration is still included and this may lead to incorrect measurements. For this reason please delete the one-point calibration when changing the sensor.



- **Delete calibration offset:** Is used in order to delete the calibration

DS 300 configuration software (including USB cable), order no. 0599 2000

14.2.4 Communication settings

(only available in version RS 485/Modbus)

DS 300 supports RS-485 communication with two protocols available. The user can select between CS-Bus and Modbus. The menu item is available only when RS 485 module is detected.

When entering the menu “communication settings” the submenu will show following selections:

- **Show settings and status:** provides actual protocol settings (read only)
- **Select protocol:** choose between CS-Bus and Modbus
- **Set communication settings:** for Modbus detailed settings can be altered through this selection.

Select protocol

CS-Bus

This protocol is specific for CS products, providing the most complete communication with **CS-Bus** software. Through this protocol a read-out of recorded data and settings of the logging functions are available, which other protocols can not support.

Modbus

This protocol has to be selected if DS 300 is connected to a Modbus system.

Set communication settings

DS 300 comes with a standard Modbus setting which fits in most of the applications. In case DS 300 has to be adjusted to other settings following parameters can be altered:

- **Set transmission mode:** Select between RTU and ASCII
- **Set slave address:** enter slave address between 0...247
- **Set parity / framing:** select parity and number of stop bits
- **Set response delay:** enter the response delay between 0...255 ms
- **Set interframe spacing:** spacing between 3.5...25 characters can be entered

Please refer to the Modbus instruction manual for more details.

14.2.5 System status and settings

| | |
|----------------------------|---|
| Setup time/date | The internal clock can be set. |
| Show system status | For service inquiries this screen contains important information. |
| Change LCD contrast | Contrast of display can be changed. |
| System reset | In case sensors have been changed it's recommended to use this function in order to update system settings. |

14. Scope of delivery

- DS 300 in wall housing according to your order
- fastening clips for panel mounting
- Instruction manual
- Delivery note

15. Order information

| Description | Order no. |
|---|-----------|
| Multifunction measuring instrument DS 300 | 0500 3000 |
| Option with data logger for 1,000,000 Messwerte | Z500 3001 |
| Option RS 485 interface, up 256 DS 300 connectable | Z500 3002 |
| Option 2 analogue inputs (e. g. mA, mV, Pt100, NiCrNi) | Z500 3003 |
| Consumption sensor VA 400, standard version (92.7 m/s), length 220 mm * | 0695 4001 |
| Max. version (185 m/s) | Z695 4003 |
| HighSpeed version (224 m/s) | Z695 4002 |
| Probe length 120 mm | ZSL 0120 |
| Probe length 160 mm | ZSL 0160 |
| Probe length 300 mm | ZSL 0300 |
| Probe length 400 mm | ZSL 0400 |
| VA 410 with integrated 1/4" measuring section * | 0695 0410 |
| VA 410 with integrated 1/2" measuring section * | 0695 0411 |
| VA 410 with integrated 3/4" measuring section * | 0695 0412 |
| VA 410 with integrated 1" measuring section * | 0695 0413 |
| VA 410 with integrated 1 1/2" measuring section * | 0695 0414 |
| Special version for oxygen measurement | 3200 0010 |
| FA 400 dew point sensor for refrigeration dryers, -20...+50 °Ctd * | 0699 0401 |
| FA 400 dew point sensor for adsorption dryers, -80...+20 °Ctd * | 0699 0402 |
| FA 400 dew point sensor, replacement for FA 200, -60...+30 °Ctd * | 0699 0403 |
| FA 410 dew point sensor, -80...+20 °Ctd * | 0699 0410 |
| FA 410 dew point sensor, -20...+50 °Ctd * | 0699 0412 |
| FA 415 dew point sensor * | 0699 0415 |
| FA 416 condensate switch * | 0699 0416 |
| Standard measuring chamber up to 16 bar | 0699 3390 |
| High-pressure measuring chamber up to 350 bar | 0699 3590 |
| Measuring chamber for granulate driers for minimum over pressure | 0699 3490 |
| Measuring chamber for respiratory air bottles up to 350 bar | 0699 3790 |
| Precision pressure sensor CS 16 (0...16 bar) accuracy < 0.5 % * | 0694 3555 |
| Precision pressure sensor CS 40 (0...40 bar) accuracy < 0.5 % * | 0694 3930 |
| Precision pressure sensor CS 1.6 absolute (0...1.6 bar absolute) accuracy < 0.5 % * | 0694 3550 |
| Precision pressure sensor CS 16 (0...16 bar) accuracy < 1 % * | 0694 1886 |
| Precision pressure sensor CS 40 (0...40 bar) accuracy < 1 % * | 0694 0356 |
| Precision pressure sensor CS 1.6 absolute (0...1.6 bar absolute) accuracy < 1 % * | 0694 3551 |
| Clamp-on ammeter 0...1000 A AC incl. 5 m connection cable with open ends | 0554 0504 |
| Screw-in temperature probe Pt100, Class A, length 300 mm, -50...+500 °C * | 0693 0002 |
| Temperature probe cable Pt100, Class A, length 150 mm | 0604 0102 |
| Temperature probe cable Pt100, Class A, length 300 mm | 0604 0100 |
| Thermocouple Type K (NiCr-Ni), Class 1, length 5 m | 0604 0103 |
| Clamp screwing 6 mm, G 1/2", PTFE clamping ring, pressure-tight up to 6 bar | 0554 6003 |
| Clamp screwing 6 mm, G 1/2", VA clamping ring, pressure-tight up to 10 bar | 0554 6004 |

* Attention: Sensor without any connection cable! Please order connection cable separately (see page 45).

| Description | Order no. |
|--|------------------|
| Sets | |
| Flow station DS 300 with consumption counter | 0600 4005 |
| Dew point set FA 410 for adsorption dryers | 0600 0410 |
| Dew point set FA 410 for refrigeration dryers | 0600 0412 |
| Option integrated data logger for 1,000,000 measured values | Z500 3001 |
| <i>Connection cables:</i> | |
| Connection cable for VA/FA Series 400 5 m with M12 plug | 0553 0104 |
| Connection cable for VA/FA Series 400 10 m with M12 plug | 0553 0105 |
| Alarm cable, 5 m, for dew point sensor FA 400 | 0553 0106 |
| Alarm cable, 10 m, for dew point sensor FA 400 | 0553 0107 |
| Connection cable for probes 5 m with open ends (e. g. for pressure sensors) | 0553 0108 |
| Connection cable for probes 10 m with open ends (e. g. for pressure sensors) | 0553 0109 |
| Software: | |
| CS Soft Professional, data evaluation in graphic and table form with USB interface | 0554 7010 |
| CS Soft Professional, RS 485, data evaluation in graphic and table form with RS 485/USB adapter including USB cable and cable A-A for DS 300 | 0554 7020 |
| Calibration of dew point sensors: | |
| Precision calibration at -40 °Ctd including ISO certificate | 0699 3396 |
| Precision calibration at 0°C and 10 °Ctd including ISO certificate | 3200 0003 |
| Control and calibration set 11.3 % RH | 0554 0002 |
| Control and calibration set 33 % RH | 0554 0004 |
| Control and calibration set 75.3 % RH | 0554 0005 |
| Calibration of consumption sensors: | |
| 5-point precision calibration with ISO certificate | 3200 0001 |
| Optional measuring point | on request |
| Real gas calibration | on request |

EC Declaration of Conformity

for

DIRECTIVE 2002/96/EC OF THE EUROPEAN PARLIAMENT AND OF THE COUNCIL of 27. January 2003 on waste electrical and electronic equipment (WEEE)

and

DIRECTIVE 2002/95/EC OF THE EUROPEAN PARLIAMENT AND OF THE COUNCIL of 27. January 2003 on the restriction of the use of certain hazardous substances in electrical and electronic equipment (RoHS)

for the following instruments of CS Instruments GmbH:

Pressure dew point meters: **FA 400, FA 410, FA 415,
FA 416, FA 300-1, FA 300-2,
FA 300-2 Ex, FA 200-2
and accessories**

Flow and consumption meters: **VA 300, VA 400, VA 410,
DS 300
and accessories**

CS Instruments GmbH as the manufacturer herewith declares that the above instruments and accessories belong to the category 9 (WEEE 2002/96/EC). Therefore the above instruments are not affected by the directive RoHS 2002/95/EC and by the material restriction.

In accordance with directive WEEE 2002/96/EC the measuring instruments specified above will be taken back from CS Instruments GmbH for disposal.

CS Instruments GmbH

Harrislee, 27 March 2007

The Management



This declaration does not guarantee any product characteristics.
Please do also adhere to the safety instructions stated in the enclosed documentation.

CS Instruments GmbH

Declaration of Conformity

Pressure dew point meters

**FA 400, FA 410, FA 415, FA 416, FA 300-1, FA 300-2,
FA 300-2 EX, FA 200-2**

Flow- and consumption measurement instrument

VA 300, VA 400, VA 410, DS 300

CS Instruments GmbH as the manufacturer herewith declares that the above measurement instruments complies with the following directive:

| | |
|------------------------------------|--------------------|
| Electro-magnetic compliance | 2004/108/EG |
| Low voltage directive | 2006/95/EG |

For assessing the dew point meters, the following standards have been referred to:

Electromagnetic compatibility

| | |
|---------------------------------|---|
| Emitted interference: | EN 61326: 1997 + A1: 1998 + A2: 2001 + A3:2003 |
| Interference resistance: | EN 61326: 1997 + A1: 1998 + A2: 2001 + A3:2003 |

Low voltage directive

| | |
|--------------------|---|
| Reliability | EN 61010-1: 2001 EN 61010-31: 2002 + A1:2008 |
|--------------------|---|

CS Instruments GmbH
Am Oker 28 c
24955 Harrislee

Tel. 0461 7002025
Fax 0461 7002026

Harrislee, 09. März 2009



Christian Schuldt, Geschäftsführer

This declaration does not guarantee any product characteristics.
Please do also adhere to the safety instructions stated in the enclosed product documentation.

Notes

Notes

Contact

- **Advice**
- **Sale**
- **Service**

Sales office North Germany

CS Instruments GmbH
Am Oxer 28c
D-24955 Harrislee

Phone +49 (0) 461 – 700 2025
Fax +49 (0) 461 – 700 2026

info@cs-instruments.com
www.cs-instruments.com

Sales office South Germany

CS Instruments GmbH
Zindelsteiner Straße 15
D-78052 VS-Tannheim

Phone +49 (0) 7705 – 978 99-0
Fax +49 (0) 7705 – 978 99-20

info@cs-instruments.com
www.cs-instruments.com