

# VA 409

## Flow direction switch for compressed air systems



<b>FUNCTIONS</b>	
	Seite
Introduction	2
Safety Instructions	3
Instruments description/Description of function	4
Technical data	5
Drawing of the instrument/Instruments dimensions	6
Installation description	7
Service information	8
Wiring diagrams	9-16
Warranty	17
Ordering data	17
EC Declarations of conformity	18-19
Contact	20

---

## **INTRODUCTION**

Dear CS customer,

You have made the right decision by choosing a measuring instrument from CS Instruments GmbH. Thousands of customers buy our high standard products every year. There are a few good reasons for doing so:

- The cost-performance ratio - reliable quality at a fair price.
- We have the ideal solutions for your measuring tasks based on our expert experience gained over 20 years.
- Our high quality standard.
- Of course, our instruments carry the CE symbol required by the EU.
- We issue calibration certificates and hold seminars.
- Also after the purchase we do not leave you out in the cold - we offer a good after sales service.



Our service guarantees fast help.

Measuring instrument conforms with **DIN EN 61326**

**Please read carefully before starting the device!**



Warning:

Do not exceed the pressure range of 16 bar. From 10 bar we recommend to use the high-pressure protection for a safe installation and removal.

Observe the measuring ranges of the sensor!

Overheating destroys the sensor.

Observe the admissible storage and transportation temperature as well as the permitted operating temperature (e. g. protect the instrument from direct insolation).

Always observe the direction of flow when positioning the sensor!

The safety ring at the sensor head must always remain undamaged and sit correctly in the destined slot.

The screwed fixture must be pressure tight.

The adapter sleeve must be tightened with a torque of 20 to 30 Nm.

It is absolutely necessary to avoid condensation on the sensor element or water drops in the measuring air as they may cause results .

The values of the inlet and outlet sections must not fall below the specified minimum values.

The manufacturer cannot be held liable for any damage which occurs as a result of non-observance or non-compliance with these instructions. Should the device be tampered with in any matter other than a procedure which is described and specified in the manual, the warranty is cancelled and the manufacturer is exempt from liability.

The device is destined exclusively for the described application.

CS Instruments GmbH offers no guarantee for the suitability for any other purpose and is not liable for errors which may have slipped into this operation manual. CS Instruments GmbH is also not liable for consequential damage resulting from the delivery, capability or use of this device.

We offer you to take back the instruments of the instruments family VA 409 which you would like to dispose of.

Adjustments and calibrations should only be carried out by qualified employees from the measurement and control technology branch.

### VA 409 flow direction switch for compressed air systems

The new thermal flow direction switch VA 409 with direction indication serves for detection of the flow direction of compressed air and gases especially in closed circular pipelines.

By means of VA 409 with direction indication the flow direction of the compressed air will be detected quickly and safely. Compared with the former mechanical paddle flow switches VA 409 detects even the smallest changes in the flow direction quickly and without mechanical movement.

The direction information in form of a potential-free contact (opener max. 60 VDC, 0.5 A) is transferred to the consumption sensors VA 400/VA 420 or to a separate building management system (bms). Two LEDs show the flow direction.

In connection with two consumption sensors VA 400/VA 420 incoming and outflowing compressed air in closed circular pipelines can be measured precisely.

#### Special features

- detects smallest changes from  $\leq 0.1$  m/s referred to 20 °C and 1000 mbar
- no mechanical wear parts
- easy installation under pressure

#### Description of function:

##### LED ON:

- LED active: Instrument ready for operation
- When switching on the instrument the LED flashes for five seconds
- LED flashes constantly: Instruments fault

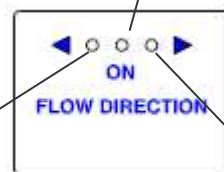

LED is on in case of flow direction from the right to the left, contact opens (see page 6)

LED is on in case of flow direction from the left to the right, contact opens (see page 6)

If there is no flow both direction LEDs are switched off

---

<b>Reaction range</b>	
<b>recognition flow direction:</b>	<b>&lt; 0.1 m/s referred to 20 °C and 1000 mbar</b>
<b>Measuring principle:</b>	<b>calorimetric measurement</b>
<b>Sensor:</b>	<b>Pt30/Pt700/Pt330</b>
<b>Measuring medium:</b>	<b>Air, gases</b>
<b>Operating temperature:</b>	<b>0 ... 50 °C probe tube -20 ... 70 °C housing</b>
<b>Operating pressure:</b>	<b>up to 16 bar</b>
<b>Power supply:</b>	<b>24 VDC, 40 mA</b>
<b>Power input:</b>	<b>max. 80 mA at 24 VDC</b>
<b>Protection class:</b>	<b>IP 54</b>
<b>EMV:</b>	<b>according to DIN EN 61326</b>
<b>Connection:</b>	<b>2 x M 12, 5-pole, plug A and plug B</b>
<b>2 potential-free switch contacts:</b>	<b>2 x U max. 60VDC, I max. 0.5 A (normally closed) On request: Normally open</b>
<b>Housing:</b>	<b>Polycarbonate</b>
<b>Probe tube:</b>	<b>Stainless steel 1,4301, length 160 mm, Ø 10 mm Safety ring Ø 12 mm Longer probes on request</b>
<b>Mounting thread:</b>	<b>G 1/2"</b>
<b>Diemater housing:</b>	<b>65 mm</b>
<b>Direction indication:</b>	<b>2 LEDs</b>

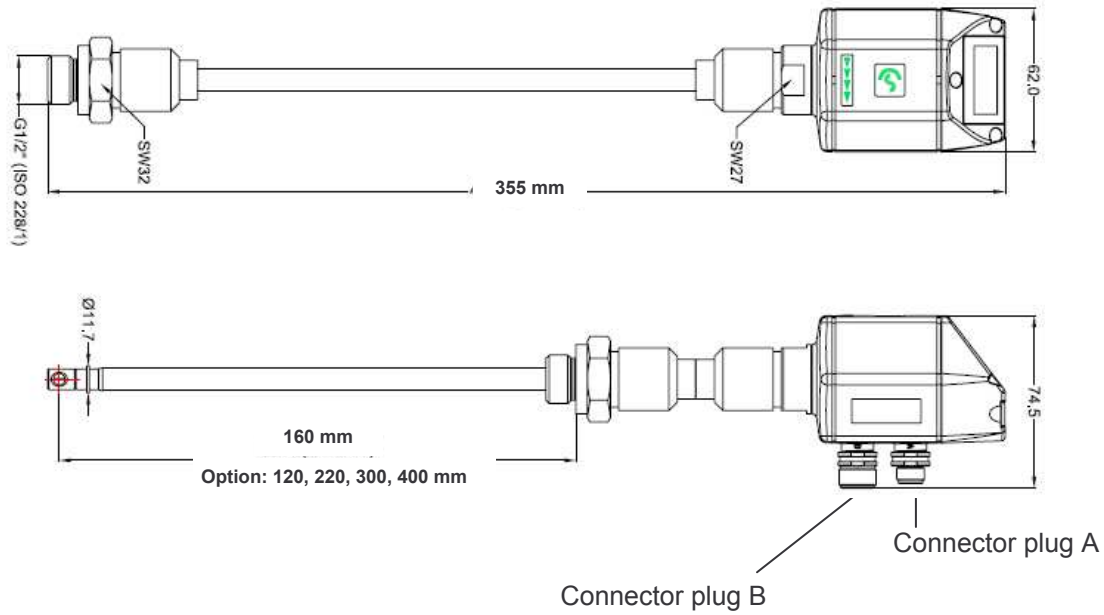
**DRAWING OF THE INSTRUMENT/INSTRUMENTS DIMENSIONS**

		Pin 1	Pin 2	Pin 3	Pin 4	Pin 5
VA 409	<b>Connector plug A</b>	GND -VB 0 V	Contact open in case of flow direction from the left to the right		NC	+24 VDC +VB
	<b>Connection cable A</b> 0554.0104 (5 m) 0554.0105 (10 m)	brown	white	blue	black	grey
	<b>Connector plug B</b>	NC	Contact open in case of flow direction from the right to the left		NC	NC

GND, -VB	Negative supply voltage 0 V
+VB	Positive supply voltage 12...30 VDC smoothed
Pin 2, Pin 3	Opener, contact opens from $\leq 0.1$ m/s, max. 60 VDC, 0.5 A
NC	Not connected

**M12 connector plug A**

If no connection cable ( 0553 0104, 0553 0105 ) is ordered the sensor will be supplied with a M12 connector plug. The user can connect the supply and signal cables as indicated in the connection diagram.

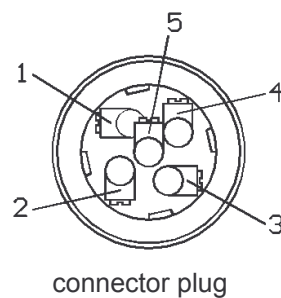

**Instruction for installation of the flow direction switch VA 409**

**Please read before putting into operation!**

1. Do not exceed pressure range > 16 bar
2. Observe flow direction of the flow direction switch, see direction arrows
3. The clamping sleeve must be tightened with a torque of 20 to 30 Nm
4. From the view of the flow direction of the gas the flow direction switch has to be installed behind the consumption sensor VA 400/VA 420
5. Please observe minimum distance  $5 \times D_i$  (inner diameter) to the consumption sensor VA 400/VA 420
6. The flow direction switch is only allowed to be installed into horizontal pipelines

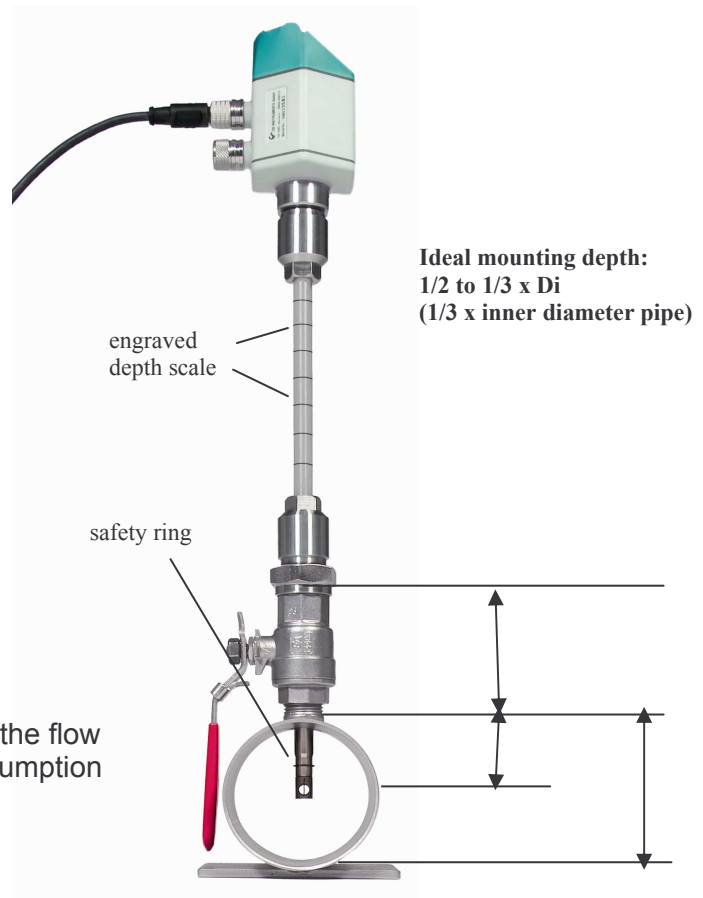

**Attention:**

To avoid flow turbulences always install the flow direction switch VA 409 behind the consumption sensors VA 400/VA 420.

**Assembly instructions**

**Safety information must be observed.**

Assembly is carried out by inserting the connection thread ( $1/2''$  thread, SW 27) into the connection piece. The sensor is then inserted to the required immersion depth and aligned according to the direction of air flow. A depth scale engraved on the probe tube, a flow alignment arrow and an aligning device will be of help to you. Once the sensor has been aligned, the adapter sleeve must be tightened with the stipulated torque (SW 17).  
 Attention: Alignment of the sensor must not be modified when tightening the connection thread and adapter sleeve. In this case please check the immersion depth and alignment again and correct if necessary. The angular deviation should not be greater than  $\pm 2^\circ$  in relation to the ideal position as otherwise the measuring accuracy will decrease.

**Maintenance**

The sensor head should be checked regularly for dirt and cleaned if necessary. Should dirt, dust or oil accumulate on the sensor element, a deviation will occur in the measuring value. An annual check is recommended. Should the compressed air be heavily soiled this interval must be shortened.

**Cleaning of the sensor head**

The sensor head can be cleaned by carefully moving it to and fro in warm water with a small amount of washing-up liquid. Avoid physical intervention on the sensor (e. g. using a sponge or brush). If soiling cannot be removed, service and maintenance must be carried out by the manufacturer.

**Re-calibration**

If no customer specifications are given then we recommend to carry out calibration every 12 months. For this purpose the sensor must be sent to the manufacturer.

**Spare parts and repair**

For reasons of measuring accuracy spare parts are not available. If parts are faulty they must be sent to the supplier for repair.

If the measuring device is used in important company installations we recommend to keep a spare measuring system ready.

**Calibration certificates**

Calibration certificates are issued by the manufacturer on request. This is a fee-paying service. Precision is tested with PTB (German National Metrology Institute) volume flow nozzles.

Consumption sensor VA 400 and flow direction switch VA 409

Für diese Zeichnung gelten die Bestimmungen über den Schutz für Urheberrecht.

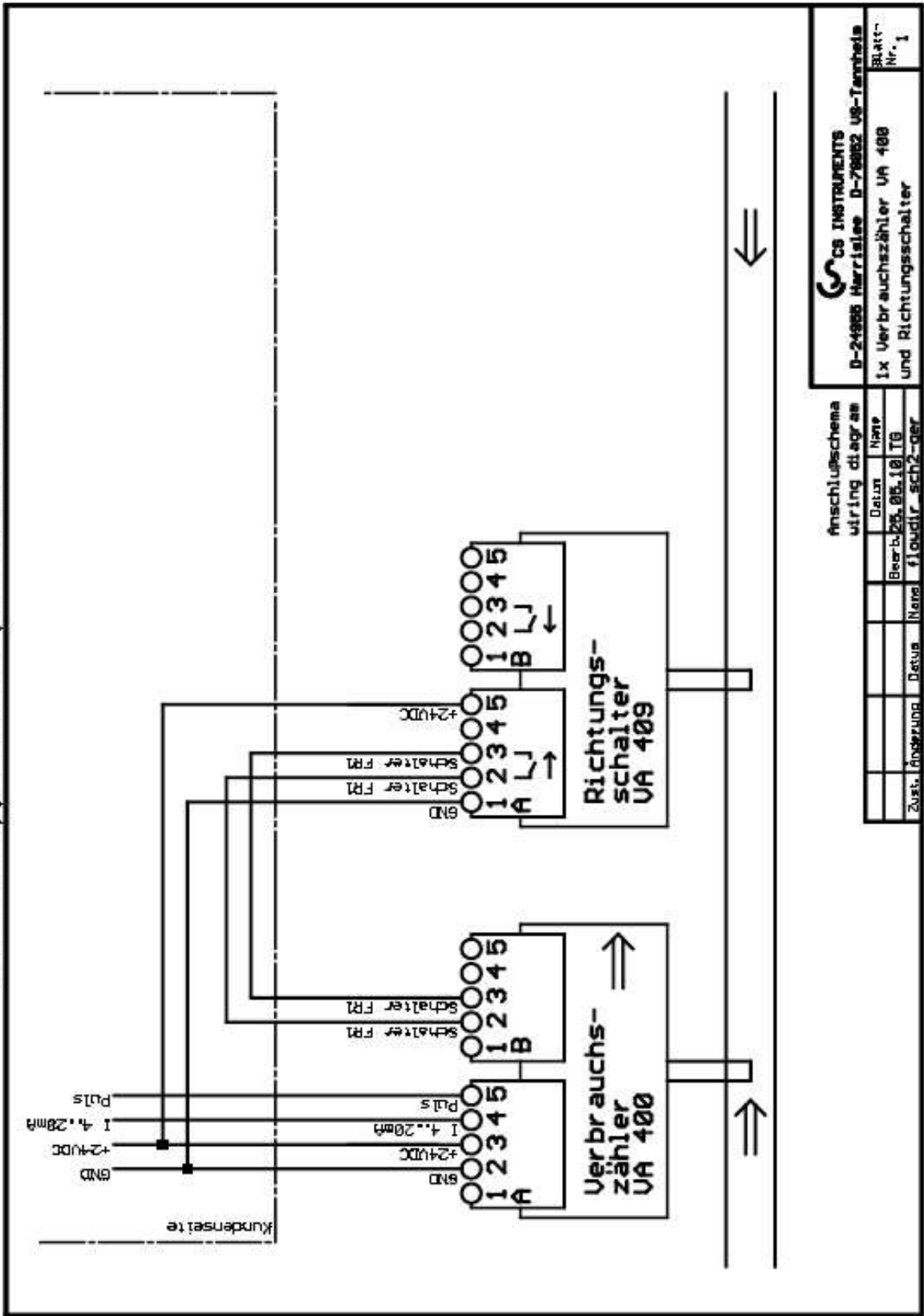



2 x consumption sensor VA 400 and flow direction switch VA 409

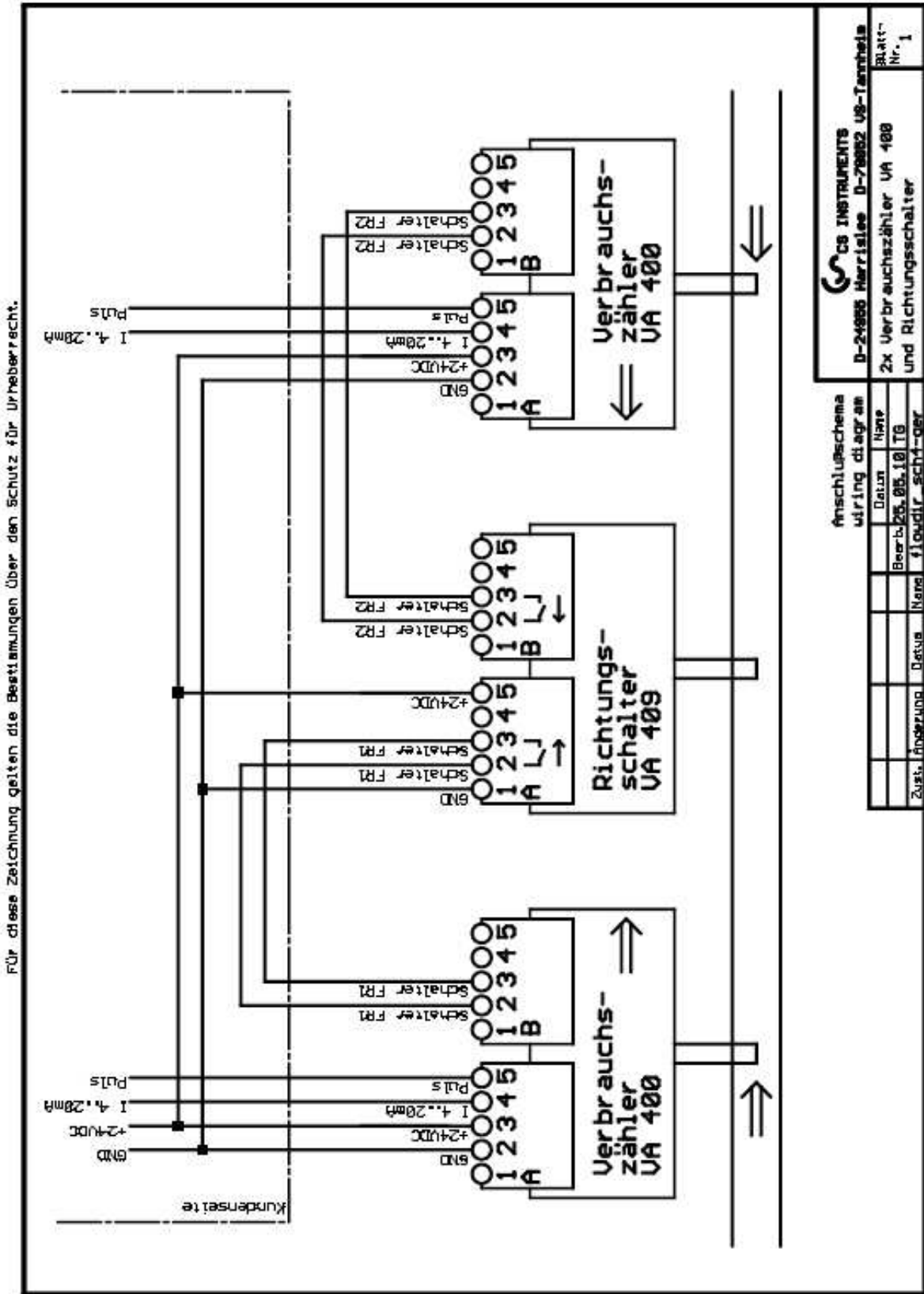



Display set DS 300 with VA 400 and flow direction switch VA 409

Für diese Zeichnung gelten die Bestimmungen über den Schutz für Urheberrecht.

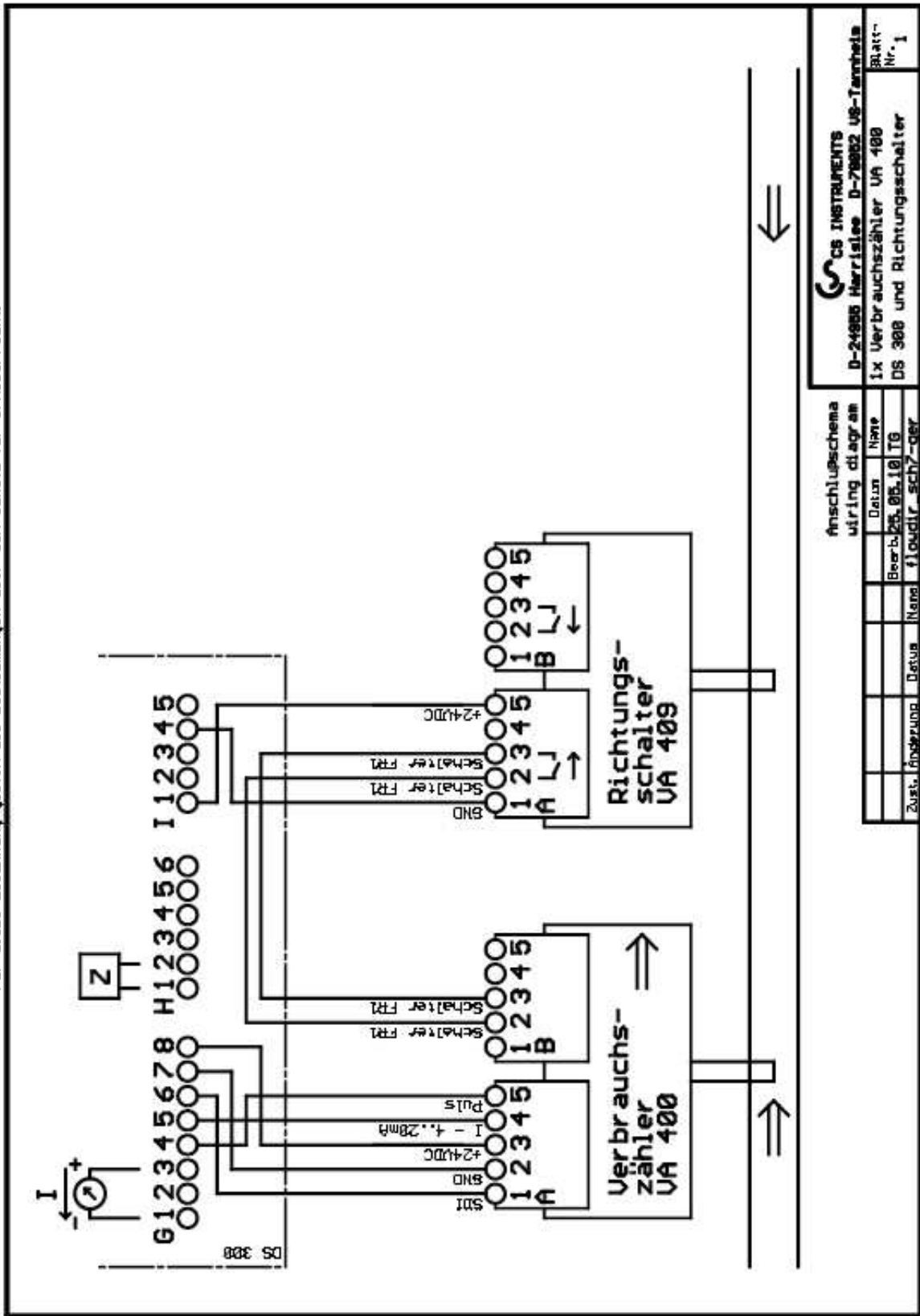

Display set DS 300 with VA 420 and flow direction switch VA 409

Für diese Zeichnung gelten die Bestimmungen über den Schutz für Urheberrecht.

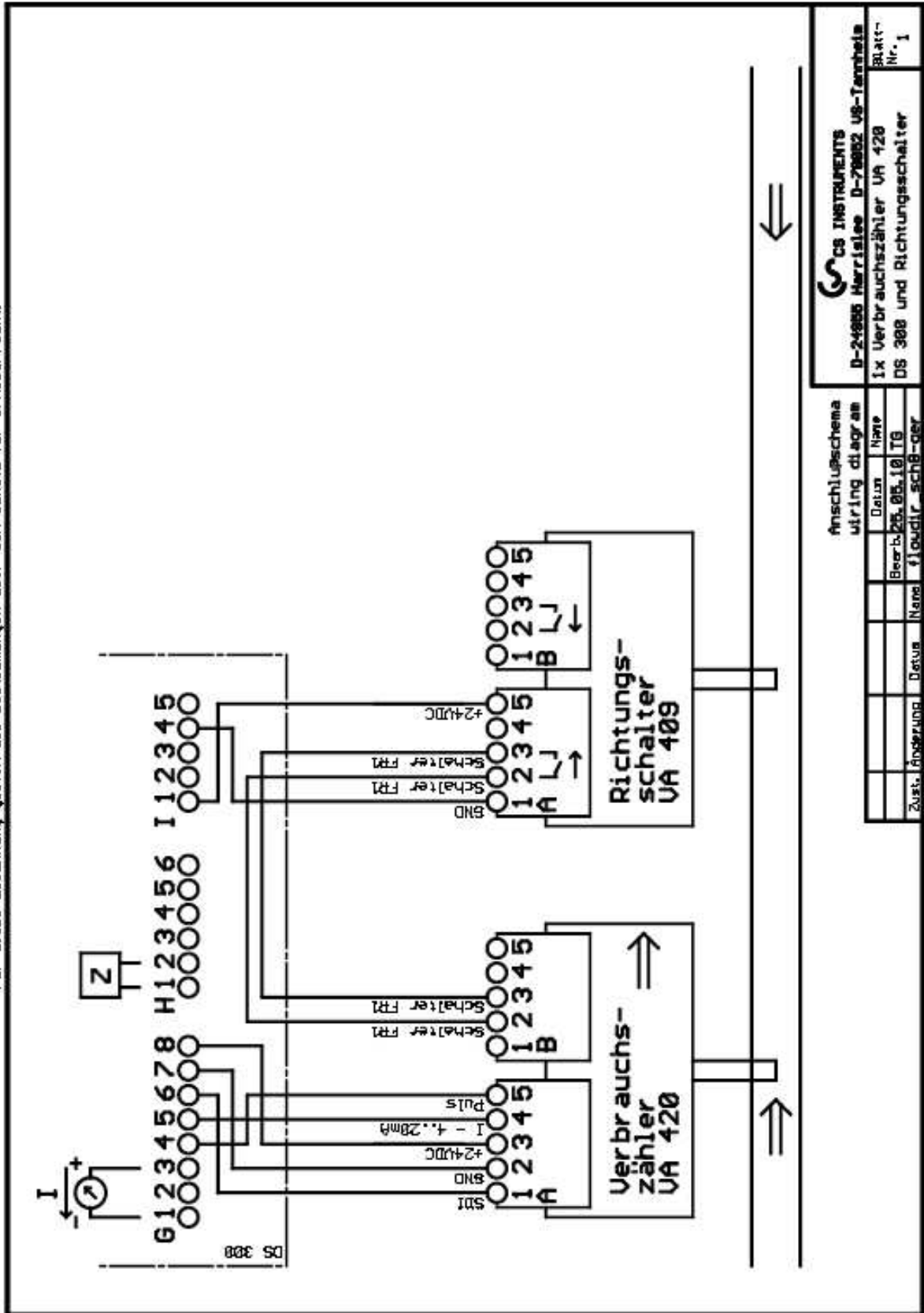

Anschiußschema		wiring diagram	
Zust.	Änderung	Datum	Name
		25.05.10	ITB
Besch.		1x Verbrauchszähler VA 420	
Blatt-Nr.		DS 300 und Richtungsschalter	
Blatt-Nr.		Nr. 1	

2 x display set DS 300 with VA 400 and flow direction switch VA 409

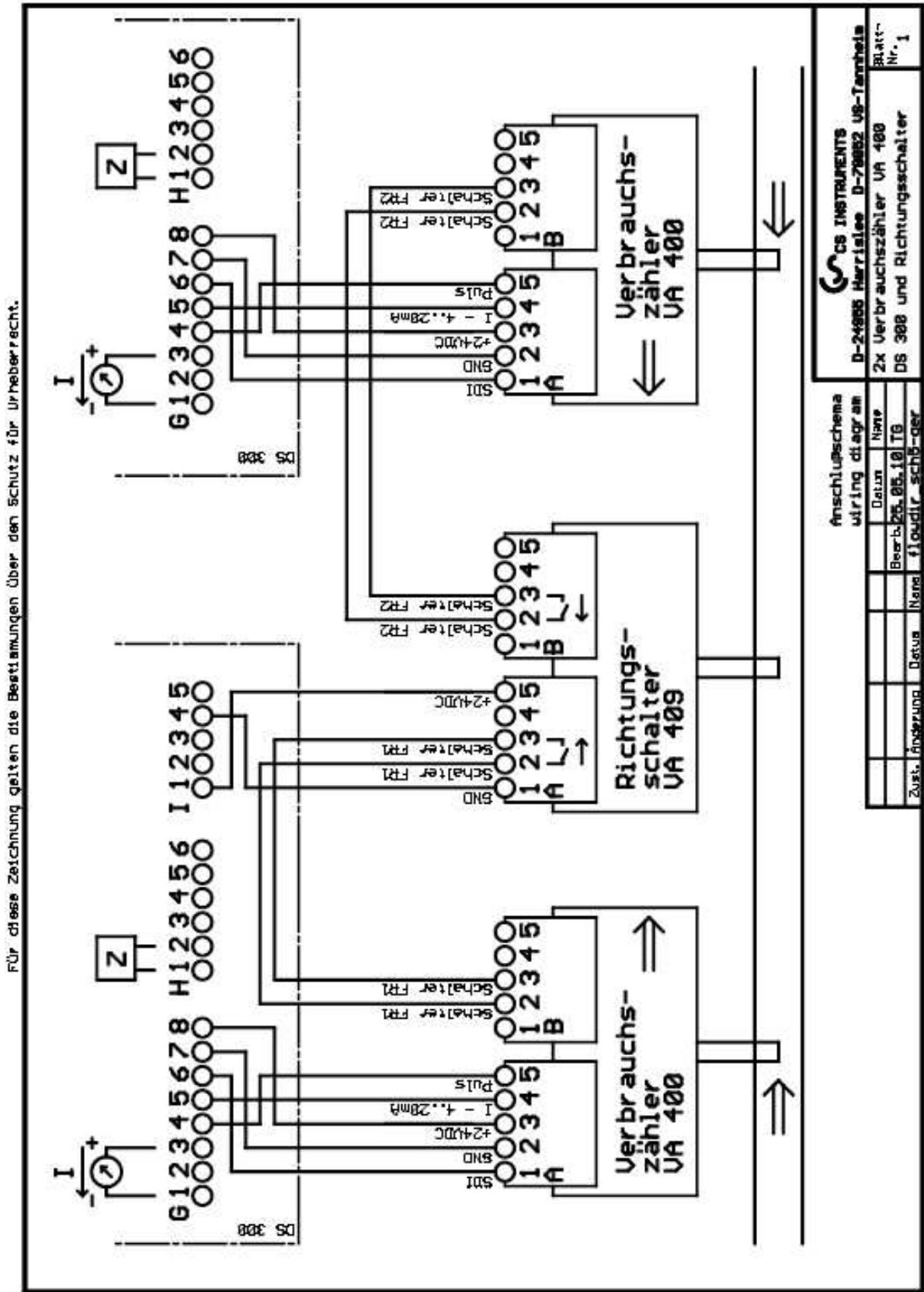



---

**WARRANTY**

If you have reason for complaint we will of course repair any faults free of charge if it can be proven that they are manufacturing faults. The fault should be reported immediately after it has been found and within the warranty time guaranteed by us. Excluded from this warranty is damage caused by improper use and non adherence to the instruction manual.

The warranty is also cancelled once the instrument has been opened - as far as this has not been mentioned in the instruction manual for maintenance purposes - or if the serial number in the instrument has been changed, damaged or removed.

The warranty time for the VA 400 is 12 months. If no other definitions are given the accessory parts have a warranty time of 6 months. Warranty services do not extend the warranty time.

If in addition to the warranty service necessary repairs, adjustments or similar are carried out the warranty services are free of charge but there is a charge for other services such as transport and packaging costs. Other claims, especially those for damage occurring outside the instrument, are not included unless responsibility is legally binding.

**After sales service after the warranty time has elapsed**

We are of course there for you even after the warranty time has elapsed. In case of malfunctions please send us the instrument with a short-form description of the fault. Please do not forget to indicate your telephone number so that we can call you in case of any questions.

---

**ORDERING DATA**

<i>Order no.</i>	<i>Description</i>
0695.0409	Flow direction switch VA 409
0554.0108	Mains unit in wall housing im Wandgehäuse
0553.0104	Connection cable for VA/FA Series 400, 5 m with M12 plug
0553.0105	Connection cable for VA/FA Series 400, 10 m with M12 plug
0695.4001	Consumption sensor VA 400 without display including plug
Optionen:	
Z695.4000	Display for VA 400
Z695.4003	Max. version VA 400 (185 m/s)
Z695.4002	High-Speed version VA 400 (224 m/s)
ZSL.0120	VA 400 sensor length 120 mm
ZSL.0160	VA 400 sensor length 160 mm
ZSL.0220	VA 400 sensor length 220 mm
ZSL.0300	VA 400 sensor length 300 mm
ZSL.0400	VA 400 sensor length 400 mm
0500.3000	DS 300 display, wall mountable

## EC Declaration of Conformity

for

**DIRECTIVE 2002/96/EC OF THE EUROPEAN PARLIAMENT AND OF THE COUNCIL  
of 27. January 2003  
on waste electrical and electronic equipment (WEEE)**

and

**DIRECTIVE 2002/95/EC OF THE EUROPEAN PARLIAMENT AND OF THE COUNCIL  
of 27. January 2003  
on the restriction of the use of certain hazardous substances in electrical and electronic equipment  
(RoHS)**

for the following instruments of CS Instruments GmbH:

Pressure dew point meters: **FA 400, FA 410, FA 415,  
FA 416, FA 300-1, FA 300-2,  
FA 300-2 Ex, FA 200-2  
and accessories**

Flow and consumption meters,  
flow direction switch **VA 300, VA 400, VA 409,  
VA 410, VA 420, DS 300  
and accessories**

CS Instruments GmbH as the manufacturer herewith declares that the above instruments and accessories belong to the category 9 (WEEE 2002/96/EC). Therefore the above instruments are not affected by the directive RoHS 2002/95/EC and by the material restriction.

In accordance with directive WEEE 2002/96/EC the measuring instruments specified above will be taken back from CS Instruments GmbH for disposal.

CS Instruments GmbH

Harrislee, 27 March 2007

The Management



This declaration does not guarantee any product characteristics.  
Please do also adhere to the safety instructions stated in the enclosed documentation.

# CS Instruments GmbH

## Declaration of Conformity

Flow direction switch for compressed air     **VA 409**

CS Instruments GmbH as the manufacturer herewith declares that the above flow direction switch complies with the following directives :

Electro-magnetic compliance	2004/108/EG
Low voltage directive	2006/95/EG

For assessing the instrument, the following standards have been referred to:

Electromagnetic compatibility

Emitted interference:	EN 61326-1: 2006-10 + EN 61326-1/Ber.1: 2008-0
Interference resistance:	EN 61326-1: 2006-10 + EN 61326-1/Ber.1: 2008-07

Low voltage directive

Reliability	EN 61010-1: 2002-08 + EN 61010-1/Ber.1:2002-11 + EN 61010-1/Ber.2:2004-01
-------------	------------------------------------------------------------------------------

CS Instruments GmbH  
Zindelsteiner Str. 15  
78052 VS-Tannheim  
Phone: +49 (0)7705 978 99-0  
Fax: +49 (0)7705 978 99-20

Tannheim, 19. May 2010



Wolfgang Blessing, Managing Director

This declaration does not guarantee any product characteristics.  
Please do also adhere to the safety instructions stated in the enclosed product documentation.

**Sales office SOUTH**

Zindelsteiner Str. 15  
78052 Villingen-Schwenningen

Phone +49 (0) 7705 97 89 9-0  
Fax +49 (0) 7705 97 89 9-20

[info@cs-instruments.com](mailto:info@cs-instruments.com)  
[www.cs-instruments.com](http://www.cs-instruments.com)

**Sales office NORTH**

Am Oxer 28c  
24955 Harrislee

Phone +49 (0) 461 700 20 25  
Fax +49 (0) 461 700 20 26

[info@cs-instruments.com](mailto:info@cs-instruments.com)  
[www.cs-instruments.com](http://www.cs-instruments.com)