

Instruction manual

Drilling jig

For a later setting up of a measuring place



Contact

Dear customer,

Thank you very much for deciding in favour of the drilling jig for setting up a measuring place. Please read this instruction and installation manual carefully before installation and initiation and observe our notes. Only a careful observation of the described instructions and notes grants a proper function of the drilling jig and a riskless operation.

1 Contact

Advice

Sale

Service

Seminars

Sales office North

CS Instruments GmbH

Am Oxer 28c

24955 Harrislee/GERMANY

Phone +49 (0) 461 700 20 25

Fax: +49 (0) 461 700 20 26

info@cs-instruments.com

www.cs-instruments.com

Sales office South

CS Instruments GmbH

Zindelsteiner Str. 15

78052 VS-Tannheim/GERMANY

Phone +49 (0) 7705 978 99-0

Fax +49 (0) 7705 978 99-20

info@cs-instruments.com

www.cs-instruments.com

1	Contact	2
2	Safety	4
3	Field of application	5
4	Drilling after welding on a nozzle	5
5	Drilling upon installation of a spot drilling collar	6
6	Technical data	7
7	Scope of delivery.....	8

2 Safety



Please check whether this manual corresponds with the instruments type.

Please observe all notes indicated in this instruction manual. It contains essential information which have to be observed during installation, operation and maintenance. Therefore this instruction manual has to be read categorically by the technician as well as by the responsible user / qualified personnel before installation, initiation and maintenance.

This instruction manual has to be available at the operation site of the drilling jig at any time.

Regional respectively national regulations have to be observed in addition to this instruction manual if necessary.

In case of any obscurities or questions with regards to this manual or to the instrument please contact CS Instruments.



Warning!

Compressed air !

Contact with quickly or abruptly escaping compressed air or bursting parts of the system may cause severe injuries or death.

Measures:

- Do not exceed the maximum operation pressure of 10 bar!
- Wear protective goggles!
- Only use pressure-tight installation material!
- Void persons or objects being hit by escaping compressed air!



Warning !

Inadmissible operating parameters!

Undercutting respectively exceeding of limit values may cause danger to persons and material and may lead to functional and operational disturbances.

Measures:

- Make sure that the drilling jig is only operated within the admissible limit values.
- Careful observation of the performance data in connection with the application.

Further safety instructions:

- Installation should only be carried out by authorized qualified persons
- Observe all safety regulations for works at compressed air carrying lines
- The drilling jig has to be mounted pressure-tightly
- Use slowly running drilling machine with corresponding safety installations
- National (safety) regulations have to be observed also during installation and operation

3 Field of application

- The drilling jig is designed for the later setting up of a measuring place in a pressurized line. For the drilling under pressure we recommend two possibilities:
 - Welding of a 1/2" nozzle for mounting a ball valve
 - Previous installation of a spot drilling collar with 1/2" ball valve

4 Drilling after welding on a nozzle

1. Weld on the nozzle.

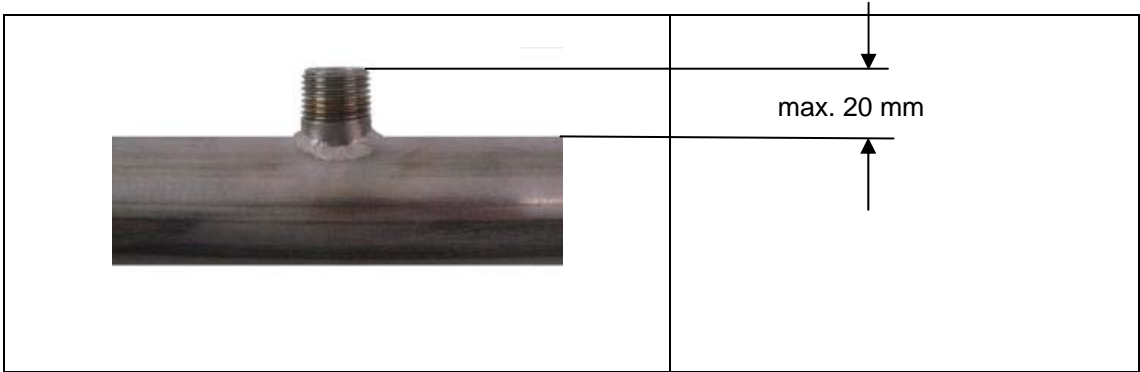

2. Mount the 1/2" ball valve pressure-tightly
3. Screw-on the drilling jig pressure-tightly onto the ball valve.
(if necessary remove existing chippings from the drilling jig)

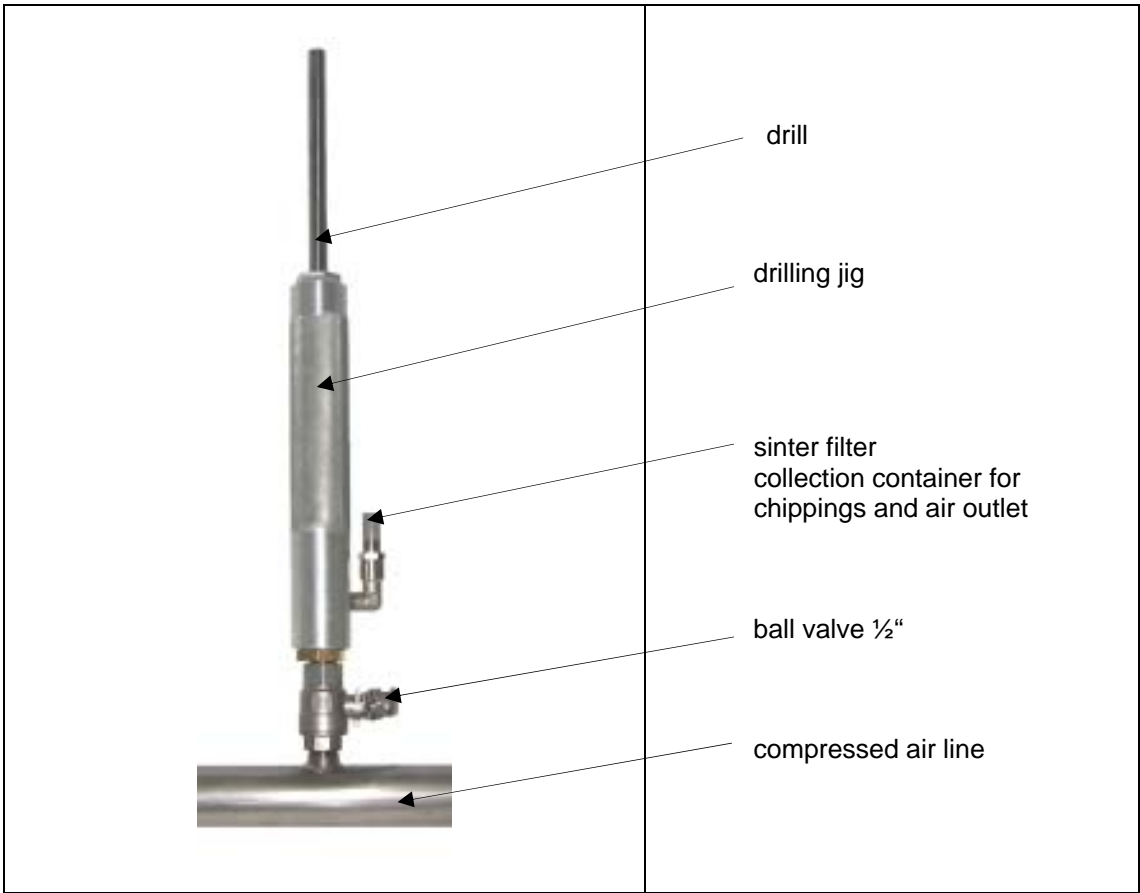

Drilling upon installation of a spot drilling collar

4. Install drilling machine
5. Open ball valve
6. Drill the hole with low speed level.
Please observe during drilling: Pull back the drill shortly approx. every 10 seconds so that the chippings are fed to the collection container (sinter filter).
7. When the pipe is drilled through pull back the drill as far as it will go.
8. Close the ball valve
9. Disassemble drilling jig

Before carrying out the next step please observe implicitly:

Wear protective goggles!

Attach a compact cloth at the outlet of the ball valve before opening the ball valve for protection against outcoming chippings.



10. Open the ball valve once again and blow out the chippings
11. Screw off the sinter filter from the lateral air outlet, take out the chippings and close the air outlet.

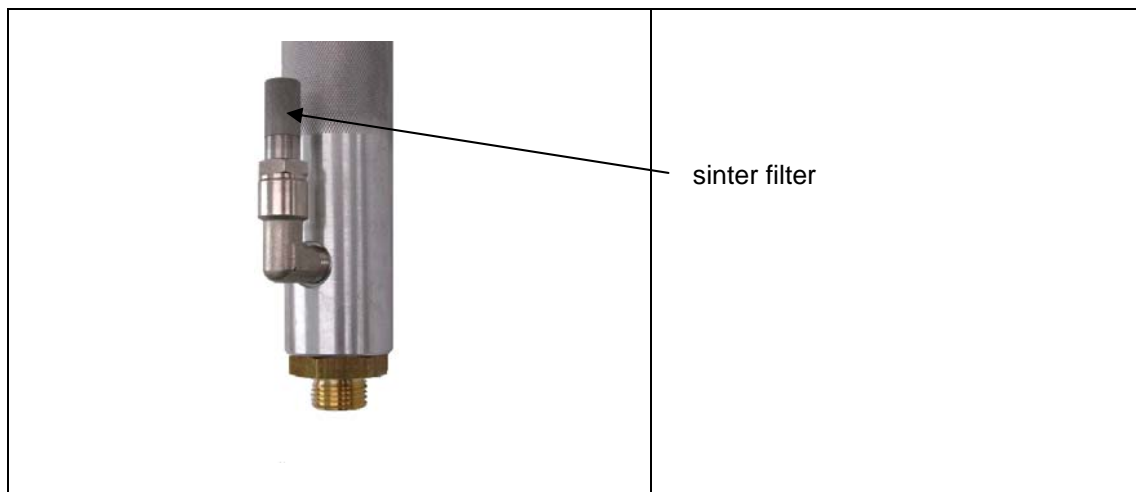

5 Drilling upon installation of a spot drilling collar

Installation of the spot drilling collar please see instruction manual „Spot drilling collars“



1. Install spot drilling collar according to mounting instructions
2. Mount ½“ ball valve pressure-tightly
3. Screw the drilling jig pressure-tightly onto the ball valve.
(remove any existing chippings from the drilling jig before doing so)

4. Install drilling machine
5. Open ball valve
6. Drill the hole with low speed level.
Please observe during drilling: Pull back the drill shortly approx. every 10 seconds so that the chippings are forwarded to the collection container (sinter filter).
7. When the pipe is drilled through pull back the drill as far as it will go.
8. Close the ball valve
9. Disassemble drilling jig

Before carrying out the next step please observe implicitly:

Wear protective goggles!

Attach a compact cloth at the outlet of the ball valve before opening the ball valve for protection against outcoming chippings.



10. Open the ball valve once again and blow out the chippings
11. Screw off the sinter filter from the lateral air outlet, take out the chippings and close the air outlet

6 Technical data

Diameter of drill	13.0 mm
Length of drill	450 mm
Material of drill	HSS/ E
Max. operating pressure	10 bar
Dimensions	(450x40x45)mm
Housing material	Al

7 Scope of delivery

Drilling jig	
Drilling jig including drill Ø13	0530 1108

Spot drilling collars incl. ball valve 1/2", I/A	
For outer pipe diameters from – to	Order no.
026 – 030 mm	0500 0447
032 – 036 mm	0500 0446
036 – 040 mm	0500 0448
040 – 044 mm	0500 0449
048 – 052 mm	0500 0450
050 – 057 mm	0500 0451
056 – 063 mm	0500 0452
058 – 065 mm	0500 0453
067 – 074 mm	0500 0454
073 – 080 mm	0500 0455
076 – 083 mm	0500 0456
082 – 089 mm	0500 0457
087 – 094 mm	0500 0458
091 – 098 mm	0500 0459
095 – 102 mm	0500 0460
102 – 112 mm	0500 0461
108 – 118 mm	0500 0462
118 – 128 mm	0500 0463
125 – 135 mm	0500 0464
132 – 142 mm	0500 0465
138 – 148 mm	0500 0466
145 – 155 mm	0500 0467
151 – 161 mm	0500 0468
159 – 170 mm	0500 0469
167 – 177 mm	0500 0470
176 – 186 mm	0500 0471
193 – 203 mm	0500 0472
200 – 210 mm	0500 0473
209 – 219 mm	0500 0474
Other diameters on request	

Leak detector	
LD 300 leak detector	0601 0103
Telescope bar 3 x 120 cm	0530 0102

Notes

Notes

C		O	
Chippings.....	7	Outer pipe diameters	8
Collection container for chippings	7	P	
Contact	2	Protective goggles	7
D		S	
Diameter of drill	7	Safety instructions.....	4
Dimensions	7	Scope of delivery	8
Drilling after welding on a nozzle.....	5	Sinter filter	7
Drilling upon installation of a spot drilling collar	6	Speed level	7
F		T	
Field of application.....	5	Technical data.....	7
M		W	
Max. operating pressure.....	7	Warning compressed air	4



Technical changes and errors excepted.
IM_drilling_jig_EN_V2_01_2009