

FO 510

The **CS INSTRUMENTS moisture in oil transmitter FO510** with two analog outputs for different measured variables and RS 485 Modbus interface as standard, enables reliable and long-term stable measurement in technical oils.

Developed for measurements such as the moisture content in transformer, motor, lubricating or hydraulic oil, as well as diesel fuels.



Inhalt

1	Foreword	3
2	Intended use.....	3
3	Safety instructions	3
4	Description	4
5	Technical data	5
6	Dimension / elektr. Connection.....	6
7	Installationshinweise	7
8	Modbus.....	8
8.1	Register Mapping measuring values:	8
8.2	Registermapping device settings	9
	Modbus Settings (2001...2006)	9
8.3	Analog Scaling Settings (2007...2011).....	9
9	Calibration / Adjustment	10
10	Warranty.....	10

1 Foreword

Dear Customer,

Thank you for purchasing the FO 510. Please read these installation and operating instructions carefully before installation and commissioning and follow our instructions. The FO 510 will only function properly and operate safely if the instructions and notes described are strictly observed.

2 Intended use

The FO510 is intended for measuring moisture in technical oils.

A check whether the device is suitable for the selected application must be carried out by the user. It must be ensured that the medium is compatible with the wetted parts. The technical data listed in the data sheet are binding.

Improper handling or operation outside the technical specifications is not permitted. Claims of any kind due to improper use are excluded.

3 Safety instructions



Before installing the FO 510, read these operating instructions carefully. Failure to follow the instructions in this manual, in particular the safety instructions, may result in danger to personnel, equipment, and installations.

- The product may only be used and applied in accordance with its intended use.
- Installation of the moisture in oil sensor) and maintenance work may only be carried out by trained personnel.
- Installation and service work must be carried out in a de-energized state.
- The applicable safety regulations must be observed!
- Attention: max. pressure range 300 bar must not be exceeded.
- Observe the measuring ranges of the sensor!
Overheating will destroy the sensors.
- Observe the permissible storage and transport temperature as well as the permissible operating temperature (e.g. protect the measuring device from direct sunlight).
- Opening the device, improper handling or use of force will void the warranty!

4 Description

The FO 510 humidity and temperature transmitter is a reliable measuring device that can be used in various applications.

It is a microprocessor-controlled device that enables moisture measurement in the form of water activity or relative humidity. This is particularly useful in areas such as the lubrication of circulation systems or in oil transformers.

The analog interfaces with two current outputs can be freely configured, while a digital output (RS-485) is also available.

Connection options (ISO and NPT 1/2).

In addition, the FO 510 enables precise temperature measurement and is designed as an easy-to-install online probe.

Special advantages of the FO 510 oil sensor

- Measured variables: Water activity (a_w), temperature (t) and water content in PPM (x) (for transformer oils)
- Fast Response time
- Two freely configurable analog outputs as well as Modbus-RTU (RS 485) interface available)

The FO 510 is used to measure the moisture content in oil using water activity (a_w) and relative humidity (%rH). Using internal calculations on specific oil parameters, the FO 510 can also measure oil moisture in ppm (supported as standard for mineral transformer oil).

The water activity is measured on a scale from 0 to 1 a_w , where 0 a_w stands for completely water-free oil and 1 a_w indicates that the oil is completely saturated with water. The relative humidity indicates the water content on a scale from 0 to 100 %rH, where 0 %rH stands for completely water-free oil and 100 %rH indicates that the oil is completely saturated with water.

If the water activity exceeds 0.9 a_w or the relative saturation exceeds 90 % rH, there is a risk of segregation in the system, especially at falling temperatures.

The water activity and relative humidity serve as critical parameters to indicate risks of free water in the system, especially when they reach values of $>0.9 a_w / >90 \%rH$.

The key advantages of this measuring system are that water activity and relative saturation are independent of oil ageing and immune to additives.

The FO 510 transmitter enables continuous online measurements and can also be calibrated with salt solutions without the need for reference oils.

Programming by software.

With the CS Service Software incl. USB / Modbus adapter settings like Modbus settings can be changed, analog output can be rescaled, and measured values can be assigned to adapt these oil specific parameters for different oil types.

5 Technical data

Measuring range humidity	0...1 a _w
Accuracy (0...0.9 a _w)	±0.02 Accuracy (0...0.9 a _w) at 23°C
Accuracy (0.9...1.0 a _w)	typically ± 0.03 a _w at 23°C
Measuring range temperature:	0...100°C
Accuracy :	±0.3°C
Perm. oil temperature:	-20...100°C
Perm. ambient temperature:	-20...70°C
Storage temperature :	-40...80 °C
Pressure range :	up to 300 bar
Power supply :	24VDC (10...30 VDC)
Output :	2x 4...20 mA (3-wire-Technology) RS 485 (Modbus RTU)
Protection class:	IP 66
Load for analogue output:	< 500 Ohm
Screw in thread:	G 1/2" Optional: NPT ½ "
Material case :	Zinc die casting
Wetted parts:	Sensor protection Perforated cap 1.4301 (SS304) Process connection (screw-in thread) 1.4404 (SS 316L)
Electr. connection:	M12, 8-pin, A-Coding
EMC:	DIN EN 61326-1

6 Dimension / elektr. Connection



Dimension

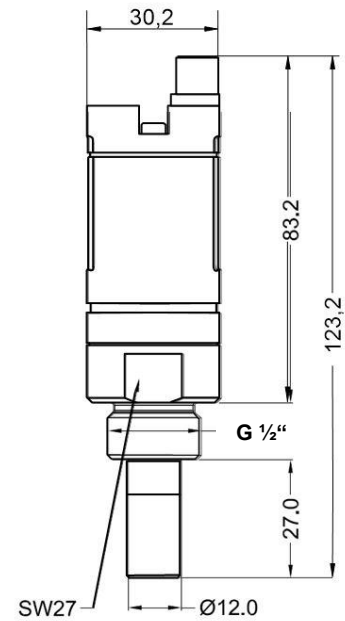

Pin 1	Pin 2	Pin 3	Pin 4	Pin 5	Pin 6	Pin 7	Pin 8
NC	RS485 (B)	RS485 (A)	+I output	+I output	-VB	NC	+VB

+VB	Positive supply voltage 24VDC (10...30 VDC) smoothed
RS485 (A)	Modbus A (+)
-VB	Negative supply voltage
RS 485 (B)	Modbus B (-)
+I	Positive 4...20 mA Signal **
NC	not connected

** Measuring value assignment for 4-20mA signal selectable

M12 Connector

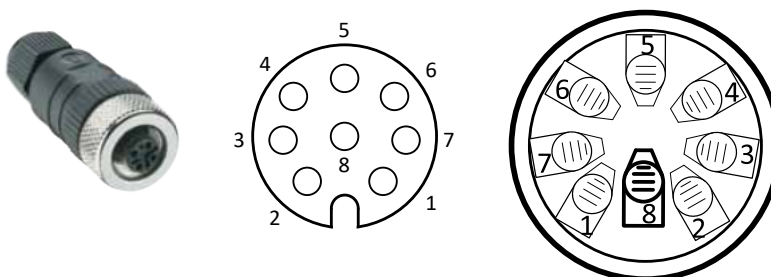

Connection diagram

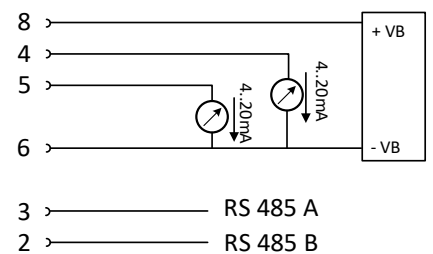

Note: The sensor may only be connected in a de-energized state.

7 Installationshinweise



- The direct installation of the sensor is only allowed in the unpressurized state of the system.
- The sensor must be tightened with a torque of 25 - 30 Nm.
- Tightness of the connection must be checked and ensured.
- It is not permitted to use a sealing ring with an NPT 1/2". Instead, use a suitable PTFE sealing tape or sealant.

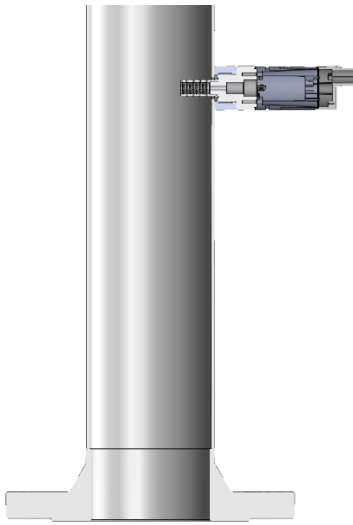

Screw the sensor with the G 1/2" thread pressure-tight into the line to be measured via a connecting piece.

Place the sensor tip (hole cap) as deep as possible in the oil (> 40% of the sensor tip length).

To obtain the shortest possible response time, there should be a continuous flow of oil.

8 Modbus

The moisture in oil sensor FO 510 comes with a Modbus RTU Interface. Before commissioning of the sensor, the communication parameters

Modbus ID, Baud rate, Parity und Stop bit

must be set to ensure the communication with the Modbus master. The adjustment can be done either with the CS Instruments PC service software.

Modbus communication default values:

- Modbus ID: 1 (1 -247)
- Baud rate: 19200 bps (1200,2400, 4800, 9600, 19200, 38400 bps)
- Parity: even (none, even, odd)
- Stoppbit: 1 (1,2)

Supported are following function codes:

- Funktionscode 03: Read Holding Register
- Funktionscode 16: Write multiple Register

8.1 Register Mapping measuring values:

Modbus Register	Modbus Adresse	No.of Byte	Data Type	Description	Default Setting	Read Write	Unit /Comment
1001	1000	4	Float	Temperature		R	[°C]
1003	1002	4	Float	Temperature		R	[°F]
1005	1004	4	Float	Water Activity aw		R	
1007	1006	4	Float	xs PPM		R	
1009	1008	4	Float	xs PPM static temperature		R	
1011	1010	4	Float	relative Humidity		R	

for DS400 / DS 500 / Handheld devices - Modbus Sensor Datatyp:

„Data Type R4-32“match with „Data Type Float“

8.2 Registermapping device settings

8.2.1 Modbus Settings (2001...2006)

Modbus Register	Modbus Address	No.of Byte	Data Type	Description	Default Setting	Read Write	Unit /Comment
2001	2000	2	UInt16	Modbus ID	1	R/W	Modbus ID 1...247
2002	2001	2	UInt16	Baudrate	4	R/W	0 = 1200 1 = 2400 2 = 4800 3 = 9600 4 = 19200 5 = 38400
2003	2002	2	UInt16	Parity	1	R/W	0 = none 1 = even 2 = odd
2004	2003	2	UInt16	Number of Stopbits		R/W	0 = 1 Stop Bit 1 = 2 Stop Bit
2005	2004	2	UInt16	Word Order	0xABCD	R/W	0xABCD = Big Endian 0xCDAB = Middle Endian
2006	2005	2	UInt16	Modbus Enabled	FA510: 1 FA515: 0	R/W	0 = Modbus disabled 1 = Modbus Enabled

8.2.2 Analog Scaling Settings (2007...2011)

Modbus Register	Modbus Address	No.of Byte	Data Type	Description	Default Setting	Read Write	Unit /Comment
2007	2006	4	UInt32	Output Value	4	R/W	0 = 4-20mA disabled 1 = Temperature [°C] 2 = Temperature [°F]
2009	2008	4	float	4mA Scale Low	-80	R/W	
2011	2010	4	float	20mA Scale High	20	R/W	

Modbus installation, Modbus settings and further information refer to the manual CS Instruments "**Modbus Installation and Operating Instructions FA 5xx sensors**"

9 Calibration / Adjustment

At the manufacturer

Within the scope of DIN ISO certification, we recommend having the measuring instruments calibrated and, if necessary, adjusted by the manufacturer at regular intervals. The calibration cycles should be based on your internal specifications. Within the scope of DIN ISO certification, we recommend a calibration cycle of one year for the FO 510.

10 Warranty

Defects which are demonstrably due to a factory defect will of course be repaired free of charge. The prerequisite is that you report this defect immediately upon discovery and within the warranty period granted by us. Damage caused by improper use or by non-observance of the operating instructions is excluded from this warranty.

The warranty is also void if the sensor has been opened - unless this is expressly described in the operating instructions for maintenance purposes - or if serial numbers in the device have been changed, damaged, or removed.

The warranty period for FO 510 is 12 months. Unless otherwise defined, 6 months apply to accessories. Warranty services do not cause an extension of the warranty period.

If in addition to the warranty service necessary repairs, adjustments or similar are carried out, the warranty services are free of charge but there is a charge for other services such as transport and packing costs. Other claims, especially those for damage occurring outside the instrument are not included unless responsibility is legally binding.

After-sales service after the warranty time has elapsed

Of course, we are also there for you after the warranty period has expired. In case of malfunctions, please send us your measuring device with a short description of the error. Please also include your telephone number for any queries.

KONFORMITÄTSERKLÄRUNG

DECLARATION OF CONFORMITY

Wir
We CS Instruments GmbH & Co.KG
Gewerbehof 14, 24955 Harsislee

Erklären in alleiniger Verantwortung, dass das Produkt
Declare under our sole responsibility that the product

Ölfeuchte-Sensor FO 510
Moisture in oil sensor FO 510

den Anforderungen folgender Richtlinien entsprechen:

We hereby declare that above mentioned components comply with requirements of the following EU directives:

Elektromagnetische Verträglichkeit Electromagnetic compatibility	2014/30/EUG 2014/30/EC
RoHS (Restriction of certain Hazardous Substances)	2011/65/EC

Angewandte harmonisierte Normen:

Harmonised standards applied:

EMV-Anforderungen EMC requirements	EN EN 55011:2016 + A1:2017 + A11:2020 + A2:2021 EN 61326-1: 2021
--	---

Das Produkt ist mit dem abgebildeten Zeichen gekennzeichnet.
The product is labelled with the indicated mark.



Harsislee, den 14.12.2023

Wolfgang Blessing Geschäftsführer

CS INSTRUMENTS GmbH & Co.KG

Geschäftsstelle Süd / Sales Office South /

Zindelsteiner Str. 15
D-78052 VS-Tannheim

Tel.: +49 (0) 7705 978 99 0

Fax: +49 (0) 7705 978 99 20

Mail: info@cs-instruments.com

Web: <http://www.cs-instruments.com>

Geschäftsstelle Nord / Sales Office North

Gewerbehof 14
D-24955 Harrislee

Tel.: +49 (0) 807 150 0

Fax: +49 (0) 461 807 150 15

Mail: info@cs-instruments.com

Web: <http://www.cs-instruments.com>