



Modbus Installations- und Betriebsanleitung

Intelligenter Bildschirmschreiber

DS 500



I. Vorwort

Sehr geehrter Kunde,

vielen Dank, dass Sie sich für das DS 500 entschieden haben. Bitte lesen Sie vor Montage und Inbetriebnahme diese Installations- und Betriebsanleitung aufmerksam durch und befolgen Sie unsere Hinweise. Nur bei genauer Beachtung der beschriebenen Vorschriften und Hinweise wird die einwandfreie Funktion des DS 500 und ein gefahrloser Betrieb sichergestellt.



CS INSTRUMENTS GmbH & Co. KG

Geschäftsstelle Süd/Sales Office South

Zindelsteiner Str. 15

D-78052 VS-Tannheim

Tel.: +49 (0) 7705 978 99 0

Fax: +49 (0) 7705 978 99 20

Mail: info@cs-instruments.com

Web: <http://www.cs-instruments.com>

Geschäftsstelle Nord/Sales Office North

Gewerbehof 14

D-24955 Harrislee

Tel.: +49 (0) 461 807 150 -0

Fax: +49 (0) 461 807 150 -15

Mail: info@cs-instruments.com

Web: <http://www.cs-instruments.com>

II. Inhaltsverzeichnis

I.	Vorwort	2
II.	Inhaltsverzeichnis.....	3
1	Sicherheitshinweise	5
2	Hinweise	5
2.1	Definitionen und Abkürzungen.....	6
2.2	Referenzen.....	6
3	Technische Daten DS 500	6
3.1	DS500 MODBUS RTU Spezifikation	7
3.2	DS500 MODBUS/ TCP Spezifikation.....	7
3.3	Generelle Modbus Informationen.....	7
3.3.1	Serieller Übertragungs-Mode (RTU).....	8
3.3.2	Ethernet Übertragungsmode	8
4	Installation.....	9
4.1	RS485 Bus Verdrahtung (Modbus RTU) – Anschlussplan DS500V1	9
4.1.1	Einstellung Schalter S4.1.....	9
4.2	RS485 Bus Verdrahtung (Modbus RTU) – Anschlussplan DS500V2.....	10
4.3	Buskabel	11
4.4	Ethernet Verbindung für Modbus/TCP.....	11
5	Modbus RTU Verbindungseinstellungen	12
5.1	Zugriff und Änderung der MODBUS Einstellungen.....	12
6	Modbus TCP Kommunikations-Einstellungen.....	14
7	Modbus Adressierungsmodell.....	15
7.1	Unterstützte Daten Formate	15
7.2	Funktion Code 3 (Read holding register)	16
7.3	Funktion Code 16 (Write multiple registers)	16
8	Modbus Holding Register.....	17
8.1	Basic Values Register	17
8.2	Register der Kanalwerte.....	18
8.2.1	Auslesen von VA5xx Werten	18
8.2.2	Auslesen von Partikelzähler PC400 Werten.....	19
8.2.3	Extended Modbus.....	20
8.2.4	Register der Kanalwerte 1..4 (erste Seite).....	21
8.2.5	Register der Kanalwerte 5..8 (zweite Seite).....	24
8.3	Status register	27
8.3.1	Status register Kanalwerte 1..4.....	27
8.3.2	Status register Kanalwerte 5..8.....	29
8.4	Register Kanal Beschreibung.....	33
8.5	Register Alarmeinstellungen	41
8.6	Register Value extended	44
8.7	Data format test.....	46
8.8	Data Bit description	47
8.9	User Units	49

9 Appendix52
9.1 APPENDIX A - Exception codes 52

1 Sicherheitshinweise



Bitte überprüfen Sie, ob diese Anleitung auch dem Gerätetyp entspricht.

Beachten Sie alle in dieser Bedienungsanleitung gegebenen Hinweise. Sie enthält grundlegende Informationen, die bei Installation, Betrieb und Wartung zu beachten sind. Daher ist diese Bedienungsanleitung unbedingt vor Installation, Inbetriebnahme und Wartung vom Monteur sowie vom zuständigen Betreiber/Fachpersonal zu lesen.

Die Bedienungsanleitung muss jederzeit zugänglich am Einsatzort des DS 500 verfügbar sein.

Zusätzlich zu dieser Betriebsanleitung sind ggf. örtliche bzw. nationale Vorschriften zu beachten.

Bei Unklarheiten oder Fragen zu dieser Anleitung oder dem Gerät setzen Sie sich bitte mit CS Instruments GMBH in Verbindung.



Gefahr!

Netzspannung!

Durch Kontakt mit Netzspannung führenden, nicht isolierten Teilen, besteht die Gefahr eines elektrischen Schlages, welcher schwere Verletzungen und den Tod zur Folge haben kann.

Maßnahmen:

- Bei elektrischer Installation alle geltenden Vorschriften einhalten (z.B. VDE 0100)!
- **Wartungsarbeiten nur im spannungsfreien Zustand durchführen!**
- Alle elektrischen Arbeiten dürfen nur von befugtem Fachpersonal durchgeführt werden.



Gefahr!

Unzulässige Betriebsparameter!

Durch Unter- bzw. Überschreiten von Grenzwerten besteht Gefahr für Menschen und Material, des weiteren können Funktions- und Betriebsstörungen auftreten.

Maßnahmen:

- Stellen Sie sicher, dass das DS 500 nur innerhalb der zulässigen und auf dem Typenschild aufgeführten Grenzwerte betrieben wird.
- Genaues Einhalten der Leistungsdaten des DS 500 im Zusammenhang mit dem Einsatzfall
- Zulässige Lager- und Transporttemperatur nicht überschreiten.

Weitere Sicherheitshinweise:

- Bei Installation und Betrieb sind ebenfalls die geltenden nationalen Bestimmungen und Sicherheitsvorschriften einzuhalten.
- Das DS 500 nicht in explosionsgefährdeten Bereichen einsetzen.

Zusatzhinweise:

- Gerät nicht überhitzen!



Vorsicht!

Fehlfunktionen des DS 500

Durch fehlerhafte Installation und mangelhafte Wartung kann es zu Fehlfunktionen des DS 500 kommen, welche die Anzeige beeinträchtigen und zu Fehlinterpretationen führen können.

2 Hinweise

Diese Bedienungsanleitung beschreibt die Installation und Nutzung des Datenlogger DS500 als ein MODBUS Slave.

Die DS 500 MODBUS Slave Funktionalität ermöglicht dem MODBUS Master die aktuellen und aufgezeichneten Messwerte auszulesen.

Diese Anleitung ist nicht als ein vollständiges MODBUS Tutorial zu verstehen. Es wird vorausgesetzt das der Benutzer allgemeine Kenntnisse bezogen auf das MODBUS RTU Kommunikation-Protokoll besitzt, insbesondere im Hinblick auf MODBUS Master Konfiguration und Bedienung.

Im folgenden Abschnitt werden einige grundsätzliche MODBUS Definitionen erläutert.

2.1 Definitionen und Abkürzungen

CRC	Cyclic Redundancy Check – zyklische Redundanzprüfung Benützt zur Prüfung von Übertragungsfehlern MODBUS RTU. Siehe Anhang
Modbus Master	Ein MODBUS-Gerät, welches in der Lage ist , auf Daten von einem oder mehreren angeschlossenen Modbus-Slaves zugreifen zu können
Modbus Slave	Ein MODBUS-Gerät, welches in der Lage ist auf Anfragen eines MODBUS Master Gerätes zu.
Modbus Adresse	Folgende Notation für die Adressierung der MODBUS RTU Adressen wird verwendet Adressierung: Holding Register 1009 wird angesprochen im Protokoll mit Adresse 1008 MODBUS RTU Register siehe Kapitel 8
PDU	MODBUS protocol Dateneinheit
ADU	MODBUS Applikation Dateneinheit
MBAP	MODBUS Applikation Protocol
RS485	Refers to the 2—wire communication standard defined by EIA/TIA-485. (Physical layer)
Ethernet	

2.2 Referenzen

1. MODBUS over Serial Line Specification and Implementation Guide V1.02
modbus.org 2006 Dec 20
2. MODBUS APPLICATION PROTOCOL SPECIFICATION V1.1b modbus.org
2006 Dec 28
3. MODBUS Messaging on TCP/IP implementation Guide V1.0b
2006 Oct 34
4. DS 500 Bedienungsanleitung

3 Technische Daten DS 500

3.1 DS500 MODBUS RTU Spezifikation

Gerätetyp	Slave
Übertragungsrate	1200,2400, 4800, 9600, 19200, 38400 bps
Geräteadressen Bereich	1...247
Electrical Interface	RS485, 2 wire (Internal Connector X4.1)
Protokoll	RTU
Unterstützte Funktionbefehle	3 lesen holding register
	16 Schreiben multiple register (nur Status Register)
Broadcast	Nein
Standard	Modbus over serial line V1.02

3.2 DS500 MODBUS/ TCP Spezifikation

Gerätetyp	Slave
Geräteadressen Bereich	1...247
Electrical Interface	Ethernet, RJ45
Protocol	MODBUS/TCP
IP Adresse	Erhalten via DHCP oder Statisch
Port	502
Unterstützte Funktionbefehle	3 Lesen holding register
	16 Schreiben multiple register
Standard	Modbus Messaging on TCP/IP Implementation Guide V1.0b

3.3 Generelle Modbus Informationen

Das DS 500 MODBUS Modul erfüllt die Anforderungen entsprechend „Modbus over serial line protocol“ [Reference 1].

Unter anderem bedeutet dies eine Master-Slave-Protokoll auf der Ebene 2 des OSI-Modells

Nur der Master (Master-Gerät) kann explizit Befehle an einen der Slave Geräte senden.

Ein Slave-Gerät überträgt keine Daten ohne Anforderung/Befehl vom Master-Gerät und kommuniziert nicht mit anderen Slave-Geräten im Bus.

MODBUS ist ein „Einzel Master System“ d.h. nur ein Master (Master-Gerät) kann im Bus vorhanden sein.

3.3.1 Serieller Übertragungs-Mode (RTU)

Der DS500 MODBUS unterstützt nur eine serielle Übertragungsart: **RTU Mode**

Der Protokollaufbau definiert den Bit-Inhalt der einzelnen seriellen Übertragungs (Nachricht)-Felder im Bus und legt fest wie die Informationen zusammengestellt und decodiert werden.

Der Protokollaufbau und die seriellen Port Parameter müssen für alle Teilnehmer im MODBUS identisch sein.

RTU mode MODBUS Protokollaufbau siehe Tabelle 1 und ist gültig für beides Anforderung und Antwort

Slave Adresse	Funktion code	Daten	CRC
1 byte	1byte	0 up to 252 byte(s)	2 bytes

Tabelle 1

Weitere Details des MODBUS Protokoll siehe Referenz 1 und 2.

3.3.2 Ethernet Übertragungsmode

Der DS 500 MODBUS Mode unterstützt nur **Modbus/TCP**

Der Protokollaufbau definiert den Bit-Inhalt der einzelnen seriellen Übertragungs (Nachricht)-Felder im Bus und legt fest wie die Informationen zusammengestellt und decodiert werden.

Der Protokollaufbau und die seriellen Port Parameter müssen für alle Teilnehmer im MODBUS identisch sein.

TCP Mode MODBUS Protokollaufbau siehe Tabelle 2 und ist gültig für beides Anforderung und Antwort

Modbus/TCP MBAP Header				PDU	
Transaction Id	Protocol Id	Length	Unit Id	Function Code	Data
2 byte	2 byte	2 byte	1 byte	1byte	0 up to 252 byte (s)

Tabelle 2

4 Installation

4.1 RS485 Bus Verdrahtung (Modbus RTU) – Anschlussplan DS500V1

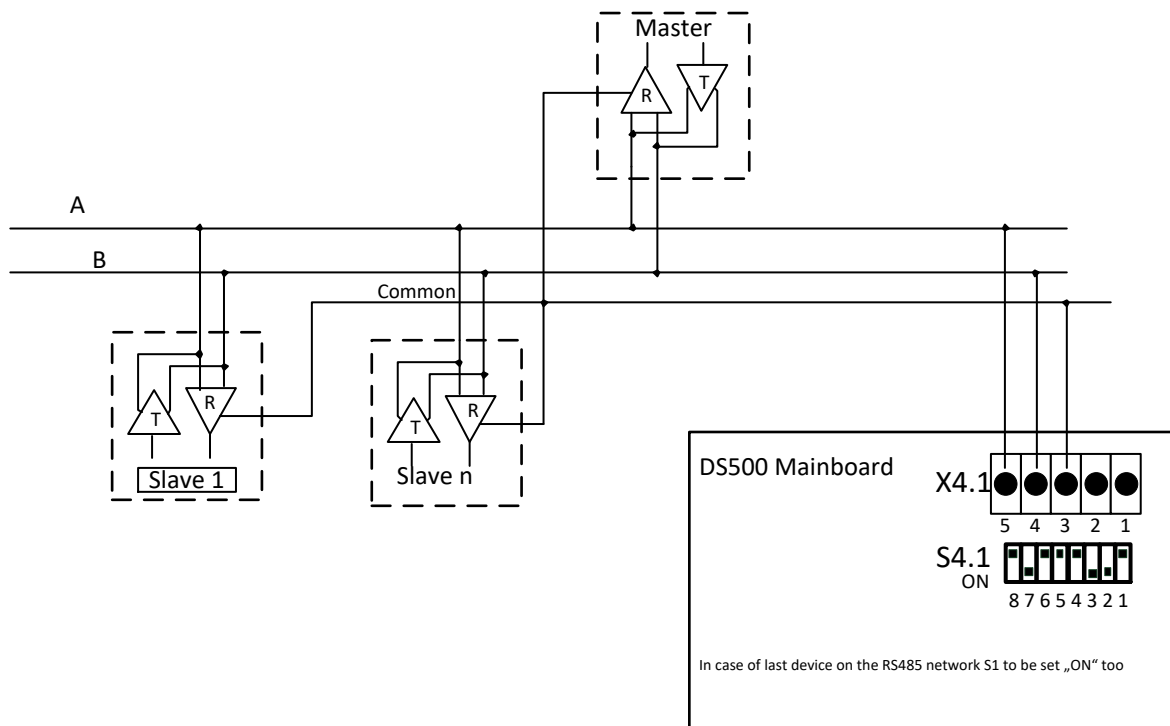
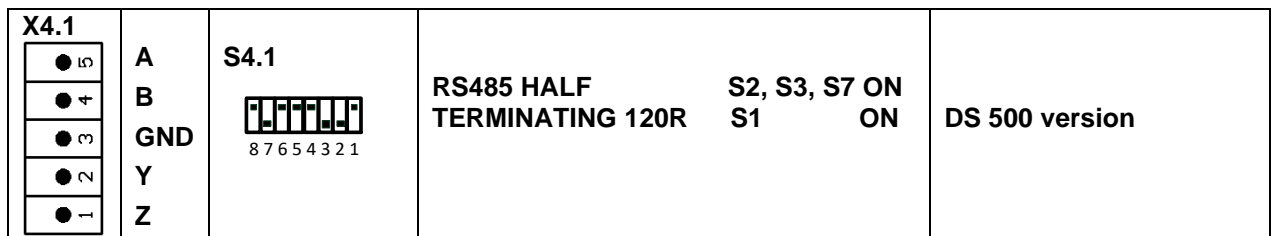
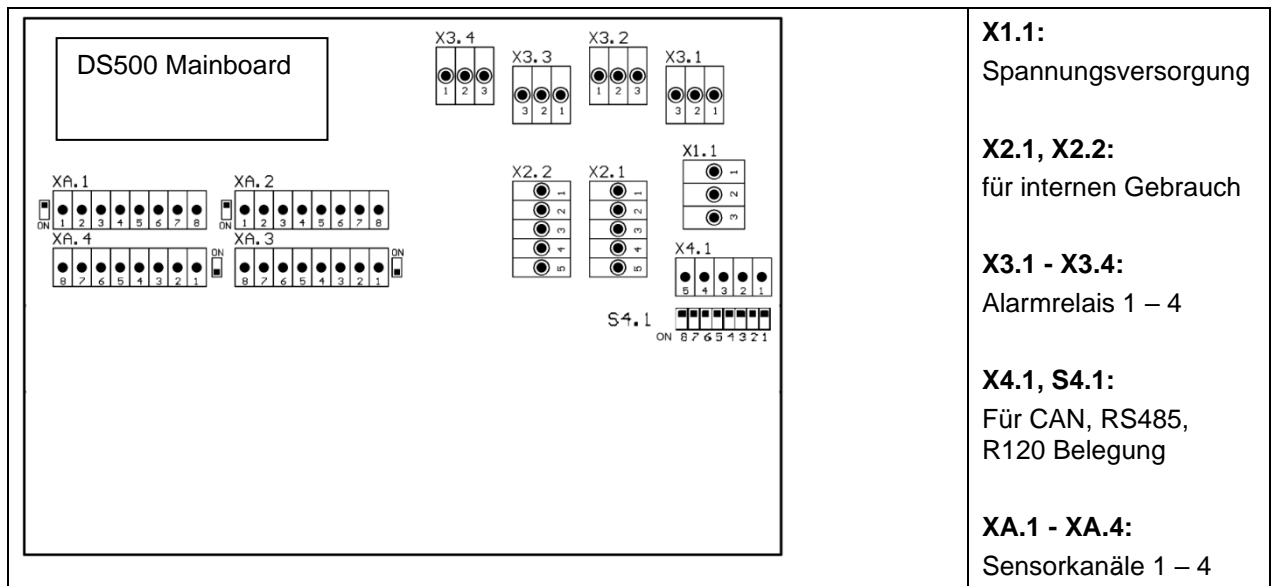

4.1.1 Einstellung Schalter S4.1

S2 → ON
 S3 → ON
 S7 → ON

Bemerkung:

Falls das DS500V1 das letzte Gerät im RS485-Netzwerk ist, sollte der "Netzwerkschalter für den Abschlusswiderstand" auf "ON" stehen.

S1 → ON

4.2 RS485 Bus Verdrahtung (Modbus RTU) – Anschlussplan DS500V2

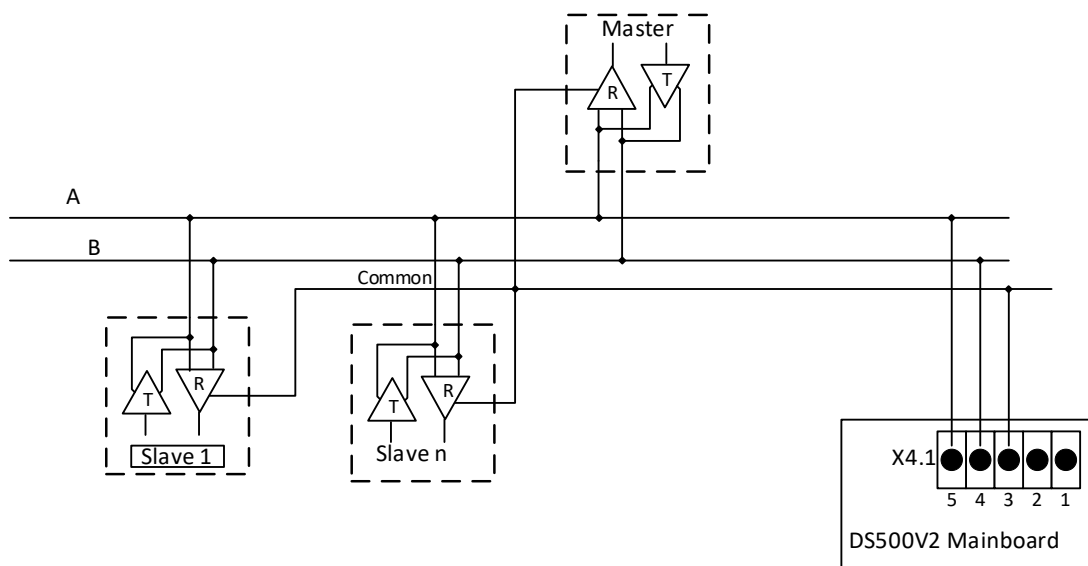
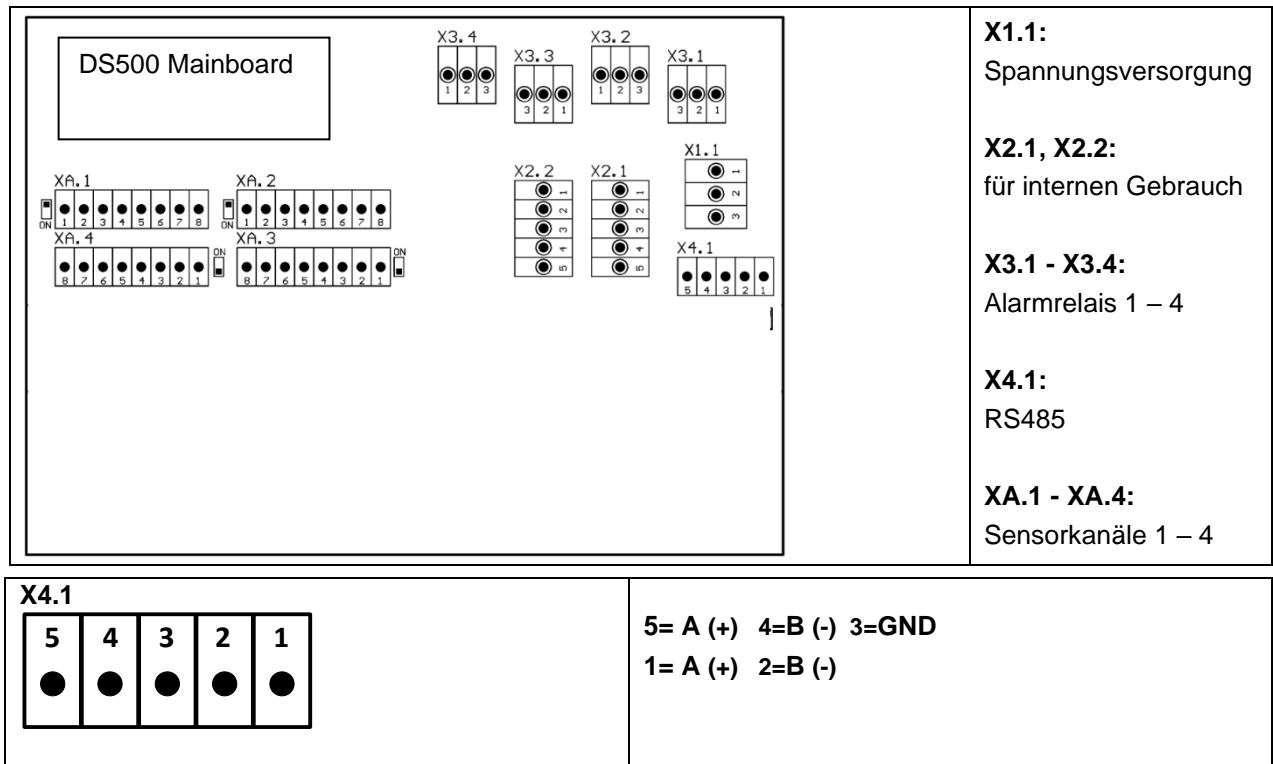

Bemerkung:

Falls das DS500V2 das letzte Gerät im RS485-Netzwerk ist, sollte die die Termierung am DS500V2 per Software eingeschaltet werden.

[Einstellungen](#) → [Geräteeinstellungen](#) → [Modbus Einstellungen](#)



4.3 Buskabel

Nur Kabel entsprechend der EIA485 Empfehlung sollten verwendet werden.

Maximal 64 Geräte sollten an einem Segment angeschlossen sein. Das Kabel sollte min. 20cm von anderen Kabeln entfernt verlegt werden bevorzugt in einem getrennten, leitfähigen und geerdeten Kabelkanal. Es muß sichergestellt werden das kein Potentialunterschied zwischen den einzelnen Geräten am Bus vorhanden ist.

Kable Anforderungen:

Impedanz:	135 -165 Ohm @ 3 to 20 Mhz
Kabelkapazität:	< 30pF/m
Kabeldurchmesser	> 0.64 mm
Kabelquerschnitt	> 0.34 mm ² , conforms to AWG 22
Loop Widerstand	< 110 Ohm pro km
Abschirmung:	Cu-Geflechtschirm oder Geflechtschirm und Abschirmfolie

4.4 Ethernet Verbindung für Modbus/TCP

Für eine einfache Ethernet-Verbindung zu Ihrem Netzwerk ist ein gewöhnlicher RJ45-Ethernet-Anschluß eingebaut.

Kabel:

Ein Ethernet-Kabel Cat5 oder besser sollte verwendet werden.

5 Modbus RTU Verbindungseinstellungen

Für die Kommunikation mit dem Master (Master-Gerät) muß zuerst die korrekte Übertragungsrate, Adresse und das Protokoll eingestellt werden.

5.1 Zugriff und Änderung der MODBUS Einstellungen

Erster Schritt:

Hauptmenü → Einstellungen → Geräteeinstellung → Modbus Einstellungen

Die Einstellungen sind alle passwortgeschützt!

Einstellungen oder Änderungen müssen generell mit **OK** bestätigt werden!



Passwort bei Auslieferung: 0000 (4 x Null).

Es kann bei Bedarf in den *Passwort-Einstellungen* geändert werden.

Das neue Passwort muss zweimal hintereinander eingegeben und mit **OK** bestätigt werden.



Wenn ein falsches Passwort eingegeben wird, erscheint *Passwort eingeben* oder *neues Passwort wiederholen* in roter Schrift.

Wurde das Passwort vergessen kann durch Eingabe des Master Passwords ein neues Passwort vergeben werden.

Bemerkung:

Das Master Passwort wird mit der Gerätedokumentation mitgeliefert.

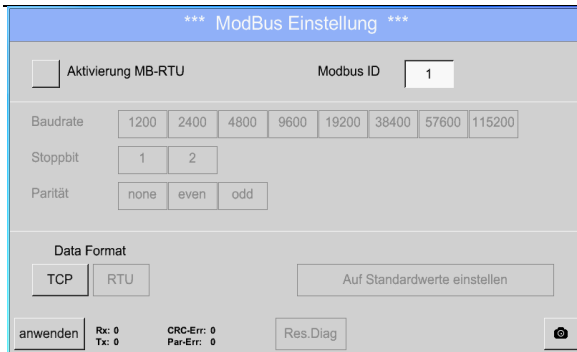

Aktivierung des RTU Modbus mittels setzen des „Aktivierung MB-RTU“ Knopfes

Hier sind die seriellen Übertragungs-parameter *Baudrate, Stopbit, und Paritätsbit* festzulegen.

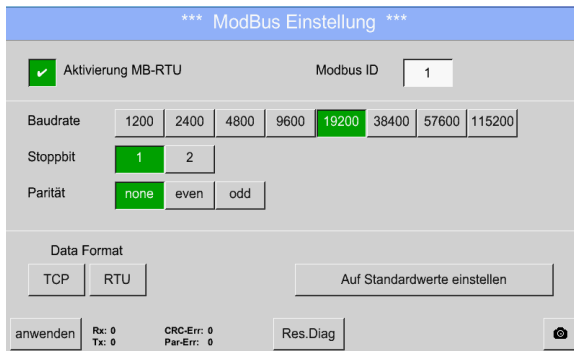

Bestätigung durch *Anwenden*.

Bemerkung: Nur im Falle von Änderungen wird Knopf *Anwenden* dargestellt sonst mit Knopf „Zurück“ ins vorherige Menü.

Mit Betätigen der Taste „Auf Standardwerte“ werden folgende Standardwerte eingestellt.

Standartwerte: Baudrate: 19200bps
Parity: even
Stopbits 1

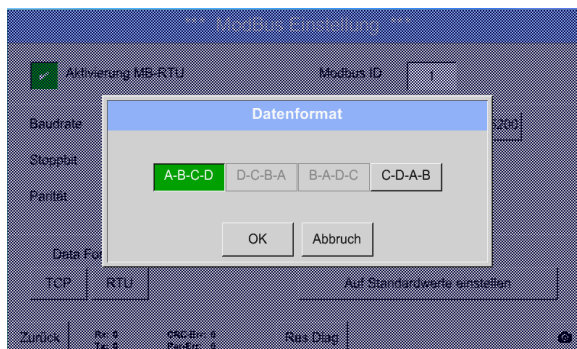

Mit *„Datenformat“* kann die Übertragungsart ABCD (Big Endian) bzw. CDAB (Middle Endian) definiert werden.

Bemerkung:

Es wird nicht empfohlen ohne Prüfung die eingestellte Standard Adresse in einem Netzwerk mit mehreren Slaves zu benutzen. Es ist sicherzustellen dass die Geräte-Adresse nicht schon für ein anderes Slave-Gerät vergeben wurde. Bei einer Mehrfachverwendung der Slave-ID kann es zu einem abnormalen Verhalten des Seriellen Buses führen und die Kommunikation von Master zu allen anderen Slaves ist nicht mehr möglich.

6 Modbus TCP Kommunikations-Einstellungen

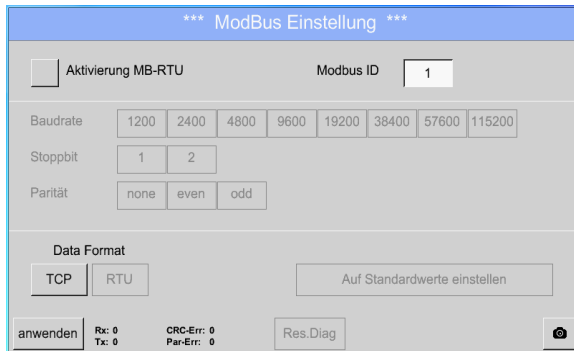

Bei Kommunikation via Modbus TCP ist lediglich die *Modbus Id* zu definieren und mit *Anwenden* bestätigt werden.

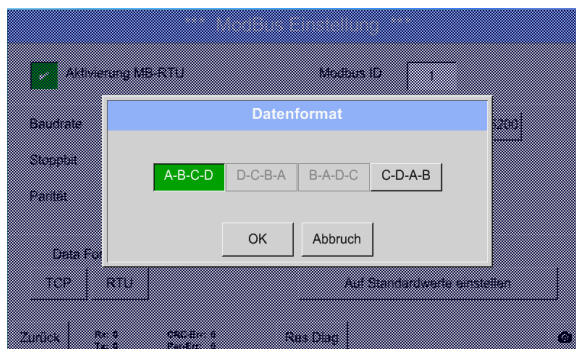

Mit "*Datenformat*" kann die Übertragungsart ABCD (Big Endian) bzw. CDAB (Middle Endian) definiert werden.

7 Modbus Adressierungsmodel

Der DS500 RS485 Modbus erlaubt Lese / Schreib- Zugriffe entsprechend Kapitel 8.
Nicht definierte Register sind nicht adressierbar und werden nicht unterstützt.

Byte Order:

Die Größe eines Modbusregister beträgt 2 Byte. Für einen 32 bit Wert werden vom DS500 zwei Modbusregister ausgelesen. Entsprechend wird für einen 16bit Wert nur ein Register gelesen.

Ausgabeformat DS500:

Single Word

	HByte(A)	LByte(B)
18 =>	00	12
<u>Middle Endian</u>		
Data Order	(B)	(A)
	12	00
<u>Big Endian</u>		
Data Order	(A)	(B)
	00	12

Double Word

	HWord		LWord	
	HByte(A)	LByte(B)	HByte(C)	LByte(D)
29235175522 =>	AE	41	56	52
<u>Middle Endian</u>				
Data Order	(C)	(D)	(A)	(B)
	56	52	AE	41
<u>Big Endian</u>				
Data Order	(A)	(B)	(C)	(D)
	AE	41	56	52

Zum Verifizieren des korrekten Datenformat können die Register 64000 und 64002 ausgelesen werden.

Register 64000 = Long Integer Wert = 1 000 000

Register 64002 = Float Wert = 1 000 000.0

7.1 Unterstützte Daten Formate

UI1 (8b)	= unsigned Integer	=>	0 - 255
I1 (8b)	= signed integer	=>	-128 - 127
UI2 (16b)	= unsigned Integer	=>	0 - 65535
I2 (16b)	= signed integer	=>	-32768 - 32767
UI4 (32b)	= unsigned Integer	=>	0 - 4294967295
I4 (32b)	= signed integer	=>	-2147483648 - 2147483647
R4 (32b)	= Float		

7.2 Funktion Code 3 (Read holding register)

Generelle Ausnahmen:

- Anforderung von weniger als 1 oder mehr als 125 Registers => Exception 3 (Illegal data value)
- Anforderung von mehr als der max. Nachrichtengröße (27 Registern) => Exception 2 (Illegal data address)
- Datenanforderung außerhalb der Register definiert in Kapitel 8 => Exception 2 (Illegal data address)

Applikation Ausnahmen:

- Applikation Fehler => Exception 4 (Slave device error)
- Der Lesebefehl (read command) gibt immer Daten zurück wenn keine Ausnahmen vorliegen.
Nicht korrekte Start / Stopp Sendepausen führen zu Rückgabe (Lesen) von Teildaten.

7.3 Funktion Code 16 (Write multiple registers)

Grundsätzlich können nur Status Register (Register 2001 – 2064) beschrieben werden

Generelle Ausnahmen:

- Schreiben von weniger als 1 oder mehr als 63 Registers => Exception 3 (Illegal data value)
- Wenn die Byte-Anzahl nicht 2x der Registeranzahl entspricht => Exception 3 (Illegal data value)
- Überschreitung der max. Nachrichten Größe (27 Register) => Exception 2 (Illegal data address)
- Schreiben von Daten außerhalb des definierten Registerbereiches in Kapitel 8 => Exception 2 (Illegal data address)

Applikation Ausnahmen :

- Applikation Fehler => Exception 4 (Slave device error)
- Applikation Fehler beinhalten auch schreiben in ReadOnly holding Register

Holes / register alignment:

- Wenn die Start-Adresse nicht im definierten Registerbereich liegt => Exception 2 (Illegal data address)
- Schreiben in nicht definierte Registerbereiche werden ignoriert und keine Ausnahme Fehler angezeigt mit Ausnahme der oben beschriebenen Fällen.

8 Modbus Holding Register

8.1 Basic Values Register

Modbus Register	Modbus Address	No.of Byte	Data Type	Description	Default Setting	Read Write	Comment
1	0	4	Dword	Serial Number	0	R	
3	2	8	String	HostName	0	R	
7	6	4	Dword	HardwareVersion	0	R	<code>sprintf(str,"%u.%02u",hw>>16,hw&0xffff);</code>
9	8	4	Dword	Softwareversion	0	R	<code>sprintf(str,"%u.%02u",sw>>16,sw&0xffff);</code>
11	10	8	Byte(6)	MAC Adress	0	R	Upper 2 bytes are zero
15	14	4	Dword	Calibration Date	0	R	Unix Time
17	16	4	Dword	Runtime Counter	0	R	Value in seconds
19	18	4	Dword	Timet	0	R	Unix Time
21	20	16	String	Brand Name	0	R	
29	28	2	Word	Modbus ID	0	R	Modbus ID
30	29	2	Word	free	0	R	free
31	30	4	Dword	MbRTU Rx Packets OK	0	R	valid RTU telegrams received
33	32	4	Dword	MbRTU Tx Packets	0	R	RTU telegrams transmitted
35	34	4	Dword	MbRTU CRC Errors	0	R	CRC Errors
37	36	4	Dword	MbRtu Parity Errors	0	R	Parity Errors

8.2 Register der Kanalwerte

Wichtig

Anordnung und Datentyp von Werten sind für folgende Sensoren abweichend von der allgemeinen Festlegung.

8.2.1 Auslesen von VA5xx Werten

- Verbrauchswert(e) bei VA5xx Sensoren sind entgegen der Tabelle immer Integerwerte I4(32b)
- Anordnung der Werte erfolgt in folgender Reihe (sind optimiert für ein VA5xx Bidirektional)
 - erste Seite (Wert 1-4) 2x Durchfluß & 2x Verbrauch,
 - zweite Seite (Wert 5-8) Temperatur, Summe Verbrauch, Druck, Geschwindigkeit

Darstellung VA5xx Bidirektional

Record		1..4
Wert 1	▶ Flow	123.30 m³/h
Wert 2	◀ Flow	13.30 m³/h
Wert 3	▶ Consu...	1902003001 m³
Wert 4	◀ Consu...	102003004 m³

Record		5..8
Wert 5	Temp.	28.17 °C
Wert 6	Consumpt.	123.30 m³
Wert 7	Pressure	---- mbar
Wert 8	Velocity	0.00 m/s

Beispiel für Kanal A1:

Wert A1-1 → Register Adr. 1000
Wert A1-2 → Register Adr. 1002
Wert A1-3 → Register Adr. 1004
Wert A1-4 → Register Adr. 1006

Wert A1-5 → Register Adr. 1200
Wert A1-6 → Register Adr. 1202
Wert A1-7 → Register Adr. 1204
Wert A1-8 → Register Adr. 1206

Darstellung VA5xx Standard (ohne Druck)

Aufzeichnen		
Wert 1	<input checked="" type="checkbox"/> Flow	10.31 m³/h
Wert 3	<input type="checkbox"/> Consumpt.	3499 m³
Wert 5	<input type="checkbox"/> Temp.	17.91 °C
Wert 8	<input type="checkbox"/> Velocity	1.59 m/s

Beispiel für Kanal A1:

Wert A1-1 → Register Adr. 1000 (Flow)
Wert A1-3 → Register Adr. 1004 (Verbrauch)
Wert A1-5 → Register Adr. 1200 (Temperatur)
Wert A1-8 → Register Adr. 1206 (Geschwindigkeit)

Darstellung VA5xx (mit Druck)

Aufzeichnen		1..4
Wert 1	<input checked="" type="checkbox"/> Flow	0.00 m³/h
Wert 3	<input type="checkbox"/> Consumpt.	21 m³
Wert 5	<input type="checkbox"/> Temp.	24.46 °C
Wert 7	<input type="checkbox"/> Pressure	5.05 bar

Aufzeichnen		5..8
Wert 8	<input type="checkbox"/> Velocity	0.00 m/s

8.2.2 Auslesen von Partikelzähler PC400 Werten

Hinweis: Abweichungen nur gültig für Software Versionen ab/ > V5.xx

Alle Werte sind entgegen der Tabelle immer Integerwerte UInt4(32b) bzw. UInt16

Seite 1

Seite 2

Wert 1: UInt 32

Wert 2: UInt 32

Wert 3: UInt 32

Wert 3: UInt 16

Wert 5: UInt 32

Wert 6: UInt 32

Wert 7: UInt 32

Wert 8: UInt 16

*** Kanal A2 *** ~ 0.0 V
~ 0 mA

Typ <input type="text" value="PC400"/> <input type="button" value="speichern"/> Name <input type="text" value="PC400"/>	Partikelzähler PC400 Id:1 B:9600 P:E S:1 Timeout:300 msec	
Teile Nr. 5005002 Ser. Nr. 0 Version: V1.18 ...	Sensortyp: <input type="button" value="0.1µ"/> <input type="button" value="0.3µ"/>	
Aufzeichnen <input type="checkbox"/> 1..4 <input type="checkbox"/> Alarm		
<table border="0"> <tr> <td style="color: red; vertical-align: top;"> Wert 1 Wert 2 Wert 3 Wert 4 </td> <td> <input checked="" type="checkbox"/> <input type="checkbox"/> 0.1-0.5µ <input type="checkbox"/> 0 cts/m³ <input type="checkbox"/> <input checked="" type="checkbox"/> <input type="checkbox"/> 0.5-1.0µ <input type="checkbox"/> 0 cts/m³ <input type="checkbox"/> <input checked="" type="checkbox"/> <input type="checkbox"/> 1.0-5.0µ <input type="checkbox"/> 0 cts/m³ <input type="checkbox"/> <input type="checkbox"/> <input type="checkbox"/> LaserPwr <input type="checkbox"/> 99.00 % <input type="checkbox"/> </td> </tr> </table>		Wert 1 Wert 2 Wert 3 Wert 4
Wert 1 Wert 2 Wert 3 Wert 4	<input checked="" type="checkbox"/> <input type="checkbox"/> 0.1-0.5µ <input type="checkbox"/> 0 cts/m³ <input type="checkbox"/> <input checked="" type="checkbox"/> <input type="checkbox"/> 0.5-1.0µ <input type="checkbox"/> 0 cts/m³ <input type="checkbox"/> <input checked="" type="checkbox"/> <input type="checkbox"/> 1.0-5.0µ <input type="checkbox"/> 0 cts/m³ <input type="checkbox"/> <input type="checkbox"/> <input type="checkbox"/> LaserPwr <input type="checkbox"/> 99.00 % <input type="checkbox"/>	
<input type="button" value="Zurück"/> <input type="button" value="☉"/> <input type="button" value="Min/Max"/>		

*** Kanal A2 *** ~ 0.0 V
~ 0 mA

Typ <input type="text" value="PC400"/> <input type="button" value="speichern"/> Name <input type="text" value="PC400"/>	Partikelzähler PC400 Id:1 B:9600 P:E S:1 Timeout:300 msec	
Teile Nr. 5005002 Ser. Nr. 0 Version: V1.18 ...	Sensortyp: <input type="button" value="0.1µ"/> <input type="button" value="0.3µ"/>	
Aufzeichnen <input checked="" type="checkbox"/> 5..8 <input type="checkbox"/> Alarm		
<table border="0"> <tr> <td style="color: red; vertical-align: top;"> Wert 5 Wert 6 Wert 7 Wert 8 </td> <td> <input checked="" type="checkbox"/> <input type="checkbox"/> 0.1-0.5µa <input type="checkbox"/> 0.00 cts/m³ <input type="checkbox"/> <input checked="" type="checkbox"/> <input type="checkbox"/> 0.5-1.0µa <input type="checkbox"/> 0.00 cts/m³ <input type="checkbox"/> <input checked="" type="checkbox"/> <input type="checkbox"/> 1.0-5.0µa <input type="checkbox"/> 0.00 cts/m³ <input type="checkbox"/> <input type="checkbox"/> <input type="checkbox"/> FlowRate <input type="checkbox"/> 42.00 % <input type="checkbox"/> </td> </tr> </table>		Wert 5 Wert 6 Wert 7 Wert 8
Wert 5 Wert 6 Wert 7 Wert 8	<input checked="" type="checkbox"/> <input type="checkbox"/> 0.1-0.5µa <input type="checkbox"/> 0.00 cts/m³ <input type="checkbox"/> <input checked="" type="checkbox"/> <input type="checkbox"/> 0.5-1.0µa <input type="checkbox"/> 0.00 cts/m³ <input type="checkbox"/> <input checked="" type="checkbox"/> <input type="checkbox"/> 1.0-5.0µa <input type="checkbox"/> 0.00 cts/m³ <input type="checkbox"/> <input type="checkbox"/> <input type="checkbox"/> FlowRate <input type="checkbox"/> 42.00 % <input type="checkbox"/>	
<input type="button" value="Zurück"/> <input type="button" value="☉"/> <input type="button" value="Min/Max"/>		

Beispiel; PC400 an Kanal A2

Wert 1:	Register Adr.1008	→ Datentyp UInt32
Wert 2:	Register Adr 1010	→ Datentyp UInt32
Wert 3:	Register Adr 1012	→ Datentyp UInt32
Wert 4:	Register Adr 1014	→ Datentyp UInt16
Wert 5:	Register Adr 1208	→ Datentyp UInt32
Wert 6:	Register Adr 1210	→ Datentyp UInt32
Wert 7:	Register Adr 1212	→ Datentyp UInt32
Wert 8:	Register Adr 1214	→ Datentyp UInt16

8.2.3 Extended Modbus

Wichtig

Für Varianten 4- bzw. 8- Kanales Datenlogger DS500 gibt es die Option „Extended Modbus“. Siehe hierzu die Bedienungsanleitung „DS500 Kapitel 13.3.10“.

Dies erlaubt eine Erweiterung der abzufragenden Werteanzahl für einen Modbus-Sensor von 8 auf 40 zu erhöhen, Anzeige der Werte erfolgt in den Kanälen M1 bis M4.

Je nach Ausführung stehen diese an den Positionen B1-B4 (4Kanal Basis Ausführung) bzw. C1-C4 (8 Kanal Basis Ausführung).

Position “Extended Modbus“

Ausführung 4-Kanal

B1 = M1

B2 = M2

B3 = M3

B4 = M4

Ausführung 8 Kanal

C1 = M1

CB2 = M2

C3 = M3

C4 = M4

M1	--	M2	--	M3	--	M4	--
frei		frei		frei		frei	

Beispiel Abfrage via Modbus

4-Kanal Variante:

Wert 1 von M1 auszulesen : „Channel B1 1st value“ Register 1033 mit Adresse 1032

Wert 1 von M4 auszulesen : „Channel B4 1st value“ Register 1057 mit Adresse 1056

8-Kanal Variante:

Wert 1 von M1 auszulesen : „Channel C1 1st value“ Register 1065 mit Adresse 1064

Wert 1 von M4 auszulesen : „Channel C4 1st value“ Register 1089 mit Adresse 1088

8.2.4 Register der Kanalwerte 1...4 (erste Seite)

Modbus Register	Modbus Address	No.of Byte	Data Type	Description	Default Setting	Read Write	Comment
1001	1000	4	Float/Dword	Channel A1 1st value	0	R	DS500 Data Value *1)
1003	1002	4	Float/Dword	Channel A1 2nd value	0	R	DS500 Data Value *1)
1005	1004	4	Float/Dword	Channel A1 3rd value	0	R	DS500 Data Value *1)
1007	1006	4	Float/Dword	Channel A1 4th value	0	R	DS500 Data Value *1)
1009	1008	4	Float/Dword	Channel A2 1st value	0	R	DS500 Data Value *1)
1011	1010	4	Float/Dword	Channel A2 2nd value	0	R	DS500 Data Value *1)
1013	1012	4	Float/Dword	Channel A2 3rd value	0	R	DS500 Data Value *1)
1015	1014	4	Float/Dword	Channel A2 4th value	0	R	DS500 Data Value *1)
1017	1016	4	Float/Dword	Channel A3 1st value	0	R	DS500 Data Value *1)
1019	1018	4	Float/Dword	Channel A3 2nd value	0	R	DS500 Data Value *1)
1021	1020	4	Float/Dword	Channel A3 3rd value	0	R	DS500 Data Value *1)
1023	1022	4	Float/Dword	Channel A3 4th value	0	R	DS500 Data Value *1)
1025	1024	4	Float/Dword	Channel A4 1st value	0	R	DS500 Data Value *1)
1027	1026	4	Float/Dword	Channel A4 2nd value	0	R	DS500 Data Value *1)
1029	1028	4	Float/Dword	Channel A4 3rd value	0	R	DS500 Data Value *1)
1031	1030	4	Float/Dword	Channel A4 4th value	0	R	DS500 Data Value *1)
1033	1032	4	Float/Dword	Channel B1 1st value	0	R	DS500 Data Value *1)
1035	1034	4	Float/Dword	Channel B1 2nd value	0	R	DS500 Data Value *1)
1037	1036	4	Float/Dword	Channel B1 3rd value	0	R	DS500 Data Value *1)
1039	1038	4	Float/Dword	Channel B1 4th value	0	R	DS500 Data Value *1)
1041	1040	4	Float/Dword	Channel B2 1st value	0	R	DS500 Data Value *1)

Modbus Register	Modbus Address	No.of Byte	Data Type	Description	Default Setting	Read Write	Comment
1043	1042	4	Float/Dword	Channel B2 2nd value	0	R	DS500 Data Value *1)
1045	1044	4	Float/Dword	Channel B2 3rd value	0	R	DS500 Data Value *1)
1047	1046	4	Float/Dword	Channel B2 4th value	0	R	DS500 Data Value *1)
1049	1048	4	Float/Dword	Channel B3 1st value	0	R	DS500 Data Value *1)
1051	1050	4	Float/Dword	Channel B3 2nd value	0	R	DS500 Data Value *1)
1053	1052	4	Float/Dword	Channel B3 3rd value	0	R	DS500 Data Value *1)
1055	1054	4	Float/Dword	Channel B3 4th value	0	R	DS500 Data Value *1)
1057	1056	4	Float/Dword	Channel B4 1st value	0	R	DS500 Data Value *1)
1059	1058	4	Float/Dword	Channel B4 2nd value	0	R	DS500 Data Value *1)
1061	1060	4	Float/Dword	Channel B4 3rd value	0	R	DS500 Data Value *1)
1063	1062	4	Float/Dword	Channel B4 4th value	0	R	DS500 Data Value *1)
1065	1064	4	Float/Dword	Channel C1 1st value	0	R	DS500 Data Value *1)
1067	1066	4	Float/Dword	Channel C1 2nd value	0	R	DS500 Data Value *1)
1069	1068	4	Float/Dword	Channel C1 3rd value	0	R	DS500 Data Value *1)
1071	1070	4	Float/Dword	Channel C1 4th value	0	R	DS500 Data Value *1)
1073	1072	4	Float/Dword	Channel C2 1st value	0	R	DS500 Data Value *1)
1075	1074	4	Float/Dword	Channel C2 2nd value	0	R	DS500 Data Value *1)
1077	1076	4	Float/Dword	Channel C2 3rd value	0	R	DS500 Data Value *1)
1079	1078	4	Float/Dword	Channel C2 4th value	0	R	DS500 Data Value *1)
1081	1080	4	Float/Dword	Channel C3 1st value	0	R	DS500 Data Value *1)
1083	1082	4	Float/Dword	Channel C3 2nd value	0	R	DS500 Data Value *1)
1085	1084	4	Float/Dword	Channel C3 3rd value	0	R	DS500 Data Value *1)
1087	1086	4	Float/Dword	Channel C3 4th value	0	R	DS500 Data Value *1)
Modbus Register	Modbus Address	No.of Byte	Data Type	Description	Default Setting	Read Write	Comment

1089	1088	4	Float/Dword	Channel C4 1st value	0	R	DS500 Data Value *1)
1091	1090	4	Float/Dword	Channel C4 2nd value	0	R	DS500 Data Value *1)
1093	1092	4	Float/Dword	Channel C4 3rd value	0	R	DS500 Data Value *1)
1095	1094	4	Float/Dword	Channel C4 4th value	0	R	DS500 Data Value *1)
1097	1096	4	Float/Dword	Channel V1 1st value	0	R	DS500 Data Value *1)
1099	1098	4	Float/Dword	Channel V1 2nd value	0	R	DS500 Data Value *1)
1101	1100	4	Float/Dword	Channel V1 3rd value	0	R	DS500 Data Value *1)
1103	1102	4	Float/Dword	Channel V1 4th value	0	R	DS500 Data Value *1)
1105	1104	4	Float/Dword	Channel V2 1st value	0	R	DS500 Data Value *1)
1107	1106	4	Float/Dword	Channel V2 2nd value	0	R	DS500 Data Value *1)
1109	1108	4	Float/Dword	Channel V2 3rd value	0	R	DS500 Data Value *1)
1111	1110	4	Float/Dword	Channel V2 4th value	0	R	DS500 Data Value *1)
1113	1112	4	Float/Dword	Channel V3 1st value	0	R	DS500 Data Value *1)
1115	1114	4	Float/Dword	Channel V3 2nd value	0	R	DS500 Data Value *1)
1117	1116	4	Float/Dword	Channel V3 3rd value	0	R	DS500 Data Value *1)
1119	1118	4	Float/Dword	Channel V3 4th value	0	R	DS500 Data Value *1)
1121	1120	4	Float/Dword	Channel V4 1st value	0	R	DS500 Data Value *1)
1123	1122	4	Float/Dword	Channel V4 2nd value	0	R	DS500 Data Value *1)
1125	1124	4	Float/Dword	Channel V4 3rd value	0	R	DS500 Data Value *1)
1127	1126	4	Float/Dword	Channel V4 4th value	0	R	DS500 Data Value *1)

8.2.5 Register der Kanalwerte 5...8 (zweite Seite)

Modbus Register	Modbus Address	No.of Byte	Data Type	Description	Default Setting	Read Write	Comment
1201	1200	4	Float/Dword	Channel A1 5th value	0	R	DS500 Data Value *1)
1203	1202	4	Float/Dword	Channel A1 6th value	0	R	DS500 Data Value *1)
1205	1204	4	Float/Dword	Channel A1 7th value	0	R	DS500 Data Value *1)
1207	1206	4	Float/Dword	Channel A1 8th value	0	R	DS500 Data Value *1)
1209	1208	4	Float/Dword	Channel A2 5th value	0	R	DS500 Data Value *1)
1211	1210	4	Float/Dword	Channel A2 6th value	0	R	DS500 Data Value *1)
1213	1212	4	Float/Dword	Channel A2 7th value	0	R	DS500 Data Value *1)
1215	1214	4	Float/Dword	Channel A2 8th value	0	R	DS500 Data Value *1)
1217	1216	4	Float/Dword	Channel A3 5th value	0	R	DS500 Data Value *1)
1219	1218	4	Float/Dword	Channel A3 6th value	0	R	DS500 Data Value *1)
1221	1220	4	Float/Dword	Channel A3 7th value	0	R	DS500 Data Value *1)
1223	1222	4	Float/Dword	Channel A3 8th value	0	R	DS500 Data Value *1)
1225	1224	4	Float/Dword	Channel A4 5th value	0	R	DS500 Data Value *1)
1227	1226	4	Float/Dword	Channel A4 6th value	0	R	DS500 Data Value *1)
1229	1228	4	Float/Dword	Channel A4 7th value	0	R	DS500 Data Value *1)
1231	1230	4	Float/Dword	Channel A4 8th value	0	R	DS500 Data Value *1)
1233	1232	4	Float/Dword	Channel B1 5th value	0	R	DS500 Data Value *1)
1235	1234	4	Float/Dword	Channel B1 6th value	0	R	DS500 Data Value *1)
1237	1236	4	Float/Dword	Channel B1 7th value	0	R	DS500 Data Value *1)
1239	1238	4	Float/Dword	Channel B1 8th value	0	R	DS500 Data Value *1)
1241	1240	4	Float/Dword	Channel B2 5th value	0	R	DS500 Data Value *1)

Modbus Register	Modbus Address	No.of Byte	Data Type	Description	Default Setting	Read Write	Comment
1243	1242	4	Float/Dword	Channel B2 6th value	0	R	DS500 Data Value *1)
1245	1244	4	Float/Dword	Channel B2 7th value	0	R	DS500 Data Value *1)
1247	1246	4	Float/Dword	Channel B2 4th value	0	R	DS500 Data Value *1)
1249	1248	4	Float/Dword	Channel B3 5th value	0	R	DS500 Data Value *1)
1251	1250	4	Float/Dword	Channel B3 6th value	0	R	DS500 Data Value *1)
1253	1252	4	Float/Dword	Channel B3 7th value	0	R	DS500 Data Value *1)
1255	1254	4	Float/Dword	Channel B3 8th value	0	R	DS500 Data Value *1)
1257	1256	4	Float/Dword	Channel B4 5th value	0	R	DS500 Data Value *1)
1259	1258	4	Float/Dword	Channel B4 6th value	0	R	DS500 Data Value *1)
1261	1260	4	Float/Dword	Channel B4 7th value	0	R	DS500 Data Value *1)
1263	1262	4	Float/Dword	Channel B4 8th value	0	R	DS500 Data Value *1)
1265	1264	4	Float/Dword	Channel C1 5th value	0	R	DS500 Data Value *1)
1267	1266	4	Float/Dword	Channel C1 6th value	0	R	DS500 Data Value *1)
1269	1268	4	Float/Dword	Channel C1 7th value	0	R	DS500 Data Value *1)
1271	1270	4	Float/Dword	Channel C1 8th value	0	R	DS500 Data Value *1)
1273	1272	4	Float/Dword	Channel C2 5th value	0	R	DS500 Data Value *1)
1275	1274	4	Float/Dword	Channel C2 6th value	0	R	DS500 Data Value *1)
1277	1276	4	Float/Dword	Channel C2 7th value	0	R	DS500 Data Value *1)
1279	1278	4	Float/Dword	Channel C2 8th value	0	R	DS500 Data Value *1)
1281	1280	4	Float/Dword	Channel C3 5th value	0	R	DS500 Data Value *1)
1283	1282	4	Float/Dword	Channel C3 6th value	0	R	DS500 Data Value *1)
1285	1284	4	Float/Dword	Channel C3 7th value	0	R	DS500 Data Value *1)
1287	1286	4	Float/Dword	Channel C3 8th value	0	R	DS500 Data Value *1)
Modbus Register	Modbus Address	No.of Byte	Data Type	Description	Default Setting	Read Write	Comment

1289	1288	4	Float/Dword	Channel C4 5th value	0	R	DS500 Data Value *1)
1291	1290	4	Float/Dword	Channel C4 6th value	0	R	DS500 Data Value *1)
1293	1292	4	Float/Dword	Channel C4 7th value	0	R	DS500 Data Value *1)
1295	1294	4	Float/Dword	Channel C4 8th value	0	R	DS500 Data Value *1)
1297	1296	4	Float/Dword	Channel V1 5th value	0	R	DS500 Data Value *1)
1299	1298	4	Float/Dword	Channel V1 6th value	0	R	DS500 Data Value *1)
1301	1300	4	Float/Dword	Channel V1 7th value	0	R	DS500 Data Value *1)
1303	1302	4	Float/Dword	Channel V1 8th value	0	R	DS500 Data Value *1)
1305	1304	4	Float/Dword	Channel V2 5th value	0	R	DS500 Data Value *1)
1307	1306	4	Float/Dword	Channel V2 6th value	0	R	DS500 Data Value *1)
1309	1308	4	Float/Dword	Channel V2 7th value	0	R	DS500 Data Value *1)
1311	1310	4	Float/Dword	Channel V2 8th value	0	R	DS500 Data Value *1)
1313	1312	4	Float/Dword	Channel V3 5th value	0	R	DS500 Data Value *1)
1315	1314	4	Float/Dword	Channel V3 6th value	0	R	DS500 Data Value *1)
1317	1316	4	Float/Dword	Channel V3 7th value	0	R	DS500 Data Value *1)
1319	1318	4	Float/Dword	Channel V3 8th value	0	R	DS500 Data Value *1)
1321	1320	4	Float/Dword	Channel V4 5th value	0	R	DS500 Data Value *1)
1323	1322	4	Float/Dword	Channel V4 6th value	0	R	DS500 Data Value *1)
1325	1324	4	Float/Dword	Channel V4 7th value	0	R	DS500 Data Value *1)
1327	1326	4	Float/Dword	Channel V4 8th value	0	R	DS500 Data Value *1)

8.3 Status register

8.3.1 Status register Kanalwerte 1..4

Modbus Register	Modbus Address	No.of Byte	Data Type	Description	Default Setting	Read Write	Comment
2001	2000	2	word	Channel A1 Value 1 Status	0	R/W	Status *2)
2002	2001	2	word	Channel A1 Value 2 Status	0	R/W	Status *2)
2003	2002	2	word	Channel A1 Value 3 Status	0	R/W	Status *2)
2004	2003	2	word	Channel A1 Value 4 Status	0	R/W	Status *2)
2005	2004	2	word	Channel A2 Value 1 Status	0	R	Status *2)
2006	2005	2	word	Channel A2 Value 2 Status	0	R	Status *2)
2007	2006	2	word	Channel A2 Value 3 Status	0	R	Status *2)
2008	2007	2	word	Channel A2 Value 4 Status	0	R	Status *2)
2009	2008	2	word	Channel A3 Value 1 Status	0	R	Status *2)
2010	2009	2	word	Channel A3 Value 2 Status	0	R	Status *2)
2011	2010	2	word	Channel A3 Value 3 Status	0	R	Status *2)
2012	2011	2	word	Channel A3 Value 4 Status	0	R	Status *2)
2013	2012	2	word	Channel A4 Value 1 Status	0	R	Status *2)
2014	2013	2	word	Channel A4 Value 2 Status	0	R	Status *2)
2015	2014	2	word	Channel A4 Value 3 Status	0	R	Status *2)
2016	2015	2	word	Channel A4 Value 4 Status	0	R	Status *2)
2017	2016	2	word	Channel B1 Value 1 Status	0	R	Status *2)
2018	2017	2	word	Channel B1 Value 2 Status	0	R	Status *2)
2019	2018	2	word	Channel B1 Value 3 Status	0	R	Status *2)
2020	2019	2	word	Channel B1 Value 4 Status	0	R	Status *2)
2021	2020	2	word	Channel B2 Value 1 Status	0	R	Status *2)
Modbus Register	Modbus Address	No.of Byte	Data Type	Description	Default Setting	Read Write	Comment

2022	2021	2	word	Channel B2 Value 2 Status	0	R	Status *2)
2023	2022	2	word	Channel B2 Value 3 Status	0	R	Status *2)
2024	2023	2	word	Channel B2 Value 4 Status	0	R	Status *2)
2025	2024	2	word	Channel B3 Value 1 Status	0	R	Status *2)
2026	2025	2	word	Channel B3 Value 2 Status	0	R	Status *2)
2027	2026	2	word	Channel B3 Value 3 Status	0	R	Status *2)
2028	2027	2	word	Channel B3 Value 4 Status	0	R	Status *2)
2029	2028	2	word	Channel B4 Value 1 Status	0	R	Status *2)
2030	2029	2	word	Channel B4 Value 2 Status	0	R	Status *2)
2031	2030	2	word	Channel B4 Value 3 Status	0	R	Status *2)
2032	2031	2	word	Channel B4 Value 4 Status	0	R	Status *2)
2033	2032	2	word	Channel C1 Value 1 Status	0	R	Status *2)
2034	2033	2	word	Channel C1 Value 2 Status	0	R	Status *2)
2035	2034	2	word	Channel C1 Value 3 Status	0	R	Status *2)
2036	2035	2	word	Channel C1 Value 4 Status	0	R	Status *2)
2037	2036	2	word	Channel C2 Value 1 Status	0	R	Status *2)
2038	2037	2	word	Channel C2 Value 2 Status	0	R	Status *2)
2039	2038	2	word	Channel C2 Value 3 Status	0	R	Status *2)
2040	2039	2	word	Channel C2 Value 4 Status	0	R	Status *2)
2041	2040	2	word	Channel C3 Value 1 Status	0	R	Status *2)
2042	2041	2	word	Channel C3 Value 2 Status	0	R	Status *2)

Modbus Register	Modbus Address	No.of Byte	Data Type	Description	Default Setting	Read Write	Comment
2043	2042	2	word	Channel C3 Value 3 Status	0	R	Status *2)
2044	2043	2	word	Channel C3 Value 4 Status	0	R	Status *2)
2045	2044	2	word	Channel C4 Value 1 Status	0	R	Status *2)
2046	2045	2	word	Channel C4 Value 2 Status	0	R	Status *2)
2047	2046	2	word	Channel C4 Value 3 Status	0	R	Status *2)
2048	2047	2	word	Channel C4 Value 4 Status	0	R	Status *2)
2049	2048	2	word	Channel V1 Value 1 Status	0	R	Status *2)
2050	2049	2	word	Channel V1 Value 2 Status	0	R	Status *2)
2051	2050	2	word	Channel V1 Value 3 Status	0	R	Status *2)
2052	2051	2	word	Channel V1 Value 4 Status	0	R	Status *2)
2053	2052	2	word	Channel V2 Value 1 Status	0	R	Status *2)
2054	2053	2	word	Channel V2 Value 2 Status	0	R	Status *2)
2055	2054	2	word	Channel V2 Value 3 Status	0	R	Status *2)
2056	2055	2	word	Channel V2 Value 4 Status	0	R	Status *2)
2057	2056	2	word	Channel V3 Value 1 Status	0	R	Status *2)
2058	2057	2	word	Channel V3 Value 2 Status	0	R	Status *2)
2059	2058	2	word	Channel V3 Value 3 Status	0	R	Status *2)
2060	2059	2	word	Channel V3 Value 4 Status	0	R	Status *2)
2061	2060	2	word	Channel V4 Value 1 Status	0	R	Status *2)
2062	2061	2	word	Channel V4 Value 2 Status	0	R	Status *2)
2063	2062	2	word	Channel V4 Value 3 Status	0	R	Status *2)
2064	2063	2	word	Channel V4 Value 4 Status	0	R	Status *2)

8.3.2 Status register Kanalwerte 5..8

Modbus Register	Modbus Address	No.of Byte	Data Type	Description	Default Setting	Read Write	Comment
2101	2100	2	word	Channel A1 Value 5 Status	0	R	Status *2)
2102	2101	2	word	Channel A1 Value 6 Status	0	R	Status *2)
2103	2102	2	word	Channel A1 Value 7 Status	0	R	Status *2)
2104	2103	2	word	Channel A1 Value 8 Status	0	R	Status *2)
2105	2104	2	word	Channel A2 Value 5 Status	0	R	Status *2)
2106	2105	2	word	Channel A2 Value 6 Status	0	R	Status *2)
2107	2106	2	word	Channel A2 Value 7 Status	0	R	Status *2)
2108	2107	2	word	Channel A2 Value 8 Status	0	R	Status *2)
2109	2108	2	word	Channel A3 Value 5 Status	0	R	Status *2)
2110	2109	2	word	Channel A3 Value 6 Status	0	R	Status *2)
2111	2110	2	word	Channel A3 Value 7 Status	0	R	Status *2)
2112	2111	2	word	Channel A3 Value 8 Status	0	R	Status *2)
2113	2112	2	word	Channel A4 Value 5 Status	0	R	Status *2)
2114	2113	2	word	Channel A4 Value 6 Status	0	R	Status *2)
2115	2114	2	word	Channel A4 Value 7 Status	0	R	Status *2)
2116	2115	2	word	Channel A4 Value 8 Status	0	R	Status *2)
2117	2116	2	word	Channel B1 Value 5 Status	0	R	Status *2)
2118	2117	2	word	Channel B1 Value 6 Status	0	R	Status *2)
2119	2118	2	word	Channel B1 Value 7 Status	0	R	Status *2)
2120	2119	2	word	Channel B1 Value 8 Status	0	R	Status *2)
2121	2120	2	word	Channel B2 Value 5 Status	0	R	Status *2)

Modbus Register	Modbus Address	No.of Byte	Data Type	Description	Default Setting	Read Write	Comment
2122	2121	2	word	Channel B2 Value 6 Status	0	R	Status *2)
2123	2122	2	word	Channel B2 Value 7 Status	0	R	Status *2)
2124	2123	2	word	Channel B2 Value 8 Status	0	R	Status *2)
2125	2124	2	word	Channel B3 Value 5 Status	0	R	Status *2)
2126	2125	2	word	Channel B3 Value 6 Status	0	R	Status *2)
2127	2126	2	word	Channel B3 Value 7 Status	0	R	Status *2)
2128	2127	2	word	Channel B3 Value 8 Status	0	R	Status *2)
2129	2128	2	word	Channel B4 Value 5 Status	0	R	Status *2)
2130	2129	2	word	Channel B4 Value 6 Status	0	R	Status *2)
2131	2130	2	word	Channel B4 Value 7 Status	0	R	Status *2)
2132	2131	2	word	Channel B4 Value 8 Status	0	R	Status *2)
2133	2132	2	word	Channel C1 Value 5 Status	0	R	Status *2)
2134	2133	2	word	Channel C1 Value 6 Status	0	R	Status *2)
2135	2134	2	word	Channel C1 Value 7 Status	0	R	Status *2)
2136	2135	2	word	Channel C1 Value 8 Status	0	R	Status *2)
2137	2136	2	word	Channel C2 Value 5 Status	0	R	Status *2)
2138	2137	2	word	Channel C2 Value 6 Status	0	R	Status *2)
2139	2138	2	word	Channel C2 Value 7 Status	0	R	Status *2)
2140	2139	2	word	Channel C2 Value 8 Status	0	R	Status *2)
2141	2140	2	word	Channel C3 Value 5 Status	0	R	Status *2)
2142	2141	2	word	Channel C3 Value 6 Status	0	R	Status *2)

Modbus Register	Modbus Address	No.of Byte	Data Type	Description	Default Setting	Read Write	Comment
-----------------	----------------	------------	-----------	-------------	-----------------	------------	---------

2143	2142	2	word	Channel C3 Value 7 Status	0	R	Status *2)
2144	2143	2	word	Channel C3 Value 8 Status	0	R	Status *2)
2145	2144	2	word	Channel C4 Value 5 Status	0	R	Status *2)
2146	2145	2	word	Channel C4 Value 6 Status	0	R	Status *2)
2147	2146	2	word	Channel C4 Value 7 Status	0	R	Status *2)
2148	2147	2	word	Channel C4 Value 8 Status	0	R	Status *2)
2149	2148	2	word	Channel V1 Value 5 Status	0	R	Status *2)
2150	2149	2	word	Channel V1 Value 6 Status	0	R	Status *2)
2151	2150	2	word	Channel V1 Value 7 Status	0	R	Status *2)
2152	2151	2	word	Channel V1 Value 8 Status	0	R	Status *2)
2153	2152	2	word	Channel V2 Value 5 Status	0	R	Status *2)
2154	2153	2	word	Channel V2 Value 6 Status	0	R	Status *2)
2155	2154	2	word	Channel V2 Value 7 Status	0	R	Status *2)
2156	2155	2	word	Channel V2 Value 8 Status	0	R	Status *2)
2157	2156	2	word	Channel V3 Value 5 Status	0	R	Status *2)
2158	2157	2	word	Channel V3 Value 6 Status	0	R	Status *2)
2159	2158	2	word	Channel V3 Value 7 Status	0	R	Status *2)
2160	2159	2	word	Channel V3 Value 8 Status	0	R	Status *2)
2161	2160	2	word	Channel V4 Value 5 Status	0	R	Status *2)
2162	2161	2	word	Channel V4 Value 6 Status	0	R	Status *2)
2163	2162	2	word	Channel V4 Value 7 Status	0	R	Status *2)
2164	2163	2	word	Channel V4 Value 8 Status	0	R	Status *2)

8.4 Register Kanal Beschreibung

Modbus Register	Modbus Address	No.of Byte	Data Type	Description	Default Setting	Read Write	Comment
3001	3000	2	word	Channel A1 sensor type	0	R	Sensor Type *3)
3002	3001	24	string	Channel Name	0	R	Sensor Name *4)
3014	3013	2	word	name/unit index value 1	0	R	Value description *5)
3015	3014	2	word	name/unit index value 2	0	R	Value description *5)
3016	3015	2	word	name/unit index value 3	0	R	Value description *5)
3017	3016	2	word	name/unit index value 4	0	R	Value description *5)
3018	3017	2	word	name/unit index value 5	0	R	Value description *5)
3019	3018	2	word	name/unit index value 6	0	R	Value description *5)
3020	3019	2	word	name/unit index value 7	0	R	Value description *5)
3021	3020	2	word	name/unit index value 8	0	R	Value description *5)
3033	3032	2	word	Channel A2 sensor type	0	R	Sensor Type *3)
3034	3033	24	string	Channel Name	0	R	Sensor Name *4)
3046	3045	2	word	name/unit index value 1	0	R	Value description *5)
3047	3046	2	word	name/unit index value 2	0	R	Value description *5)
3048	3047	2	word	name/unit index value 3	0	R	Value description *5)
3049	3048	2	word	name/unit index value 4	0	R	Value description *5)
3050	3049	2	word	name/unit index value 5	0	R	Value description *5)
3051	3050	2	word	name/unit index value 6	0	R	Value description *5)
3052	3051	2	word	name/unit index value 7	0	R	Value description *5)
3053	3052	2	word	name/unit index value 8	0	R	Value description *5)
3065	3064	2	word	Channel A3 sensor type	0	R	Sensor Type *3)
3066	3065	24	string	Channel Name	0	R	Sensor Name *4)

Modbus Register	Modbus Address	No.of Byte	Data Type	Description	Default Setting	Read Write	Comment
3078	3077	2	word	name/unit index value 1	0	R	Value description *5)
3079	3078	2	word	name/unit index value 2	0	R	Value description *5)
3080	3079	2	word	name/unit index value 3	0	R	Value description *5)
3081	3080	2	word	name/unit index value 4	0	R	Value description *5)
3082	3081	2	word	name/unit index value 5	0	R	Value description *5)
3083	3082	2	word	name/unit index value 6	0	R	Value description *5)
3084	3083	2	word	name/unit index value 7	0	R	Value description *5)
3085	3084	2	word	name/unit index value 8	0	R	Value description *5)
3097	3096	2	word	Channel A4 sensor type	0	R	Sensor Type *3)
3098	3097	24	string	Channel Name	0	R	Sensor Name *4)
3110	3109	2	word	name/unit index value 1	0	R	Value description *5)
3111	3110	2	word	name/unit index value 2	0	R	Value description *5)
3112	3111	2	word	name/unit index value 3	0	R	Value description *5)
3113	3112	2	word	name/unit index value 4	0	R	Value description *5)
3114	3113	2	word	name/unit index value 5	0	R	Value description *5)
3115	3114	2	word	name/unit index value 6	0	R	Value description *5)
3116	3115	2	word	name/unit index value 7	0	R	Value description *5)
3117	3116	2	word	name/unit index value 8	0	R	Value description *5)
3129	3128	2	word	Channel B1 sensor type	0	R	Sensor Type *3)
3130	3129	24	string	Channel Name	0	R	Sensor Name *4)
3142	3141	2	word	name/unit index value 1	0	R	Value description *5)
3143	3142	2	word	name/unit index value 2	0	R	Value description *5)

Modbus Register	Modbus Address	No.of Byte	Data Type	Description	Default Setting	Read Write	Comment
3144	3143	2	word	name/unit index value 3	0	R	Value description *5)
3145	3144	2	word	name/unit index value 4	0	R	Value description *5)
3146	3145	2	word	name/unit index value 5	0	R	Value description *5)
3147	3146	2	word	name/unit index value 6	0	R	Value description *5)
3148	3147	2	word	name/unit index value 7	0	R	Value description *5)
3149	3148	2	word	name/unit index value 8	0	R	Value description *5)
3161	3160	2	word	Channel B2 sensor type	0	R	Sensor Type *3)
3162	3161	24	string	Channel Name	0	R	Sensor Name *4)
3174	3173	2	word	name/unit index value 1	0	R	Value description *5)
3175	3174	2	word	name/unit index value 2	0	R	Value description *5)
3176	3175	2	word	name/unit index value 3	0	R	Value description *5)
3177	3176	2	word	name/unit index value 4	0	R	Value description *5)
3178	3177	2	word	name/unit index value 5	0	R	Value description *5)
3179	3178	2	word	name/unit index value 6	0	R	Value description *5)
3180	3179	2	word	name/unit index value 7	0	R	Value description *5)
3181	3180	2	word	name/unit index value 8	0	R	Value description *5)
3193	3192	2	word	Channel B3 sensor type	0	R	Sensor Type *3)
3194	3193	24	string	Channel Name	0	R	Sensor Name *4)
3206	3205	2	word	name/unit index value 1	0	R	Value description *5)
3207	3206	2	word	name/unit index value 2	0	R	Value description *5)
3208	3207	2	word	name/unit index value 3	0	R	Value description *5)

Modbus Register	Modbus Address	No.of Byte	Data Type	Description	Default Setting	Read Write	Comment
3209	3208	2	word	name/unit index value 4	0	R	Value description *5)
3210	3209	2	word	name/unit index value 5	0	R	Value description *5)
3211	3210	2	word	name/unit index value 6	0	R	Value description *5)
3212	3211	2	word	name/unit index value 7	0	R	Value description *5)
3213	3212	2	word	name/unit index value 8	0	R	Value description *5)
3225	3224	2	word	Channel B4 sensor type	0	R	Sensor Type *3)
3226	3225	24	string	Channel Name	0	R	Sensor Name *4)
3238	3237	2	word	name/unit index value 1	0	R	Value description *5)
3239	3238	2	word	name/unit index value 2	0	R	Value description *5)
3240	3239	2	word	name/unit index value 3	0	R	Value description *5)
3241	3240	2	word	name/unit index value 4	0	R	Value description *5)
3242	3241	2	word	name/unit index value 5	0	R	Value description *5)
3243	3242	2	word	name/unit index value 6	0	R	Value description *5)
3244	3243	2	word	name/unit index value 7	0	R	Value description *5)
3245	3244	2	word	name/unit index value 8	0	R	Value description *5)
3257	3256	2	word	Channel C1 sensor type	0	R	Sensor Type *3)
3258	3257	24	string	Channel Name	0	R	Sensor Name *4)
3270	3269	2	word	name/unit index value 1	0	R	Value description *5)
3271	3270	2	word	name/unit index value 2	0	R	Value description *5)
3272	3271	2	word	name/unit index value 3	0	R	Value description *5)
3273	3272	2	word	name/unit index value 4	0	R	Value description *5)

Modbus Register	Modbus Address	No.of Byte	Data Type	Description	Default Setting	Read Write	Comment
3274	3273	2	word	name/unit index value 5	0	R	Value description *5)
3275	3274	2	word	name/unit index value 6	0	R	Value description *5)
3276	3275	2	word	name/unit index value 7	0	R	Value description *5)
3277	3276	2	word	name/unit index value 8	0	R	Value description *5)
3289	3288	2	word	Channel C2 sensor type	0	R	Sensor Type *3)
3290	3289	24	string	Channel Name	0	R	Sensor Name *4)
3302	3301	2	word	name/unit index value 1	0	R	Value description *5)
3303	3302	2	word	name/unit index value 2	0	R	Value description *5)
3304	3303	2	word	name/unit index value 3	0	R	Value description *5)
3305	3304	2	word	name/unit index value 4	0	R	Value description *5)
3306	3305	2	word	name/unit index value 5	0	R	Value description *5)
3307	3306	2	word	name/unit index value 6	0	R	Value description *5)
3308	3307	2	word	name/unit index value 7	0	R	Value description *5)
3309	3308	2	word	name/unit index value 8	0	R	Value description *5)
3321	3320	2	word	Channel C3 sensor type	0	R	Sensor Type *3)
3322	3321	24	string	Channel Name	0	R	Sensor Name *4)
3334	3333	2	word	name/unit index value 1	0	R	Value description *5)
3335	3334	2	word	name/unit index value 2	0	R	Value description *5)
3336	3335	2	word	name/unit index value 3	0	R	Value description *5)
3337	3336	2	word	name/unit index value 4	0	R	Value description *5)
3338	3337	2	word	name/unit index value 5	0	R	Value description *5)

Modbus Register	Modbus Address	No.of Byte	Data Type	Description	Default Setting	Read Write	Comment
3339	3338	2	word	name/unit index value 6	0	R	Value description *5)
3340	3339	2	word	name/unit index value 7	0	R	Value description *5)
3341	3340	2	word	name/unit index value 8	0	R	Value description *5)
3353	3352	2	word	Channel C4 sensor type	0	R	Sensor Type *3)
3354	3353	24	string	Channel Name	0	R	Sensor Name *4)
3366	3365	2	word	name/unit index value 1	0	R	Value description *5)
3367	3366	2	word	name/unit index value 2	0	R	Value description *5)
3368	3367	2	word	name/unit index value 3	0	R	Value description *5)
3369	3368	2	word	name/unit index value 4	0	R	Value description *5)
3370	3369	2	word	name/unit index value 5	0	R	Value description *5)
3371	3370	2	word	name/unit index value 6	0	R	Value description *5)
3372	3371	2	word	name/unit index value 7	0	R	Value description *5)
3373	3372	2	word	name/unit index value 8	0	R	Value description *5)
3385	3384	2	word	Channel V1 sensor type	0	R	Sensor Type *3)
3386	3385	24	string	Channel Name	0	R	Sensor Name *4)
3398	3397	2	word	name/unit index value 1	0	R	Value description *5)
3399	3398	2	word	name/unit index value 2	0	R	Value description *5)
3400	3399	2	word	name/unit index value 3	0	R	Value description *5)
3401	3400	2	word	name/unit index value 4	0	R	Value description *5)
3402	3401	2	word	name/unit index value 5	0	R	Value description *5)
3403	3402	2	word	name/unit index value 6	0	R	Value description *5)

Modbus Register	Modbus Address	No.of Byte	Data Type	Description	Default Setting	Read Write	Comment
3404	3403	2	word	name/unit index value 7	0	R	Value description *5)
3405	3404	2	word	name/unit index value 8	0	R	Value description *5)
3417	3416	2	word	Channel V2 sensor type	0	R	Sensor Type *3)
3418	3417	24	string	Channel Name	0	R	Sensor Name *4)
3430	3429	2	word	name/unit index value 1	0	R	Value description *5)
3431	3430	2	word	name/unit index value 2	0	R	Value description *5)
3432	3431	2	word	name/unit index value 3	0	R	Value description *5)
3433	3432	2	word	name/unit index value 4	0	R	Value description *5)
3434	3433	2	word	name/unit index value 5	0	R	Value description *5)
3435	3434	2	word	name/unit index value 6	0	R	Value description *5)
3436	3435	2	word	name/unit index value 7	0	R	Value description *5)
3437	3436	2	word	name/unit index value 8	0	R	Value description *5)
3449	3448	2	word	Channel V3 sensor type	0	R	Sensor Type *3)
3450	3449	24	string	Channel Name	0	R	Sensor Name *4)
3462	3461	2	word	name/unit index value 1	0	R	Value description *5)
3463	3462	2	word	name/unit index value 2	0	R	Value description *5)
3464	3463	2	word	name/unit index value 3	0	R	Value description *5)
3465	3464	2	word	name/unit index value 4	0	R	Value description *5)
3466	3465	2	word	name/unit index value 5	0	R	Value description *5)
3467	3466	2	word	name/unit index value 6	0	R	Value description *5)
3468	3467	2	word	name/unit index value 7	0	R	Value description *5)

Modbus Register	Modbus Address	No.of Byte	Data Type	Description	Default Setting	Read Write	Comment
3469	3468	2	word	name/unit index value 8	0	R	Value description *5)
3481	3480	2	word	Channel V4 sensor type	0	R	Sensor Type *3)
3482	3481	24	string	Channel Name	0	R	Sensor Name *4)
3494	3493	2	word	name/unit index value 1	0	R	Value description *5)
3495	3494	2	word	name/unit index value 2	0	R	Value description *5)
3496	3495	2	word	name/unit index value 3	0	R	Value description *5)
3497	3496	2	word	name/unit index value 4	0	R	Value description *5)
3498	3497	2	word	name/unit index value 5	0	R	Value description *5)
3499	3498	2	word	name/unit index value 6	0	R	Value description *5)
3500	3499	2	word	name/unit index value 7	0	R	Value description *5)
3501	3500	2	word	name/unit index value 8	0	R	Value description *5)

32 registers = 64 byte for one channel (8 values); actually 21 registers used per channel

8.5 Register Alarmeinstellungen

Modbus Register	Modbus Address	No.of Byte	Data Type	Description	Default Setting	Read Write	Comment
4001	4000	2	word	Channel / Value	0	R	Alarmsettings #1 *6)
4002	4001	2	word	Relais	0	R	relais setting *7)
4003	4002	4	float	upper warning value	0	R	
4005	4004	4	float	Hysteresis for above	0	R	
4007	4006	4	float	upper alarm value	0	R	
4009	4008	4	float	Hysteresis for above	0	R	
4011	4010	4	float	lower warning value	0	R	
4013	4012	4	float	Hysteresis for above	0	R	
4015	4014	4	float	lower alarm value	0	R	
4017	4016	4	float	Hysteresis for above	0	R	
4019	4018	4	float	Reserved			
4021	4020	2	word	Channel / Value	0	R	Alarmsettings #2 *6)
4022	4021	2	word	Relais	0	R	relais setting *7)
4023	4022	4	float	upper warning value	0	R	
4025	4024	4	float	Hysteresis for above	0	R	
4027	4026	4	float	upper alarm value	0	R	
4029	4028	4	float	Hysteresis for above	0	R	
4031	4030	4	float	lower warning value	0	R	
4033	4032	4	float	Hysteresis for above	0	R	
4035	4034	4	float	lower alarm value	0	R	
4037	4036	4	float	Hysteresis for above	0	R	
4039	4038	4	float	Reserved			

Modbus Register	Modbus Address	No.of Byte	Data Type	Description	Default Setting	Read Write	Comment
4041	4040	20	-	Channel / Value	0	R	Alarmsettings #3
4061	4060	20	-	Channel / Value	0	R	Alarmsettings #4
4081	4080	20	-	Channel / Value	0	R	Alarmsettings #5
4101	4100	20	-	Channel / Value	0	R	Alarmsettings #6
4121	4120	20	-	Channel / Value	0	R	Alarmsettings #7
4141	4140	20	-	Channel / Value	0	R	Alarmsettings #8
4161	4160	20	-	Channel / Value	0	R	Alarmsettings #9
4181	4180	20	-	Channel / Value	0	R	Alarmsettings #10
4201	4200	20	-	Channel / Value	0	R	Alarmsettings #11
4221	4220	20	-	Channel / Value	0	R	Alarmsettings #12
4241	4240	20	-	Channel / Value	0	R	Alarmsettings #13
4261	4260	20	-	Channel / Value	0	R	Alarmsettings #14
4281	4280	20	-	Channel / Value	0	R	Alarmsettings #15
4301	4300	20	-	Channel / Value	0	R	Alarmsettings #16
4321	4320	20	-	Channel / Value	0	R	Alarmsettings #17
4341	4340	20	-	Channel / Value	0	R	Alarmsettings #18
4361	4360	20	-	Channel / Value	0	R	Alarmsettings #19
4381	4380	20	-	Channel / Value	0	R	Alarmsettings #20
4401	4400	20	-	Channel / Value	0	R	Alarmsettings #21
4421	4420	20	-	Channel / Value	0	R	Alarmsettings #22
4441	4440	20	-	Channel / Value	0	R	Alarmsettings #23
4461	4460	20	-	Channel / Value	0	R	Alarmsettings #24

Modbus Register	Modbus Address	No.of Byte	Data Type	Description	Default Setting	Read Write	Comment
4481	4480	20	-	Channel / Value	0	R	Alarmsettings #25
4501	4500	20	-	Channel / Value	0	R	Alarmsettings #26
4521	4520	20	-	Channel / Value	0	R	Alarmsettings #27
4541	4540	20	-	Channel / Value	0	R	Alarmsettings #28
4561	4560	20	-	Channel / Value	0	R	Alarmsettings #29
4581	4580	20	-	Channel / Value	0	R	Alarmsettings #30
4601	4600	20	-	Channel / Value	0	R	Alarmsettings #31
4621	4620	20	-	Channel / Value	0	R	Alarmsettings #32

8.6 Register Value extended

Modbus Register	Modbus Address	No.of Byte	Data Type	Description	Default Setting	Read Write	Comment
10001	10000	12	string	A1a Value Name long	0	R	string max 10 character
10007	10006	6	string	A1a Value Name short	0	R	string max 3 character
10010	10009	2	word	A1a Value Resolution	0	R	0.5
10011	10010	30	free	A1a future use	0	R	
10026	10025	12	string	A1b Value Name long	0	R	string max 10 character
10032	10031	6	string	A1b Value Name short	0	R	string max 3 character
10035	10034	2	word	A1b Value Resolution	0	R	0.5
10036	10035	30	free	A1b future use	0	R	
10051	10050	12	string	A1c Value Name long	0	R	string max 10 character
10057	10056	6	string	A1c Value Name short	0	R	string max 3 character
10060	10059	2	word	A1c Value Resolution	0	R	0.5
10061	10060	30	free	A1c future use	0	R	
10076	10075	12	string	A1d Value Name long	0	R	string max 10 character
10082	10081	6	string	A1d Value Name short	0	R	string max 3 character
10085	10084	2	word	A1d Value Resolution	0	R	0.5
10086	10085	30	free	A1d future use	0	R	
10101	10100	12	string	A1e Value Name long	0	R	string max 10 character
10107	10106	6	string	A1e Value Name short	0	R	string max 3 character
10110	10109	2	word	A1e Value Resolution	0	R	0.5
10111	10110	30	free	A1e future use	0	R	
10126	10125	12	string	A1f Value Name long	0	R	string max 10 character
10132	10131	6	string	A1f Value Name short	0	R	string max 3 character

Modbus Register	Modbus Address	No.of Byte	Data Type	Description	Default Setting	Read Write	Comment
10135	10134	2	word	A1f Value Resolution	0	R	0..5
10136	10135	30	free	A1f future use	0	R	
10151	10150	12	string	A1g Value Name long	0	R	string max 10 character
10157	10156	6	string	A1g Value Name short	0	R	string max 3 character
10160	10159	2	word	A1g Value Resolution	0	R	0..5
10161	10160	30	free	A1g future use	0	R	
10176	10175	12	string	A1h Value Name long	0	R	string max 10 character
10182	10181	6	string	A1h Value Name short	0	R	string max 3 character
10185	10184	2	word	A1h Value Resolution	0	R	0..5
10186	10185	30	free	A1h future use	0	R	
10201	10200	8*25	xxx	Channel A2	0	R	similar to channel A1
10401	10400	8*25	xxx	Channel A3	0	R	similar to channel A1
10601	10600	8*25	xxx	Channel A4	0	R	similar to channel A1
10801	10800	8*25	xxx	Channel B1	0	R	similar to channel A1
11001	11000	8*25	xxx	Channel B2	0	R	similar to channel A1
11201	11200	8*25	xxx	Channel B3	0	R	similar to channel A1
11401	11400	8*25	xxx	Channel B4	0	R	similar to channel A1
11601	11600	8*25	xxx	Channel C1	0	R	similar to channel A1
11801	11800	8*25	xxx	Channel C2	0	R	similar to channel A1
12001	12000	8*25	xxx	Channel C3	0	R	similar to channel A1
12201	12200	8*25	xxx	Channel C4	0	R	similar to channel A1

Modbus Register	Modbus Address	No.of Byte	Data Type	Description	Default Setting	Read Write	Comment
11401	11400	8*25	xxx	Channel B4	0	R	similar to channel A1
11601	11600	8*25	xxx	Channel C1	0	R	similar to channel A1
11801	11800	8*25	xxx	Channel C2	0	R	similar to channel A1
12001	12000	8*25	xxx	Channel C3	0	R	similar to channel A1
12201	12200	8*25	xxx	Channel C4	0	R	similar to channel A1
12401	12400	8*25	xxx	Channel V1	0	R	similar to channel A1
12601	12600	8*25	xxx	Channel V2	0	R	similar to channel A1
12801	12800	8*25	xxx	Channel V3	0	R	similar to channel A1
13001	13000	8*25	xxx	Channel V4	0	R	similar to channel A1

8.7 Data format test

Modbus Register	Modbus Address	No.of Byte	Data Type	Description	Default Setting	Read Write	Comment
64001	64000	4	Dword	1000000	x	R	format test for Dword
64003	64002	4	float	1000000.0	x	R	format test for float

8.8 Data Bit description

*1)		Data Value				
		Format (Dword / Float) depends on Value Description Bit 15			see below *5)	
		Position of Dezimal Point depends on Value Description Bit 14..12			see below *5)	
*2)		Data Status				
Write 1 to these bits clears Status	Bit	15	Sensor changed		different sensor	
	Bit	14	Sensor setting changed		mayor parameter changed	
	Bit	13	Sensor Alarm settings changed		Alarm settings changed	
	Bit	12	Sensor name changed		minor change	
	Bit	11	Lower Alarm active			
	Bit	10	Lower Warning active			
	Bit	9	Upper Alarm active			
	Bit	8	Upper Warning active			
	Bit	7	tbd		Value status	
	Bit	6	Channel Error		Value status	
	Bit	5	Value Error		Value status	
	Bit	4	out of range		Value status	
	Bit	3	Stopped		Value status	
	Bit	2	UVP status		Value status	
	Bit	1	OCP status		Value status	
	Bit	0	Channel Disconnected		Value status	
*3)		Sensor Type				
	Bit	15..8	Sensor Basic type		0..255	0 = no sensor
	Bit	7..0	Sensor Subtype		0..255	
*4)		Channel Name				
	Name coding in UTF8 (max 24 Byte)					
*5)		Value description				
	Bit	15	1 = Dword , 0 = float		0,1	
	Bit	14..12	position of dezimal point		0..7	
	Bit	11..7	index of value name		0..31	
	Bit	6..0	index of unit name		0..127	0 = value not used

*6)		Alarm Channel / Value				
		Bit	11	lower Alarm used		
		Bit	10	lower Warning used		
		Bit	9	upper Alarm used		
		Bit	8	upper Warning used		
		Bit	7	Alarm used (valid)		Alarm settings used
		Bit	6..4	Value Nr	0..7	
		Bit	3..0	Channel	0..11	

*7)		Alarm Relais				
		Bit	15	Lower alarm Relais 4 used		
		Bit	14	Lower alarm Relais 3 used		
		Bit	13	Lower alarm Relais 2 used		
		Bit	12	Lower alarm Relais 1 used		
		Bit	11	Lower warning Relais 4 used		
		Bit	10	Lower warning Relais 3 used		
		Bit	9	Lower warning Relais 2 used		
		Bit	8	Lower warning Relais 1 used		
		Bit	7	Upper alarm Relais 4 used		
		Bit	6	Upper alarm Relais 3 used		
		Bit	5	Upper alarm Relais 2 used		
		Bit	4	Upper alarm Relais 1 used		
		Bit	3	Upper warning Relais 4 used		
		Bit	2	Upper warning Relais 3 used		
		Bit	1	Upper warning Relais 2 used		
		Bit	0	Upper warning Relais 1 used		

8.9 User Units

Modbus Register	Modbus Address	No.of Byte	Data Type	Description	Default Setting	Read Write	Comment
14001	14000	10	string	Unit Name 1	°C	R	UTF8 string (max 10 character)
14009	14008	10	string	Unit Name 2	°F	R	UTF8 string (max 10 character)
14017	14016	10	string	Unit Name 3	%RH	R	UTF8 string (max 10 character)
14025	14024	10	string	Unit Name 4	°Ctd	R	UTF8 string (max 10 character)
14033	14032	10	string	Unit Name 5	°Ftd	R	UTF8 string (max 10 character)
14041	14040	10	string	Unit Name 6	mg/kg	R	UTF8 string (max 10 character)
14049	14048	10	string	Unit Name 7	mg/m ³	R	UTF8 string (max 10 character)
14057	14056	10	string	Unit Name 8	g/kg	R	UTF8 string (max 10 character)
14065	14064	10	string	Unit Name 9	g/m ³	R	UTF8 string (max 10 character)
14073	14072	10	string	Unit Name 10	m/s	R	UTF8 string (max 10 character)
14081	14080	10	string	Unit Name 11	Ft/min	R	UTF8 string (max 10 character)
14089	14088	10	string	Unit Name 12	Nm/s	R	UTF8 string (max 10 character)
14097	14096	10	string	Unit Name 13	Nft/min	R	UTF8 string (max 10 character)
14105	14104	10	string	Unit Name 14	m ³ /h	R	UTF8 string (max 10 character)
14113	14112	10	string	Unit Name 15	m ³ /min	R	UTF8 string (max 10 character)
14121	14120	10	string	Unit Name 16	ltr/min	R	UTF8 string (max 10 character)
14129	14128	10	string	Unit Name 17	ltr/s	R	UTF8 string (max 10 character)
14137	14136	10	string	Unit Name 18	cfm	R	UTF8 string (max 10 character)
14145	14144	10	string	Unit Name 19	Nm ³ /h	R	UTF8 string (max 10 character)
14153	14152	10	string	Unit Name 20	Nm ³ /min	R	UTF8 string (max 10 character)
14161	14160	10	string	Unit Name 21	NI/min	R	UTF8 string (max 10 character)
14169	14168	10	string	Unit Name 22	NI/min	R	UTF8 string (max 10 character)

Modbus Register	Modbus Address	No.of Byte	Data Type	Description	Default Setting	Read Write	Comment
14177	14176	10	string	Unit Name 23	Ncfm	R	UTF8 string (max 10 character)
14185	14184	10	string	Unit Name 24	m ³	R	UTF8 string (max 10 character)
14193	14192	10	string	Unit Name 25	ltr	R	UTF8 string (max 10 character)
14201	14200	10	string	Unit Name 26	cf	R	UTF8 string (max 10 character)
14209	14208	10	string	Unit Name 27	Nm ³	R	UTF8 string (max 10 character)
14217	14216	10	string	Unit Name 28	Nltr	R	UTF8 string (max 10 character)
14225	14224	10	string	Unit Name 29	Ncf	R	UTF8 string (max 10 character)
14233	14232	10	string	Unit Name 30	ppm	R	UTF8 string (max 10 character)
14241	14240	10	string	Unit Name 31	atm°C	R	UTF8 string (max 10 character)
14249	14248	10	string	Unit Name 32	atm°F	R	UTF8 string (max 10 character)
14257	14256	10	string	Unit Name 33	pa	R	UTF8 string (max 10 character)
14265	14264	10	string	Unit Name 34	hpa	R	UTF8 string (max 10 character)
14273	14272	10	string	Unit Name 35	kpa	R	UTF8 string (max 10 character)
14281	14280	10	string	Unit Name 36	Mpa	R	UTF8 string (max 10 character)
14289	14288	10	string	Unit Name 37	mbar	R	UTF8 string (max 10 character)
14297	14296	10	string	Unit Name 38	bar	R	UTF8 string (max 10 character)
14305	14304	10	string	Unit Name 39	psi	R	UTF8 string (max 10 character)
14313	14312	10	string	Unit Name 40	mV	R	UTF8 string (max 10 character)
14321	14320	10	string	Unit Name 41	V	R	UTF8 string (max 10 character)
14329	14328	10	string	Unit Name 42	μV	R	UTF8 string (max 10 character)
14337	14336	10	string	Unit Name 43	kV	R	UTF8 string (max 10 character)
14345	14344	10	string	Unit Name 44	mA	R	UTF8 string (max 10 character)

Modbus Register	Modbus Address	No.of Byte	Data Type	Description	Default Setting	Read Write	Comment
14353	14352	10	string	Unit Name 45	A	R	UTF8 string (max 10 character)
14361	14360	10	string	Unit Name 46	kg/s	R	UTF8 string (max 10 character)
14369	14368	10	string	Unit Name 47	kg	R	UTF8 string (max 10 character)
14377	14376	10	string	Unit Name 48	∅ m ³ /h	R	UTF8 string (max 10 character)
14385	14384	10	string	Unit Name 49	∅ l/h	R	UTF8 string (max 10 character)
14393	14392	10	string	Unit Name 50	∅ kg/h	R	UTF8 string (max 10 character)
14401	14400	10	string	Unit Name 51	∅ cf/h	R	UTF8 string (max 10 character)
14409	14408	10	string	Unit Name 52	kg/h	R	UTF8 string (max 10 character)
14417	14416	10	string	Unit Name 53	kg/min	R	UTF8 string (max 10 character)
14425	14424	10	string	Unit Name 54	Ω	R	UTF8 string (max 10 character)
14433	14432	10	string	Unit Name 55	Hz	R	UTF8 string (max 10 character)
14441	14440	10	string	Unit Name 56	%	R	UTF8 string (max 10 character)
14449	14448	10	string	Unit Name 57	kW	R	UTF8 string (max 10 character)
14457	14456	10	string	Unit Name 58	kWh	R	UTF8 string (max 10 character)
14465	14464	10	string	Unit Name 59	PCS	R	UTF8 string (max 10 character)
14473	14472	10	string	Unit Name 60	kVA	R	UTF8 string (max 10 character)
14481	14480	10	string	Unit Name 61	kVAr	R	UTF8 string (max 10 character)
14489	14488	10	string	Unit Name 62	-	R	UTF8 string (max 10 character)
14497	14496	10	string	Unit Name 63	€	R	UTF8 string (max 10 character)
15505	15504	10	String	Unit Name 63	cts/m ³	R	UTF8 string (max 10 character)

9 Appendix

9.1 APPENDIX A - Exception codes

The DS500 Modbus uses the following exception codes when responding to the master

Exception Code	Exception name
0x01	Illegal function
0x02	Illegal data address
0x03	Illegal data value
0x04	Slave device failure
0x05	Acknowledge
0x06	Slave device busy