

# Instruction manual

## Vortex Ultrasonic

### Flow sensor VU 570



#### SALES OFFICE SOUTH

Zindelsteiner Straße 15  
D-78052 VS-Tannheim  
DEUTSCHLAND  
Tel.: +49 (0) 7705 978 99-0  
Fax: +49 (0) 7705 978 99-20

#### SALES OFFICE NORTH

Gewerbehof 14  
D-24955 Harrislee  
Deutschland  
Tel.: +49 (0) 461 807 150 0  
Fax: +49 (0) 461 807 150 15

[info@cs-instruments.com](mailto:info@cs-instruments.com)  
<http://www.cs-instruments.com/en>

## I. Forword



Read these operating instructions carefully and completely before installation, start-up and maintenance work. Follow the instructions to ensure safe operation and proper functioning.

The operating instructions must always be available at the place of use. It is not permitted to make only individual pages available.

## II. Table of Content

<b>1</b>	<b>Scope of delivery</b>	<b>5</b>
<b>2</b>	<b>Name plate</b>	<b>5</b>
<b>3</b>	<b>Intended Use</b>	<b>5</b>
<b>4</b>	<b>Safety instructions</b>	<b>6</b>
4.1	In this manual warning and information symbols used	6
4.2	Warnings	6
4.3	General safety instructions Sicherheitshinweise	7
4.4	Environmental protection	8
<b>5</b>	<b>Product information</b>	<b>9</b>
5.1	Product features	9
5.2	Measuring ranges (under operating conditions)	9
<b>6</b>	<b>Technical data</b>	<b>10</b>
6.1	Technical data and environmental conditions	10
<b>7</b>	<b>Installation</b>	<b>11</b>
7.1	General notes for the Installation	11
7.2	Storage	11
7.3	Transport	11
7.4	Pipe/tube requirements	11
7.5	Inlet / outlet runs	12
<b>8</b>	<b>Commissioning</b>	<b>13</b>
8.1	Installation position	13
8.2	Alignment Display (Housing	13
<b>9</b>	<b>Dimension</b>	<b>14</b>
9.1	Flange Version	14
9.2	R-Thread Version	15
<b>10</b>	<b>Electrical wiring</b>	<b>16</b>
10.1	Cable glands – clamping range	16
10.2	Connector pin assignment	16
10.3	Wiring	18
10.3.1	General	18
10.3.2	S Power Supply	18
10.3.3	Modbus RTU :	18
10.3.4	Modbus TCP (Ethernet) Optional PoE*	19
10.3.5	Pulse output	19

<b>11</b>	<b>Operation</b>	<b>20</b>
11.1	<b>Main menu (Home)</b>	<b>21</b>
11.1.1	Initialization	21
11.2	<b>Value screens (after switching on)</b>	<b>21</b>
11.3	<b>Settings</b>	<b>22</b>
11.3.1	Sensor Setup	23
11.3.1.1	Input / change tube diameter	23
11.3.1.2	Input / change consumption counter	24
11.3.1.3	Definition of the units for flow, velocity, temperature and pressure	24
11.3.1.4	Definition of the reference conditions	25
11.3.2	Modbus RTU	27
11.3.2.1	Setup	27
11.3.3	Modbus TCP (Optional)	28
11.3.3.1	Setup	28
11.3.3.1.1	Network Setup DHCP .....	28
11.3.3.1.2	Network Settings static IP.....	29
11.3.3.1.3	Modbus TCP Settings.....	30
11.3.3.2	Modbus Settings (2001...2005)	31
11.3.3.3	Values Register (1001 ...1500)	31
11.3.4	Pulse /Alarm	33
11.3.4.1	Pulse output	33
11.3.5	User Setup	34
11.3.5.1	Password	34
11.3.5.2	Language	34
11.3.5.3	Display / Touch	35
11.3.6	Advanced	35
11.3.7	4 -20mA	36
11.3.8	VU 570 Info	38
11.4	<b>MBus</b>	<b>39</b>
11.4.1	Change communication settings	39
11.4.2	Coding VIF (Value Information Field)	39
11.4.3	Default Settings communication	40
11.4.4	Default values transmitted	40
<b>12</b>	<b>Status / Error messages</b>	<b>41</b>
12.1	<b>Status messages</b>	<b>41</b>
12.2	<b>Error messages</b>	<b>42</b>
<b>13</b>	<b>Maintenance</b>	<b>43</b>
<b>14</b>	<b>Re-Calibration</b>	<b>43</b>
<b>15</b>	<b>Spare parts and repair</b>	<b>43</b>
<b>16</b>	<b>Calibration</b>	<b>43</b>
<b>17</b>	<b>Warranty</b>	<b>43</b>

## 1 Scope of delivery

- Flow-Sensor VU 570
- Calibration certificate
- This instruction manual

## 2 Name plate

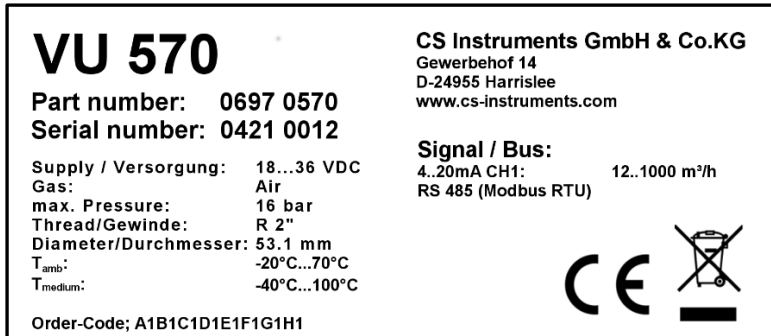

## 3 Intended Use

The VU 570 flow sensor is used for continuous flow measurement, based on the measurement of the vortex shedding frequency, derived from the phenomenon of Karman's vortex street.

The VU 570 flow sensor is designed and constructed exclusively for the intended use described here and may only be used accordingly.

A check as to whether the device is suitable for the selected application must be carried out by the user. It must be ensured that the medium is compatible with the wetted parts. The technical data listed in the data sheet are binding.

Improper handling or operation outside the technical specifications is not permitted. Claims of any kind due to improper use are excluded.

## 4 Safety instructions

### 4.1 In this manual warning and information symbols used

 This symbol is found at all work safety instructions in this operating manual where there is danger to life and limb of persons. Observance of these instructions and cautious behavior are particularly important in these cases. All work safety instructions must also be passed on to other users. In addition to the information in these operating instructions, the general safety and accident prevention regulations must also be observed.

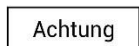



 **Achtung** This symbol is located at the points in the operating instructions that require special attention in order to comply with the guidelines, regulations, instructions and the correct sequence of operations, as well as to prevent damage and destruction.

 This symbol indicates important information or measures for environmental protection.

 This symbol indicates particularly important information for operators.

### 4.2 Warnings

Warnings are subdivided according to the hazard levels **DANGER**, **WARNING** and **CAUTION**. Meaning of the warnings:

- |   |   |
|---|---|
|  | <p><b>Danger</b><br/> <b>Immediate danger!</b><br/> <input type="checkbox"/> Failure to observe this warning may result in serious injury or death.</p>                 |
|  | <p><b>WARNING</b><br/> <b>Possibly dangerous situation!</b><br/> <input type="checkbox"/> Failure to observe this warning may result in serious injury or death.</p>    |
|  | <p><b>Caution</b><br/> <b>Possibly dangerous situation!</b><br/> <input type="checkbox"/> Failure to observe this warning may result in moderate to minor injuries.</p> |
|  | <p><b>Note</b><br/> <b>Possibly dangerous situation!</b><br/> <input type="checkbox"/> Failure to observe this warning may result in property damage.</p>               |

### 4.3 General safety instructions Sicherheitshinweise

#### Important notes for installation and maintenance personnel

Installation of the flow sensor is only permitted by trained skilled staff with knowledge and experience in compressed air and electrical engineering.

Electrical connection, commissioning and maintenance may only be carried out by qualified electricians in accordance with the electrotechnical regulations (DIN EN 50110-1, DIN EN 60204-1 etc.). Prerequisite: Professional training and knowledge of the technical standards, EU directives and EU regulations.

Observe applicable national accident prevention regulations and ordinances. Observe general occupational health and safety measures,

E.g. wear suitable and prescribed personal protective equipment (PPE). Repairs and adjustments may only be carried out by the manufacturer.

#### Duties of the installer and plant operator

The flow sensor must be checked and maintained regularly by an instructed and qualified person.

Cleaning and maintenance intervals are to be determined by the plant operator according to DIN-ISO certification - frequency depending on ambient conditions and expected impairments.

Calibration: As part of DIN ISO certification, have the flow sensor calibrated at regular intervals, after 2 years at the latest.

Remove the flow sensor for calibration and send it to CS Instruments GmbH & Co.KG.



#### Note

▶ Work on power-operated equipment may only be carried out by trained, instructed or by authorized personnel.



#### Note

▶ Without consultation and approval of CS Instruments GmbH & Co. KG the warranty claim is void in case of modification works which are not listed in this operating manual. This symbol is used at points in the operating instructions where special attention must be paid to ensure that the guidelines, regulations, instructions and the correct sequence of operations are observed and damage and destruction are prevented.

**Risk of injury and accidents during operation outside the permissible ambient/operating conditions or operating temperatures due to excess pressure or faulty installation. Depending on the application, the pipeline pressure can be up to 40 bar / 580 psig depending on the application.**

Ensure that the flow sensor is only operated within the permissible limit values (→ type plate, specified max. PS pressure) and that the measuring range end values are taken into account.

**Risk of injury due to unauthorized device modifications, incorrect installation or damaged components.** The operating permit becomes invalid in these cases. **Operation is only permitted with original components.**

Only operate the flow sensor when it is completely assembled. Do not operate a damaged sensor and prevent further use until it has been repaired. The sensor must be checked and maintained regularly by instructed and qualified persons. Device modifications are not permitted and release the manufacturer from any warranty and liability.

**Explosion risk in Ex-protected areas due to ignition of explosive substances when sparks are generated.** The flow sensor does not have Ex approval! Do not use the flow sensor in Ex-protected areas.

#### 4.4 Environmental protection

The flow sensor and also the packaging contain recyclable materials which must not be disposed of in the residual waste. Dispose of the packaging materials and the flow sensor in an environmentally friendly manner at the end of its service life in accordance with the regulations applicable in your country.

The used operating and auxiliary materials as well as replacement parts produced during operation of the flow sensor must be disposed of in accordance with the environmental protection regulations.

DE: Disposal code according to Waste Catalogue Ordinance (AVV) **16 02 14**, electrical and electronic devices and their components.



## 5 Product information

The VU 570 is a flow sensor for air, technical gases and mixed gases (non-aggressive and non-condensing).

### 5.1 Product features

- Measurement of standard volume flow, operating volume flow and mass flow
- Integrated pressure and temperature compensation
- Display with indication of flow, consumption, speed, pressure and temperature
- Units freely selectable m<sup>3</sup>/h, m<sup>3</sup>/min, l/min, l/s, kg/h, kg/min, kg/s, cfm
- Modbus RTU (RS485) interface
- analog output 4..20mA free assignable
- Pulse output galv. insulated.

### 5.2 Measuring ranges (under operating conditions)

Inch	mm	DN	from m/s to		from m <sup>3</sup> /h to		from cfm to	
1/2"	16,1	15	0,5	25	0,4	22,0	0.2	12,9
3/4"	21,7	20			0,7	39,9	0.4	23,5
1"	27,3	25			0,6	63,2	0,4	37,2
1 1/4"	36	32	0,3		1,1	109,9	0,6	64,7
1 1/2"	41,9	40			1,5	148,9	0,9	87,6
2"	53,1	50			2,4	239,2	1,4	140,8
2 1/2"	68,9	65			4,0	402,7	2,4	237,0
3"	80,9	80			5,6	555,2	3,3	326,7

#### Note



► Vortex flow sensors are intended for measuring largely uniform flow velocities. Flow conditions such as pulsating flow or pendulum flow can influence the measurement depending on frequency (> 5 Hz) and amplitude (> 0.3 m/s).

## 6 Technical data

### 6.1 Technical data and environmental conditions

Measurement values	Flow rate, total consumption, pressure, temperature, velocity
Sensor technology	Vortex ultrasonic - vortex frequency measurement
Measuring range	See chapter 5.2 (measuring ranges)
Accuracy	
Volume flow m <sup>3</sup> /h	±1,5 % f.m.**
Mass flow (kg/h) or Standard volume flow (Nm <sup>3</sup> /h)	±2 % f.m.**
Media temperature	-40 ... 100 °C
Ambient temperature	-20 ... 60 °C
Storage temperature	-40 ... 80 °C
Process pressure	Up to 40 bar
Available measuring ranges for integrated pressure sensor (overload)	0 ... 1,5 bar(g) (10 bar) 0 ... 16 bar(g) (60 bar) 0 ... 40 bar(g) (100 bar)
Accuracy pressure	0,5 % v. e. .** (at 20 °C)
Power supply	18 to 36 VDC via SELV supply, 5 W. <b>Option:</b> Power over Ethernet according to IEEE 802.3af, class 2 (3.84 ... 6.49 W).
Signal output	Modbus RTU (RS-485) 1x 4...20 mA (flow, pressure, temperature or velocity) 1x pulse  <b>Option:</b> Ethernet, MBus
Measured values via Modbus	Flow rate (m <sup>3</sup> /min, m <sup>3</sup> /h, cfm, ...) Counter total (m <sup>3</sup> , cf, ...) Temperature (°C, °F) Pressure (bar, MPa, mbar, psi, ...) Air velocity (m/s, fpm)
Protection class	IP 67
Process connection	Flange DIN EN1092-1 Flange ANSI 150lbs/ 300lbs R ½" – R2" (BSP British Standard Piping) ½" - 2" NPT thread

\*\* f.m. = of measured value | f.e. = of final value

## 7 Installation

### 7.1 General notes for the Installation



#### Information!

Check the packaging carefully for damage. In case of damage, please contact the carrier or CS Instruments GmbH & Co.KG.



#### Information!

Check the completeness of the delivery.

### 7.2 Storage

- Store the sensor in a dry and dust-free place
- Store the sensor in the original packaging
- The permissible storage temperatures are -40°C ... 80°C

### 7.3 Transport



#### Attention!

- There is a risk of injury from unsecured devices.  
During transport, prevent the device from slipping or turning unintentionally.
- Do not use transport chains, as these will damage the housing.
- The unit must not be lifted by the housing head for transport.
- For transport, use carrying straps which you place around both process connections.

### 7.4 Pipe/tube requirements

- Correctly sized gaskets
- Correct aligned flanges and gaskets
- Diameter mismatch at the pipe junctions should be avoided but must be less than 1mm. For further information see ISO 14511
- Ensure clean pipes after installation

### 7.5 Inlet / outlet runs

In order to maintain the accuracy stipulated in the data sheets, the sensor must be inserted in the center of a straight pipe section with an undisturbed flow progression.

An undisturbed flow progression is achieved if the sections in front of the sensor (inlet) and behind the sensor (outlet) are sufficiently long, straight and without any obstructions such as edges, seams, curves etc.

Therefore, it is necessary to ensure the recommended inlet and outlet runs.

Flow obstruction before the measurement section	Min length Inlet run (L1))	Min length Outlet run (L2))
Slight curve (elbow < 90°)	12 x D	5 x D
Reduction (Pipe narrows to the measurement section)	15 x D	5 x D
Expansion (Pipe expands to the measurement section)	15 x D	5 x D
90° elbow or T-piece	15 x D	5 x D
2x elbow á 90° in einer Ebene	20 x D	5 x D
2x elbow á 90° 3-dimensional	35 x D	5 x D
Control valve	45 x D	5 x D

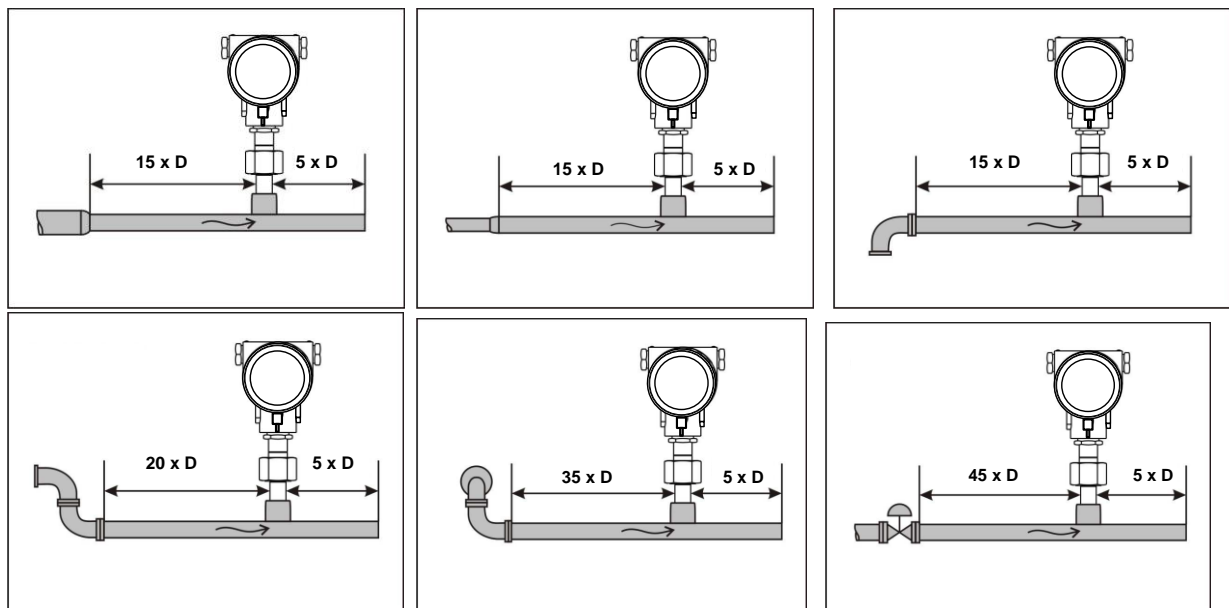

The values represent the min. lengths. In case the min. inlet / outlet runs could not be ensured, it must be expected to get increased or significant deviations of the measurement values.

## 8 Commissioning

- Depressurize the system
- Ensure correct direction of flow during installation
- Maintain an undisturbed flow course while observing the required calming distances in the measuring range, see section 7.5

### 8.1 Installation position

In the case of condensation, only installation with the measuring head aligned vertically is permitted. Otherwise, risk of standing water on ultrasonic sensor. (Functional failure).

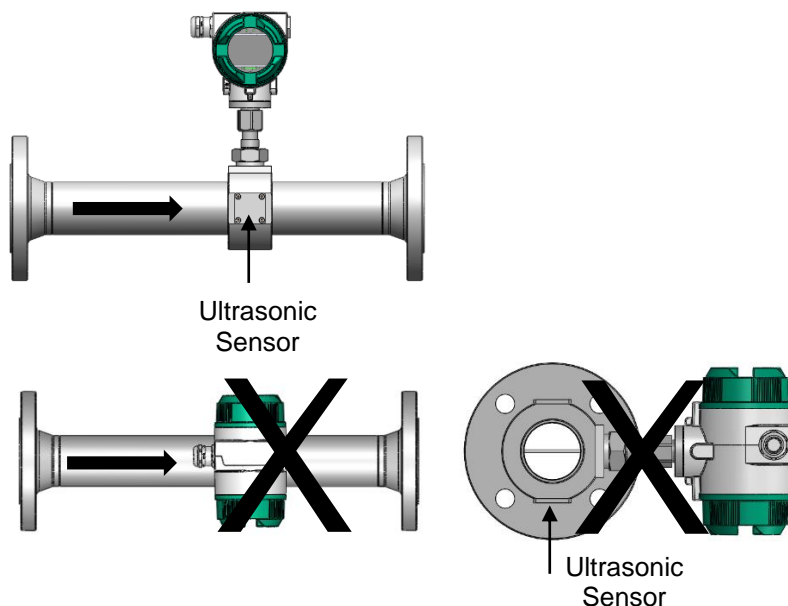

### 8.2 Alignment Display (Housing

The sensor housing VU 570 can be turned in both directions, max. 345 °. For this purpose, the housing-connecting nut must be opened. The housing can be rotated to the desired position, a bigger rotation angle is prevented by internal stop pins.

After that, the housing-connecting nut is firmly retightened

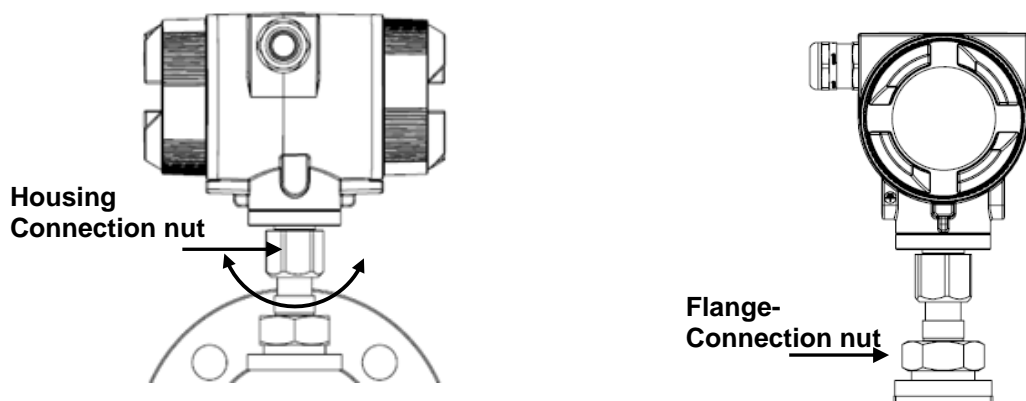

#### Caution!

- The housing connection nut must not be unscrewed/opened completely, it must only be loosened/opened slightly.
- Flange connection nut must not be opened, danger due to sensor head falling off.

## 9 Dimension

### 9.1 Flange Version

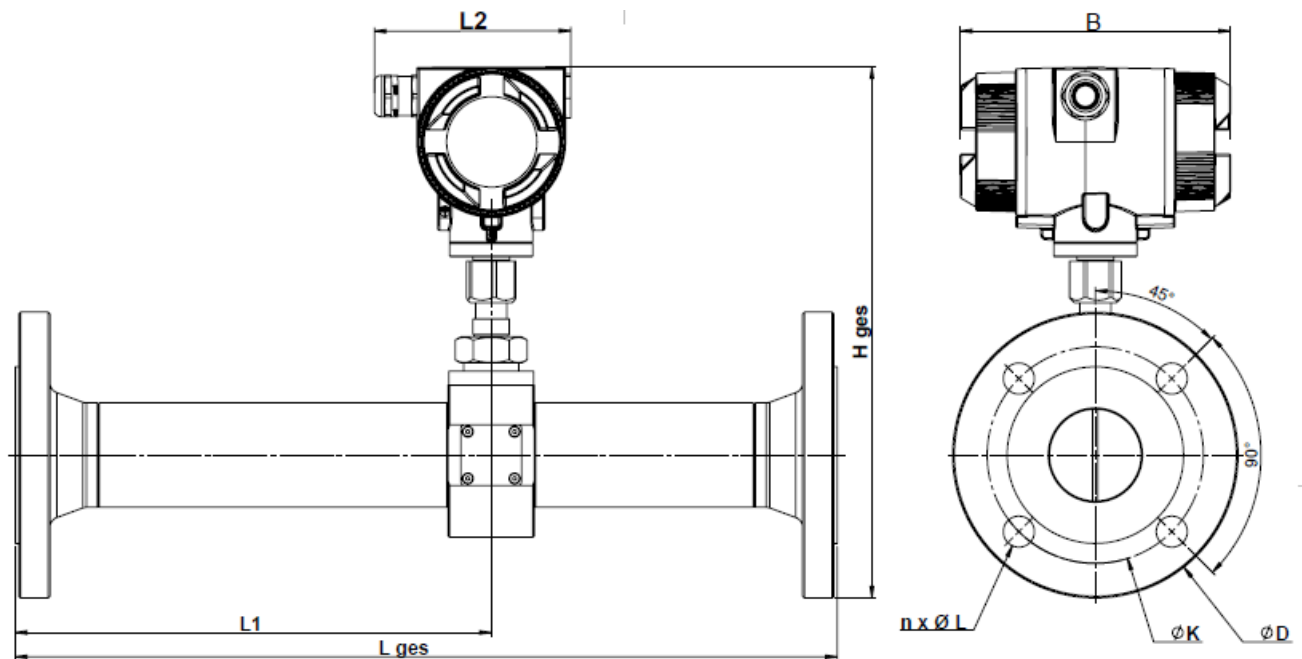

Piper	OD Pipe mm	ID Rohr mm	L ges mm	L1 mm	L2 mm	H ges mm	B mm	Ø D	Ø K	n x Ø L
DN 15	21,3	16,1	300	210	113,4	258,5	156	95	65	4x14
DN 20	26,9	21,7	475	275	113,4	263,5	156	105	75	4x14
DN 25	33,7	27,3	475	275	113,4	276	156	115	85	4x14
DN 32	42,4	36,0	475	275	113,4	288,5	156	140	100	4x18
DN 40	48,3	41,9	475	275	113,4	293	156	150	110	4x18
DN 50	60,3	53,1	475	275	113,4	306,5	156	165	125	4x18
DN 65	76,1	68,9	475	275	113,4	325	156	185	145	8x18
DN 80	88,9	80,9	475	275	113,4	339	156	200	160	8x18

9.2 R-Thread Version

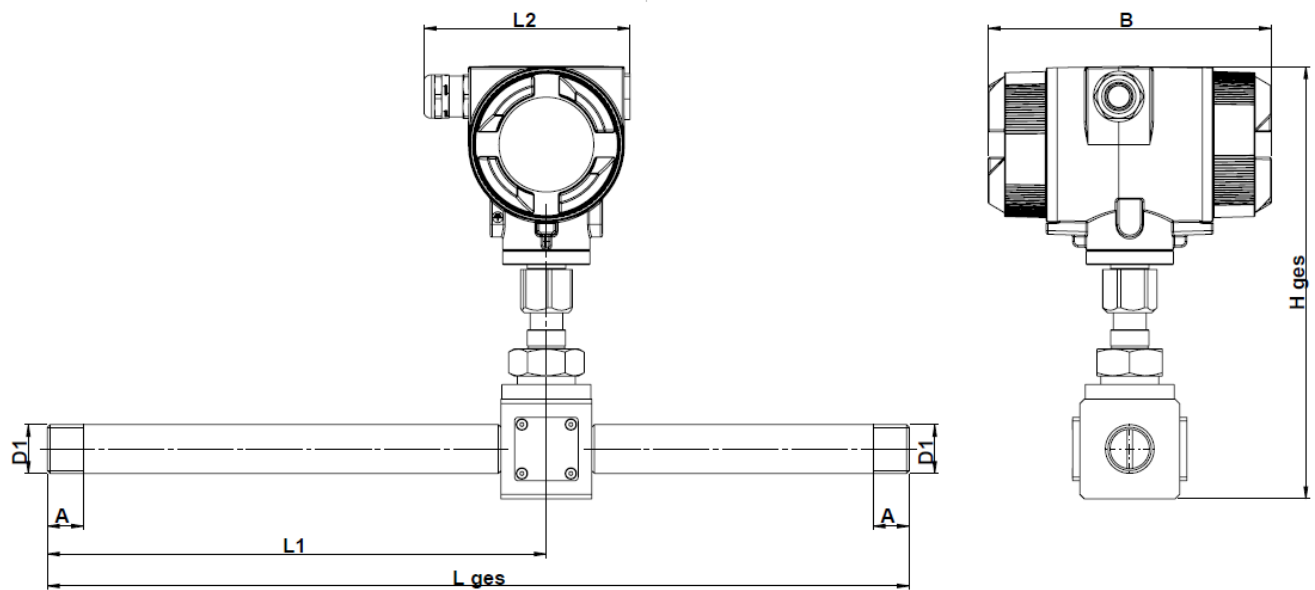

Thread	Piper	OD Pipe mm	ID Rohr mm	L ges mm	L1 mm	L2 mm	H ges mm	B mm	A mm
R 1/2"	DN 15	21,3	16,1	300	210	113,4	238	156	20
R 3/4"	DN 20	26,9	21,7	475	275	113,4	238	156	20
R 1"	DN 25	33,7	27,3	475	275	113,4	253	156	25
R 1 1/4"	DN 32	42,4	36,0	475	275	113,4	253	156	25
R 1 1/2"	DN 40	48,3	41,9	475	275	113,4	260	156	25
R 2"	DN 50	60,3	53,1	475	275	113,4	271	156	30

## 10 Electrical wiring

### 10.1 Cable glands – clamping range

For ensuring the tightness and strain relief, connector cables with the following diameters must be used.

VU 570 Standard clamping range : Ø 5- 9mm

### 10.2 Connector pin assignment

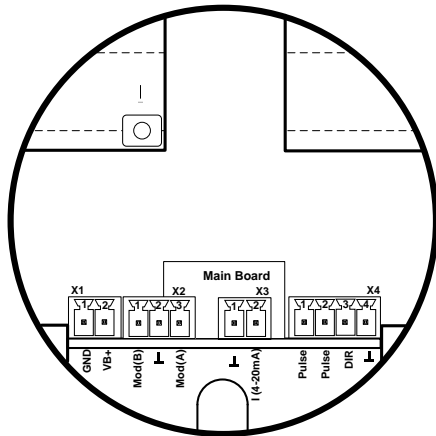

Standard version with 1x analogue output (not galvanically isolated)

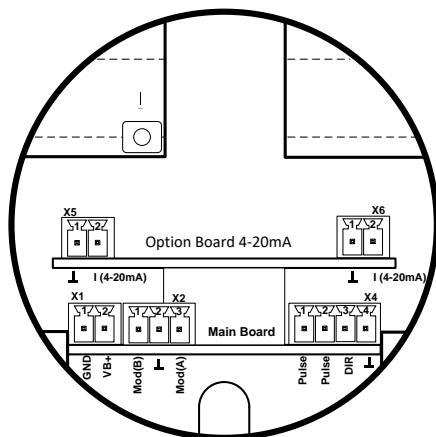

Version with option board 2x analogue outputs galvanically isolated

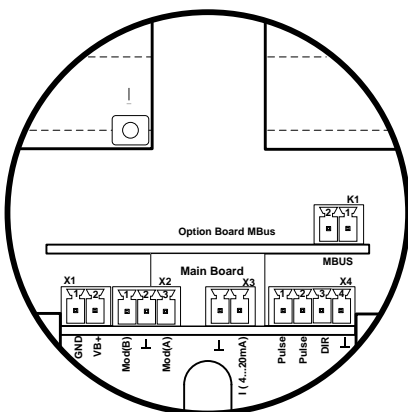

Version with option board MBUS



Connector	Pin	Signal Description
<b>X1</b> Power supply	1	VB - (GND)
	2	VB+
<b>X2</b> Modbus	1	Modbus (B)
	2	Modbus shield
	3	Modbus (A)
<b>X3</b> current output	1	I- Active
	2	I+ Active
<b>X4</b> Direction / Pulse	1	Pulse / Alarm *
	2	Pulse / Alarm *
	3	Direction input
	4	GND
<b>X5</b> Current output 1	1	I- Active**
	2	I+ Active **
<b>X6</b> Current output 2	1	I- Active **
	2	I+ Active **
<b>K1</b> Mbus	1	Mbus
	2	Mbus

\* Outputs are galvanically isolated.

\*\* The Current outputs, X5 and X6, are optional. (Active and passive version available).

### 10.3 Wiring

#### 10.3.1 General

- Wiring to be done in strain less state only.
- Length of cable skinning to be minimized
- Not used cable entries must be closed with end caps
- Use of cables with cross section of  $\geq 0.25\text{mm}^2$

#### 10.3.2 Power Supply

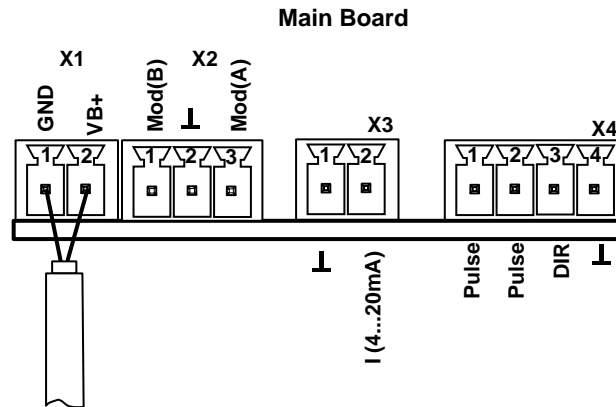

#### 10.3.3 Modbus RTU :

If the sensor placed at the end of the Modbus system a termination is required. Therefore, the enclosed 120R resistor is to be connected at Pin 1 and Pin 3 of connector „X2“

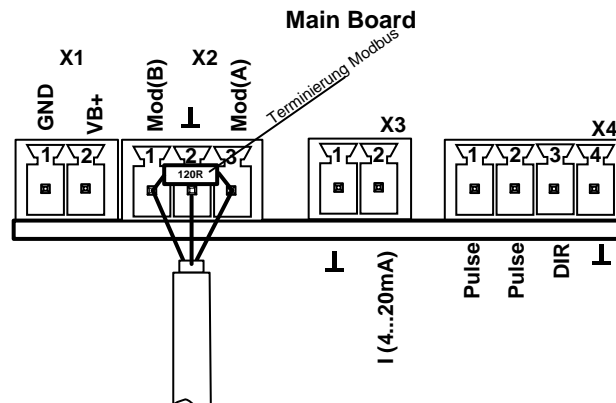

### 10.3.4 Modbus TCP (Ethernet) Optional PoE\*

M12 x-coded

Data LINES: 1,2 und 3,4

PoE LINES: 5,6 und 7,8

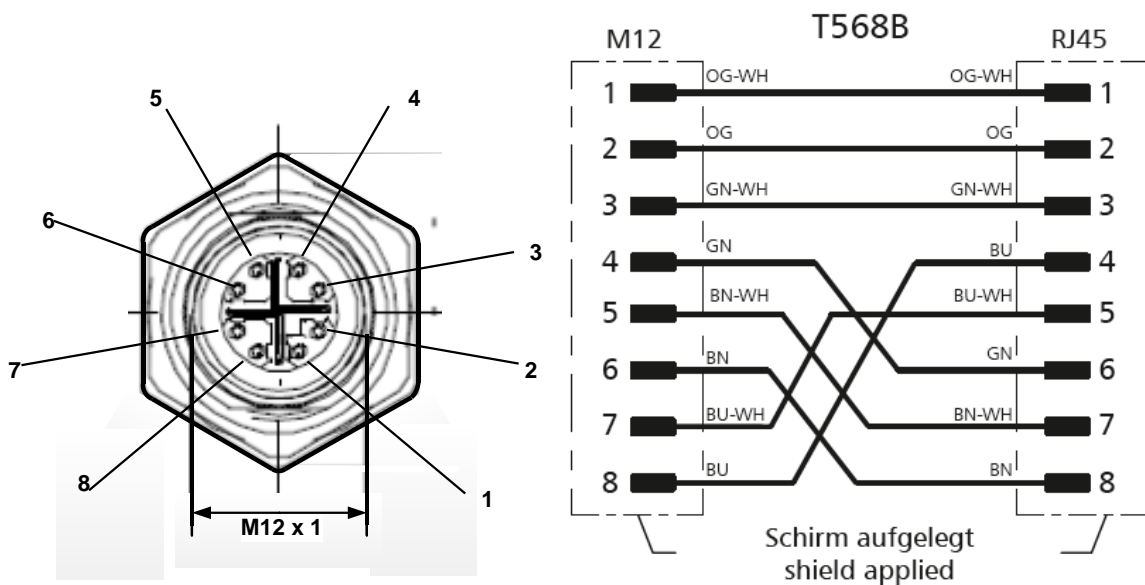

Connection cable: Cat 6.

\*PoE: Power over Ethernet

### 10.3.5 Pulse output

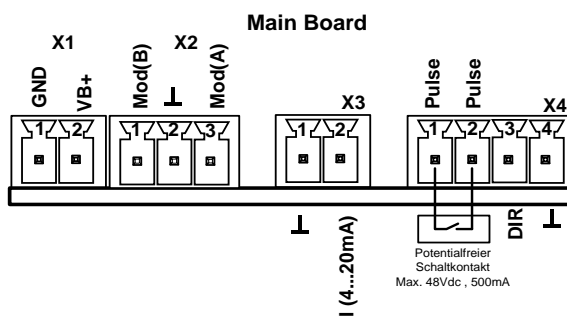

## 11 Operation

The operation of the VU 570 is carried out by 2 optical keys through the glass cover. Thus, the VU 570 can be operated from the outside without opening the cap.

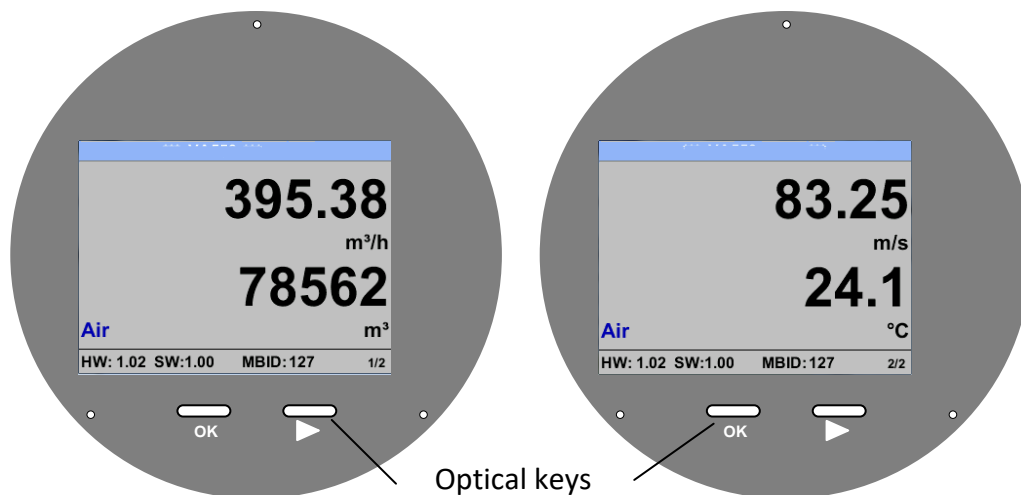

Selection of the individual menu items is done by pressing the ">" and confirm by pressing "**OK**".

Inputs or changes can be made with all white deposit fields, selected filed will be highlighted with yellow background.

Words in **green font** refer mainly to the pictures in the section of the chapter, but also on important menu paths or menu items that are related to are in **green font**.

The menu navigation is generally in a **green font**!

The table of contents and chapter references in **blue font** contain links to the respective chapter title.

11.1 Main menu (Home)

11.1.1 Initialization



After switching on the VU 570 the initialized screen is displayed followed by the main menu.

11.2 Value screens (after switching on)

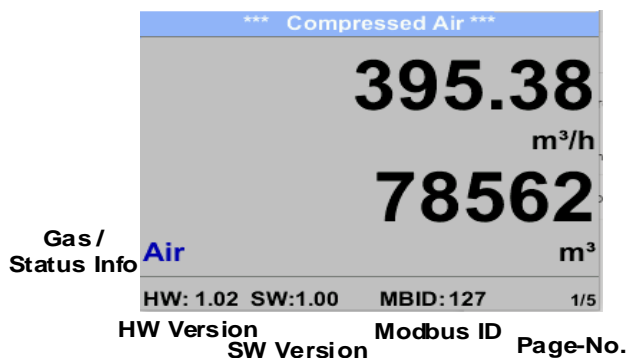

Switching to pages 2-5 or back by pressing key „>“

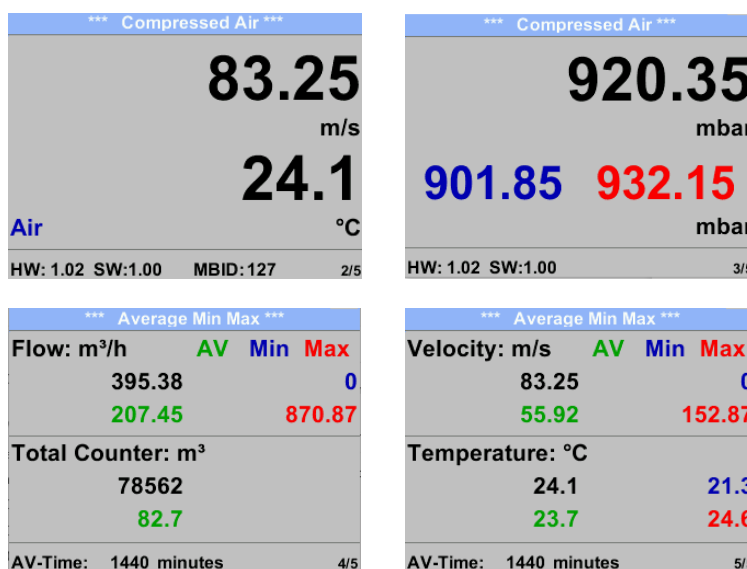

AV-Time (Period for average value calculation) could be changed under *Sensor Setup.-Advanced- AV-Time.*

### 11.3 Settings

The settings menu could accessed by pressing the key „OK“.  
 But the access to the *settings menu* is password protected.



Factory settings for password at the time of delivery: 0000 (4 times zero).  
 If required the password could be changed at *Setup–User setup-Password*.

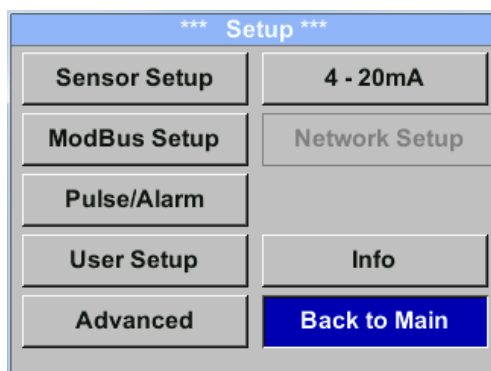

Selection of a menu item or to change a value is done with the key „>“, a final move to the chosen menu item or takeover of the value change needs the confirmation by pressing the key „OK“

### 11.3.1 Sensor Setup

Setup → Sensor Setup

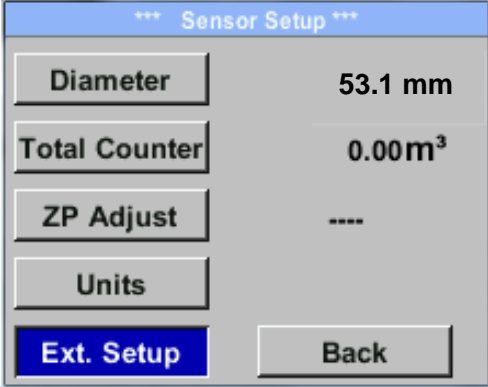

The screenshot shows a menu titled "Sensor Setup" with the following options and values:

Option	Value
Diameter	53.1 mm
Total Counter	0.00m <sup>3</sup>
ZP Adjust	----
Units	
Ext. Setup	
Back	

For changes, first select the menu item with key **>** and then confirm it with **OK**.

#### 11.3.1.1 Input / change tube diameter

With VU 570 not changeable(locked) because adjusted to the integrated measuring section.

11.3.1.2 Input / change consumption counter

Setup → Sensor Setup → Total Counter → Unit button

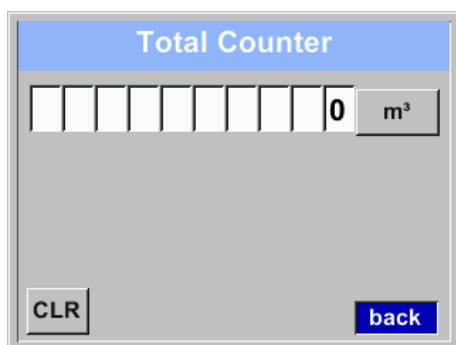
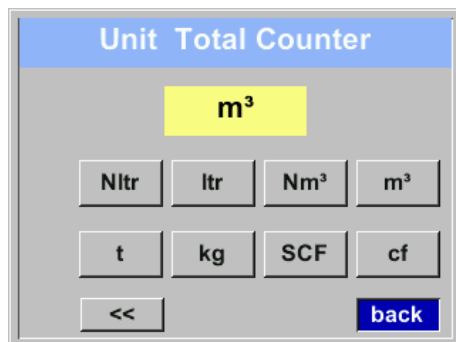

In order to change, e.g. the unit, first select by pressing key „>“ the button **“Unit”** and then key **“OK”**.

Select with the key „>“ the correct unit and then confirm selection by pressing 2x **„OK“**.

Entering / changing the consumption counter via button „>“, select the respective position and activate the position with the **“OK”** button. By pressing „>“ the position value is incremented by 1. Complete with **“OK”** and activate next number position.

Confirm entry by pressing **„OK“**.

**Important!**

**When the counter reach 10000000 m³ the counter will be reset to zero.**

11.3.1.3 Definition of the units for flow, velocity, temperature and pressure

Setup → Sensor Setup → Units

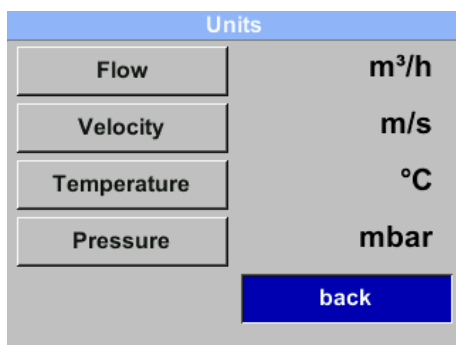

To make changes to the unit for the respective measurement value, first select by pressing „>“ the field of the „measurement value“ and activate „it with **„OK“** .

Selection of the new unit with „>“

In case the quantity of units selectable are not presentable on one page, pleas move to next page by pressing **„<<“**.

Confirm selection by pressing 2x **„OK“**.

Procedure for all 4 measurement-variables is analogous.

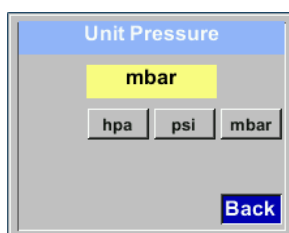
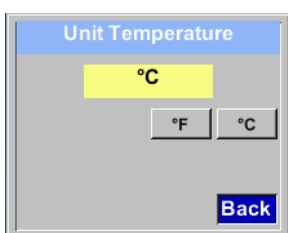
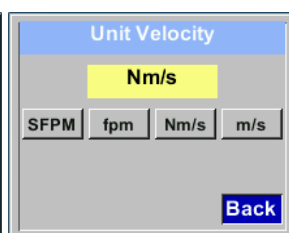
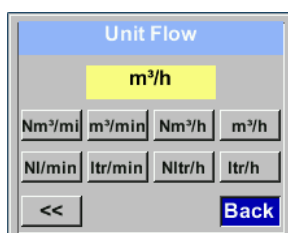



### 11.3.1.4 Definition of the reference conditions

Here can be defined the desired measured media reference conditions for pressure and temperature and times for the filter and averaging.

- Factory pre-setting for reference temperature and reference pressure are 20 °C, 1000 hPa
- All volume flow values (m³/h) and consumption values indicated in the display are related to 20 °C and 1000 hPa (according to ISO 1217 intake condition)
- Alternatively 0 °C and 1013 hPa (=standard cubic meter) can also be entered as a reference.
- **Do not enter the operation pressure or the operation temperature under reference conditions!**

#### Setup → Sensor Setup → Advanced

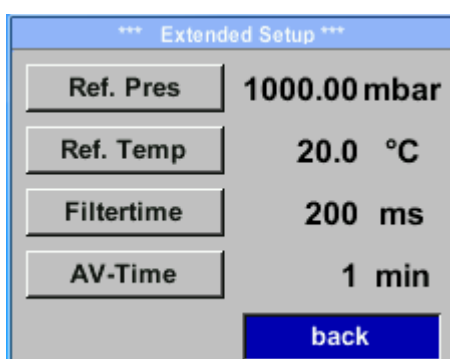

To make changes, first select a menu with button „>“ and confirm selection by pressing „OK“.

#### Setup → Sensor Setup → Advanced → Ref.Pref

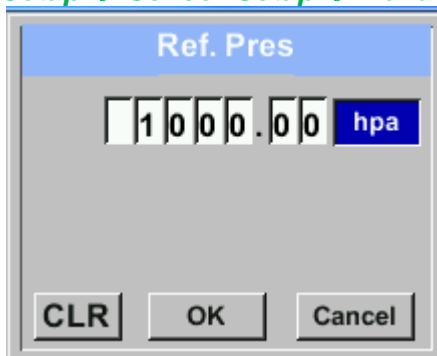

In order to change, e.g. the unit, first select by pressing key „>“ the field **“Units”** and then key **“OK”**.  
Select with the key „>“ the correct unit and then confirm selection by pressing 2x **„OK”**.

Input / change of the value by selecting the respective position with button „>“ and entering by pressing button **„OK”**.

#### Setup → Sensor Setup → Advanced → Ref.Temp

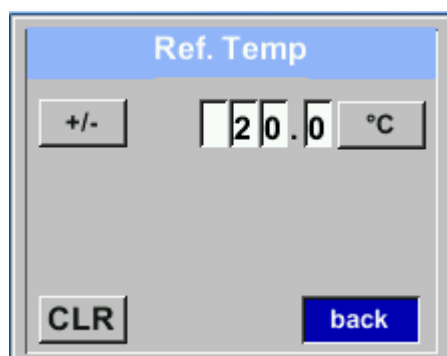

By pressing „>“ the position value is incremented by 1. Complete with **“OK”** and activate next number position.

Procedure for changing the reference temperature is the same.

Setup → Sensor Setu→ Advanced → *Filtertime*

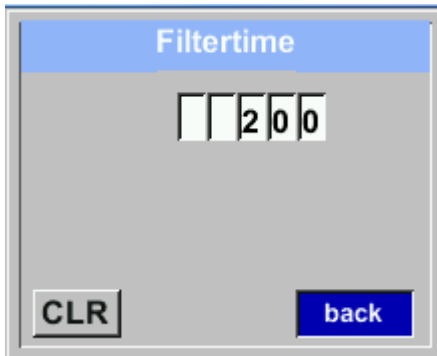

Under item "*Filtertime*" an attenuation can be defined.  
Input values of 0 -10000 in [ms] are possible

Setup → Sensor Setup→ Advanced → *AV-Time*

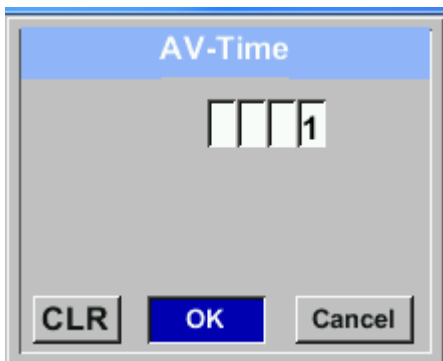

The time period for averaging can be entered here.  
Input values of -1440 1 [minutes] are possible.  
For average values, see display window 3 + 4.

### 11.3.2 Modbus RTU

#### 11.3.2.1 Setup

The Flow sensors VU 570 comes with a Modbus RTU Interface. Before commissioning the sensor the communication parameters

- Modbus ID, Baud rate, Parity und Stop bit

must be set in order to ensure the communication with the Modbus master.

#### Settings → Modbus Setup

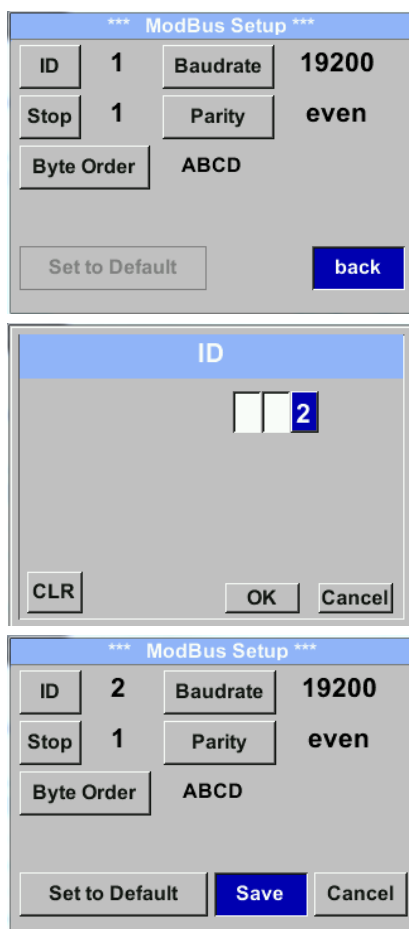

For changes, e.g. the sensor ID, first select by pressing key „>“ the field “ID” and then key “OK”.

Select the desired position by pressing the “>” and select with “OK” button.

Change values by pressing the „>“ values takeover by pressing “OK”.

Inputs for baud rate, stop bit and parity is done analogue.

By means of the button "Byte Order" it is possible to change the data format (Word Order). Possible formats are "ABCD" (Little Endian) and "CDAB" (Middle Endian)

Saving the changes by pressing “Save”, therefore select it with key „>“ and then confirm it with “OK”.

Reset to the default settings by activating “Set to Default”-

#### Default values out of factory:

Modbus ID: 1  
 Baud rate: 19200  
 Stopbit: 1  
 Parity: even  
 Byte Order: ABCD

**Remark:** If the sensor placed at the end of the Modbus system, a termination is required.

Therefore, the enclosed 120R resistor is to be connected at Pin 1 and Pin 3 of connector „X2“

### 11.3.3 Modbus TCP (Optional)

#### 11.3.3.1 Setup

The Flow sensors VU 570 comes optional with a Modbus TCP Interface (HW Interface:M12 x 1 X-coded connector).

Device supports with this option the Modbus TCP protocol for communication with SCADA systems. TCP port is set to 502 by default. Port can be changed at the sensor or using PC Service Software

Modbus device address (Unit Identifier) can be set in the range of 1- 255.

Specification and description of the Modbus protocol is free to download on: [www.modbus.org](http://www.modbus.org).

Supported Modbus commands (functions):

Command	Code	Description
Function Code	3	(Read holding register)
Function code	16	(Write multiple registers)

For more details, please see **VA 5xx Modbus RTU\_TCP Installation V1.09**

#### Settings → Network Setup

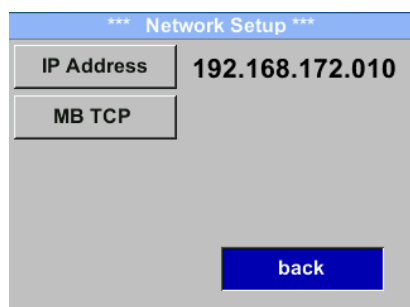

#### 11.3.3.1.1 Network Setup DHCP

#### Settings → Network Setup Settings → IP Address

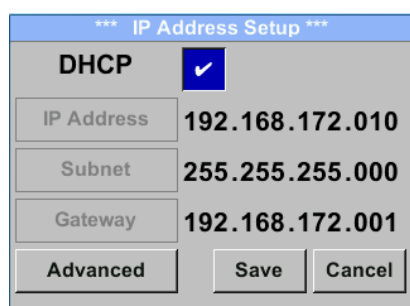

Here you can set up and made a connection, with or without *DHCP*, to a computer.

**Remark:**

With activated *DHCP* the automatic integration of the sensor in an existing network is possible, without a manual configuration.

Storing of settings by pressing “*Save*”

11.3.3.1.2 Network Settings static IP

Settings → Network Setup Settings → IP Address → IP Address

Settings → Network Setup Settings → IP Address → Sub Netz

Settings → Network Setup Settings → IP Address → Gateway

\*\*\* IP Address Setup \*\*\*

DHCP

IP Address 192.168.172.010

Subnet 255.255.255.000

Gateway 192.168.172.001

Advanced back

\*\*\* IP Address Setup \*\*\*

DHCP

IP Address 192.168.172.010

Subnet 255.255.255.000

Gateway 192.168.172.001

Advanced back

IP Setup

1 9 2

CLR back

For manual (static) IP, the "IP Address", "Subnet" and "Gateway" selection keys must be selected and activated with "OK".

The first data field of the selection, in this case the IP address, is then marked (red).

Confirm with "OK" the corresponding input menu is opened.

By means of ">", the next data field is changed.

Select the desired position with the ">" key and activate it with the "OK" key.

Change the values with the ">" key, and accept the values with the "OK" key.

Procedure for "Subnet" and "Gateway" is analogous.

Subnet Setup

2 5 5

CLR back

Gateway Setup

1 9 2

CLR back

\*\*\* IP Address Setup \*\*\*

DHCP

IP Address 192.168.172.011

Subnet 255.255.255.000

Gateway 192.168.172.001

Advanced Save Cancel

Store the settings by pressing „Save“

11.3.3.1.3 Modbus TCP Settings

Settings → Network Setup Settings → MB TCP

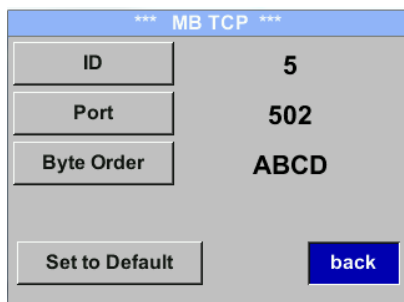

Settings → Network Setup Settings → IP Address → ID

Settings → Network Setup Settings → IP Address → Port

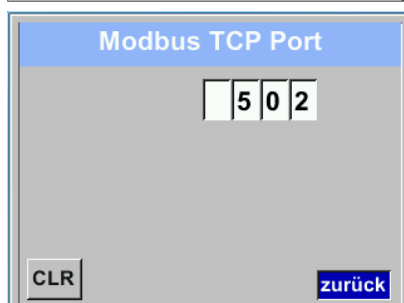
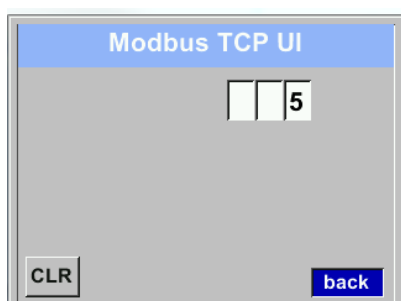

For changes, e.g. the sensor ID, first select by pressing key „>“ the field “ID” and then key “OK”.

Select the desired position by pressing the ">" and select with "OK" button.

Change values by pressing the „>“ values takeover by pressing "OK".

Input for the port is done analogue.

By means of the button "Byte Format" it is possible to change the data format (Word Order). Possible formats are "ABCD" (Little Endian) and "CDAB" (Middle Endian)

Saving the changes by pressing "Save", therefore select it with key „>“ and then confirm it with "OK".

Reset to the default settings by activating "Set to Default"-

**11.3.3.2 Modbus Settings (2001...2005)**

Modbus Register	Register Address	No.of Byte	Data Type	Description	Default Setting	Read Write	Unit /Comment
2001	2000	2	UInt16	Modbus ID	1	R/W	Modbus ID 1...247
2002	2001	2	UInt16	Baudrate	4	R/W	0 = 1200 1 = 2400 2 = 4800 3 = 9600 4 = 19200 5 = 38400
2003	2002	2	UInt16	Parity	1	R/W	0 = none 1 = even 2 = odd
2004	2003	2	UInt16	Number of Stopbits		R/W	0 = 1 Stop Bit 1 = 2 Stop Bit
2005	2004	2	UInt16	Word Order	0xABCD	R/W	0xABCD = Big Endian 0xCDAB = Middle Endian

**11.3.3.3 Values Register (1001 ...1500)**

Modbus Register	Register Address	No.of Byte	Data Type	Description	Default	Read Write	Unit /Comment
1101	1100	4	Float	Flow in m³/h		R	
1109	1108	4	Float	Flow in Nm³/h		R	
1117	1116	4	Float	Flow in m³/min		R	
1125	1124	4	Float	Flow in Nm³/min		R	
1133	1132	4	Float	Flow in ltr/h		R	
1141	1140	4	Float	Flow in Nltr/h		R	
1149	1148	4	Float	Flow in ltr/min		R	
1157	1156	4	Float	Flow in Nltr/min		R	
1165	1164	4	Float	Flow in ltr/s		R	
1173	1172	4	Float	Flow in Nltr/s		R	
1181	1180	4	Float	Flow in cfm		R	
1189	1188	4	Float	Flow in Ncfm		R	
1197	1196	4	Float	Flow in kg/h		R	
1205	1204	4	Float	Flow in kg/min		R	
1213	1212	4	Float	Flow in kg/s		R	
1221	1220	4	Float	Flow in kW		R	

Modbus Register	Register Address	No.of Byte	Data Type	Description	Default	Read Write	Unit /Comment
1269	1268	4	UInt32	Consumption m <sup>3</sup> before comma	x	R	
1275	1274	4	UInt32	Consumption Nm <sup>3</sup> before comma	x	R	
1281	1280	4	UInt32	Consumption ltr before comma	x	R	
1287	1286	4	UInt32	Consumption Nltr before comma	x	R	
1293	1292	4	UInt32	Consumption cf before comma	x	R	
1299	1298	4	UInt32	Consumption Ncf before comma	x	R	
1305	1304	4	UInt32	Consumption kg before comma	x	R	
1311	1310	4	UInt32	Consumption kWh before comma	x	R	
1347	1346	4	Float	Velocity m/s	x	R	
1355	1354	4	Float	Velocity Nm/s	x	R	
1363	1362	4	Float	Velocity Ft/min	x	R	
1371	1370	4	Float	Velocity NFt/min	x	R	
1419	1418	4	Float	GasTemp °C	x	R	
1427	1426	4	Float	GasTemp °F	x	R	
1475	1474	4	Float	System pressure mbar	x	R	Only with option pressure available
1481	1480	4	Float	System pressure bar	x	R	Only with option pressure available
1487	1486	4	Float	System pressure psir	x	R	Only with option pressure available

- For DS400 / DS 500 / Handheld devices - Modbus Sensor Datatype „Data Type R4-32“ match with „Data Type Float“
- For more additional Modbus values please refer to VA5xx\_Modbus\_RTU\_TCP Installation\_1.09\_EN.doc



### 11.3.4 Pulse /Alarm

Setup → Sensor Setup → Pulse/ Alarm

Relay Mode:	Alarm	
Unit	°C	
Value	20.0	
Hyst.	5.0	
Hi-Lim.	OK	Cancel

*** Pulse / Alarm ***		
Relay Mode:	Alarm	
Unit:	°C	
Value	20.0	
Hyst.	5.0	
Hi-Lim.	OK	Cancel

*** Pulse / Alarm ***		
Relay Mode:	Pulse	
Unit:	m³	
Value	0.1	
Polarity	pos.	
Pls per second at max Speed: 0		
	Back	

The galvanically isolated output can be defined as pulse- or alarm output. Selection of field „**Relay Mode**“ with key „>“ and change modus by pressing key „OK“.

For alarm output following units could be chosen: kg/min, cfm, ltr/s, m³/h, m/s, °F, °C and kg/s. „**Value**“ defines the Alarm value, „**Hyst.**“ defines the desired hysteresis and with „**Hi-Lim**“ or „**Lo-Lim**“ the alarm settings when the alarm is activated

Hi-Lim: Value over limit  
Lo-Lim: Value under limit

For the pulse output following units could be chosen: kg, cf, ltr and m³. The pulse value definition to be done in menu „**Value**“ . Lowest value is depending on max. flow of sensor and the max frequency of pulse output of 50Hz.

With „**Polarity**“ the switching state could be defined. Pos. = 0 → 1 neg. 1 → 0

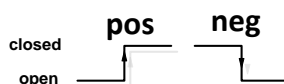

#### 11.3.4.1 Pulse output

The maximum frequency for pulse output is 50 pulses per second (50Hz). The Pulse output is delayed by 1 second.

Pulse value	[m³ /h]	[m³ /min]	[l/min]
0.1 ltr / Pulse	18	0,3	300
1ltr / Pulse	180	3	3000
0.1m³ / Pulse	18000	300	300000
1 m³ / Pulse	180000	3000	3000000

Table 1 Maximum flow for pulse output

Entering pulse values that are not allow a presentation to the full scale value, are not allowed. Entries are discarded and error message displayed.

### 11.3.5 User Setup

#### 11.3.5.1 Password

Settings → User Setup → Password

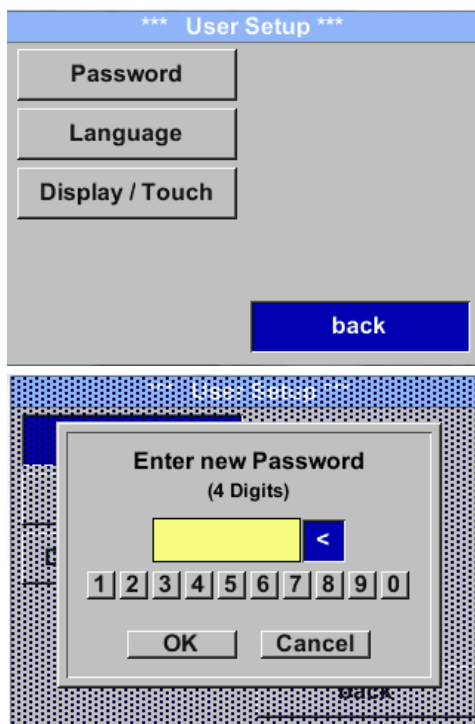

To make changes, first select a menu with button „>“ and confirm selection by pressing „OK“ .

It is possible to define a password. The required password length is 4 digits. Please select with button „>“ a figure and confirm it with „OK“ .Repeat this 4 times.

With „<“ the last figure could be deleted. Password input have to be inserted twice.

Confirmation of input/password by pressing „OK“.

**Factory settings for password at the time of delivery: 0000 (4 times zero).**

#### 11.3.5.2 Language

Settings → UserSetup → Language

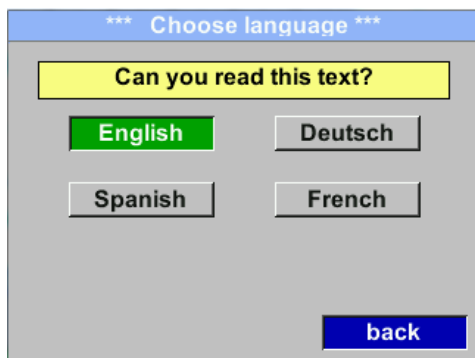

Currently 4 languages have been implemented and could be selected with button „>“.

Change of language by confirming with “OK”. Leaving the menu with button “back”.

### 11.3.5.3 Display / Touch

Settings → UserSetup → Display / Touch

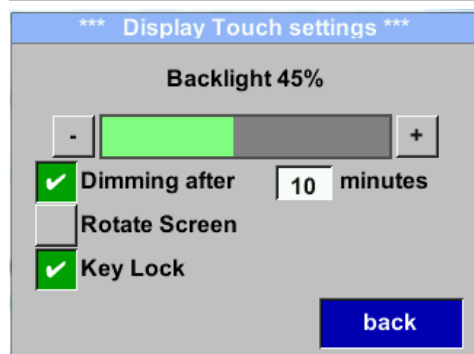
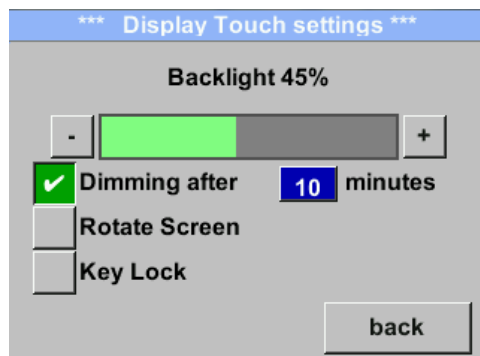

With the button „-“ and with button „+“ it is possible to adjust the backlight / display brightness. The actual / adjusted backlight brightness is shown in the graph „Backlight.“

By activation “Dimming after” and entering a time a display dimming could be set.

With „Rotate Screen“ the display information could be rotated by 180°.

By activation of „Key Lock“ the operation of the sensor locked.

Unlocking the keyboard is only possible by restarting the sensor and calling the operating menu within the first 10s. To do this, use the “OK” button to enter the operating menu during this period.

### 11.3.6 Advanced

Settings → Advanced

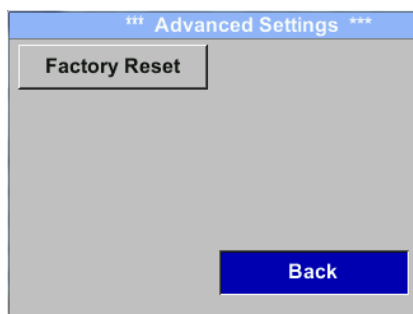

By pressing „Factory Reset“ the sensor is set back to the factory settings.

### 11.3.7 4 -20mA

#### Settings → 4-20mA

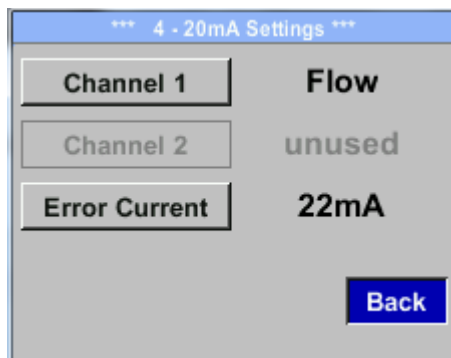

To make changes, first select an item with „>“ and confirm selection by pressing „OK“.

#### Settings → 4-20mA → Channel 1

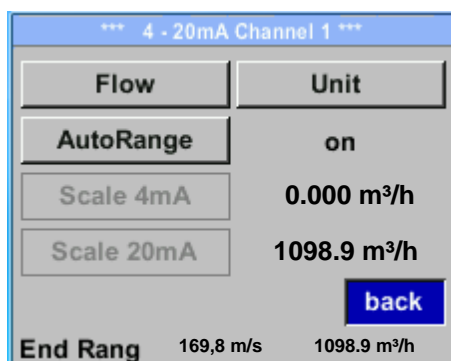

The 4-20 mA Analogue output of the Sensor VU 570 can be individually adjusted.

It is possible to assign following values „Temperature“, „Velocity“ und „Flow“ to the channel CH 1.

To make changes, first select the value item with button „>“.and confirm Moving between the different measurements values or to deactivate the 4-20mA with setting to „unused“ by pressing „OK“.

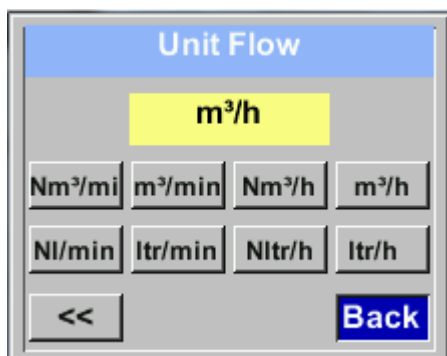

To the selected measurement value, a corresponding / appropriate unit needs to be defined. Select „Unit“ with „>“ and open menu with „OK“.

Select required unit with „>“ and take over by pressing „OK“.

Here e.g. for the measurement value Flow, procedure for the other measurements values is analog.

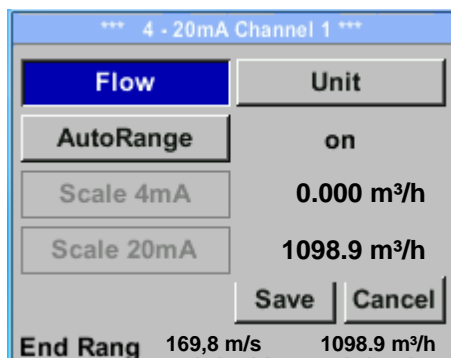

For saving the changes done press button „Save“ to discard the changes press button „Cancel“.

Leaving the menu with „Back“.

Settings → 4-20mA → Channel 1 → AutoRange

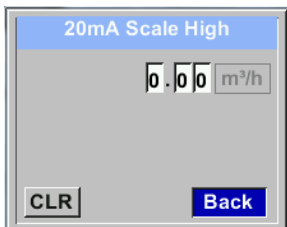
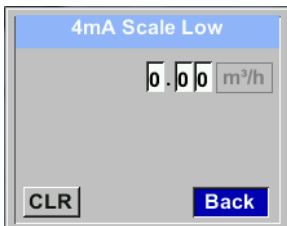
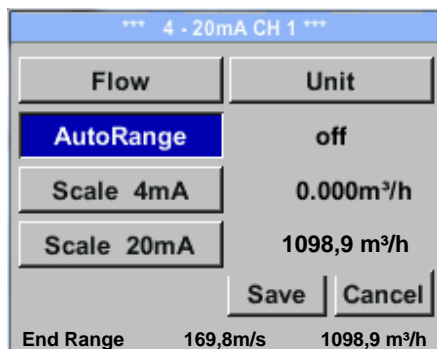

The scaling of the 4-20mA channel can be done automatically "Auto Range = on" or manual "AutoRange = off".

With button „>“ select the menu item „AutoRange“ select with „OK“ the desired scaling method. (Automatically or manually)

In case of **AutoRange = off** with „Scale 4mA“ and „Scale 20mA“ the scale ranges needs to be defined.

Select with button „>“ the item „Scale 4mA“ or „Scale 20mA“ and confirm with „OK“.

Input of the scaling values will be analogous as described before for value settings.

Using „CLR“ clears up the complete settings at once.

For „Auto on“, the max. scaling is calculated based on the inner tube diameter, max. measurement range and the reference conditions settings.

Take over of the inputs with „Save“ or discard the changes with **Cancel**

Leaving the menu with „Back“.

Settings → 4-20mA → Error Current

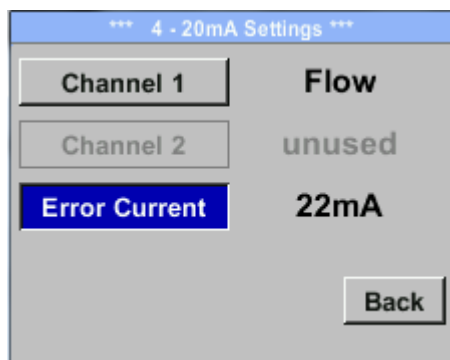

This determines what is output in case of an error at the analog output.

- 2 mA Sensor error / System error
- 22 mA Sensor error / System error
- None Output according to Namur (3.8mA – 20.5 mA)  
 < 4mA to 3.8 mA Measuring range under range  
 >20mA to 20.5 mA Measuring range exceeding

To make changes first select a menu item "Current Error" with button „>“ and then select by pressing the „OK“ the desired mode

For saving the changes done press button „Save“ to discard the changes press button **Cancel**.

Leaving the menu with „Back“.

**Remark:** Default setting for VU 570 analogue output is Channel 1:0,3...max. speed [m/s]  
 Default settings for VU 570 with option board analogue output Channel 1:0,3...max. speed [m/s]  
 Channel 2: -20°C ... 100°C]

For max. speed see label on Sensor.

### 11.3.8 VU 570 Info

Settings → Info

*** Info ***	
<b>Produktions Daten</b>	
SerienNr.: 1234567890	<a href="#">Details</a>
Kal. Datum: 10.01.2013	
<b>Sensor Daten</b>	
Sensor Type: CSFlow1 1.8	
Max. Geschw.	0.0m/s      0.0m³/h
Max. Temp.	100.0 °C
<b>Betriebs Daten</b>	
Laufzeit: 0T 0S 00M 00S	
UIn: 0.0 V	Temp. °C
<a href="#">zurück</a>	

*** Kalibrier Details ***	
<b>Kalibrier Bedingungen</b>	
Ref. Druck	1000.00 mbar
Ref. Temp	20.0°C
Durchmesser	53.1 mm
Druck	6000.00 mbar
Temperatur	24.0°C
Ausführung	Standard
<a href="#">zurück</a>	

Kurze Beschreibung der Sensordaten incl. der Kalibrierungsdaten.

Unter **Details** erhält man zusätzlich die Kalibrierbedingungen.

## 11.4 MBus

### 11.4.1 Change communication settings

The communication settings Primary-address and baud rate could be changed directly at the sensor, in case sensor has a display, or with the CS Service software (Order-No. 0554 2007).

#### Settings → M-Bus

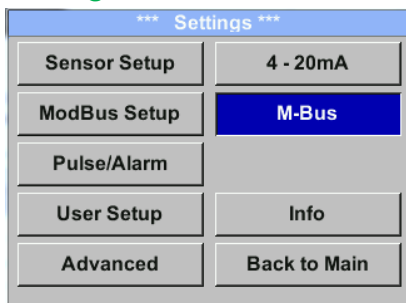

#### Settings → M-Bus → Adr

Possible inputs are values from 1-255 (Default setting = 1)

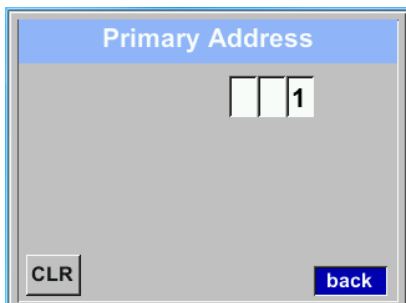
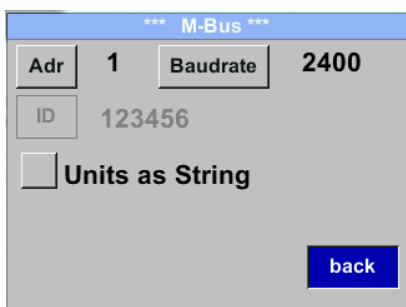

With „>“ select the button „Adr“ and confirm it with „OK“.

Select the desired position by pressing the button „△“ and select it with "OK" button.

Change values by pressing „>“ with step of 1, taking the value by confirming with "OK". Move to next position with „>“

Using „CLR“ clears up the complete settings at once.

For saving the changes done press button „Save“ to discard the changes press button "Cancel".

Leaving the menu with „Back“.

**Remark:** Secondary address "ID" is not changeable the ID is fixed.

#### Settings → M-Bus → Baudrate

Possible values are 2400, 4800 and 9600 Baud (Default setting = 2400).

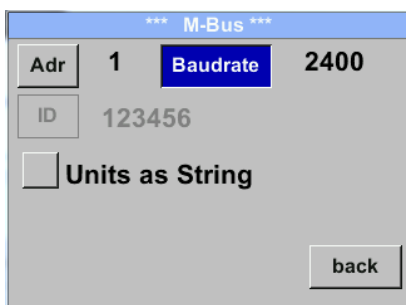

Baudrate change by pressing the button „OK“

For saving the changes done press button „Save“ to discard the changes press button "Cancel".

Leaving the menu with „Back“.

### 11.4.2 Coding VIF (Value Information Field)

\*\*\* M-Bus \*\*\*

Adr 1 Baudrate 2400

ID 123456

Units as String

back

\*\*\* M-Bus \*\*\*

Adr 1 Baudrate 2400

ID 123456

Units as String

Save Cancel

The Sensor offers two possibilities for coding the Value Information Field (VIF).

- Primary VIF (The units and multiplier correspond to MBus specification 4.8 chapter 8.4.3
- Plain text VIF ((units are transmitted as ASCII characters. So units that are not included in MBus specification chapter 8.4.3 are possible
- 

Switch to Plain Text VIF by activation of „Units as String“.

### 11.4.3 Default Settings communication

Primary Address\*: 1  
 ID: Serial number of Sensor  
 Baud rate\*: 2400  
 Medium\*: depending on medium (Gas or Compressed Air)  
 Manufacturer ID: CSI  
 VIF coding: Primary VIF

Both addresses, Primary address and ID, could be searched in the M-Bus system automatically.

### 11.4.4 Default values transmitted

Value 1 with [Unit]\*: Consumption [m<sup>3</sup>]  
 Value 2 with [Unit]\*: Flow [m<sup>3</sup>/h]  
 Value 3 with [Unit]\*: Gas temperature [°C]

\*All Values could be changed / pre-set in production or with CS Service software (Order-No. 0554 2007)



## 12 Status / Error messages

### 12.1 Status messages

- CAL

CS Instruments GmbH & Co.KG recommends a regular re-calibration, see chapter 13.

This means that the date at which the next recalibration is recommended is entered internally on delivery.

When this date is reached, the status message "Ca" is displayed.

**Note:** Measurement continues without interruption or restriction.

**Status message:**

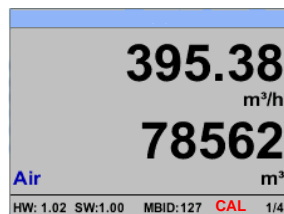

## 12.2 Error messages

- **Low Voltage**

If the supply voltage is lower than 11V, the warning message "**Low Voltage**" is displayed.

This means that the sensor can no longer work / measure properly and therefore no measured values for measured values for flow rate, consumption, speed, pressure and temperature are available.

- **Internal Error**

In case of this message "**Internal Error**" the sensor has detected an internal read error on e.g. EEPROM, AD converter etc..

- **Temp out of Range**

In case of media temperatures outside the specified temperature range, the status message „**Temp out of Range**" status message.

This leads to incorrect measured values (outside the sensor specification).

- **Low Voltage 4-20mA**

Sensors with a galvanically isolated 4-20mA output require a minimum supply voltage of 17.5V. If this is not reached, the error message "**Low Voltage 4-20mA**" is displayed.

**Error messages:**

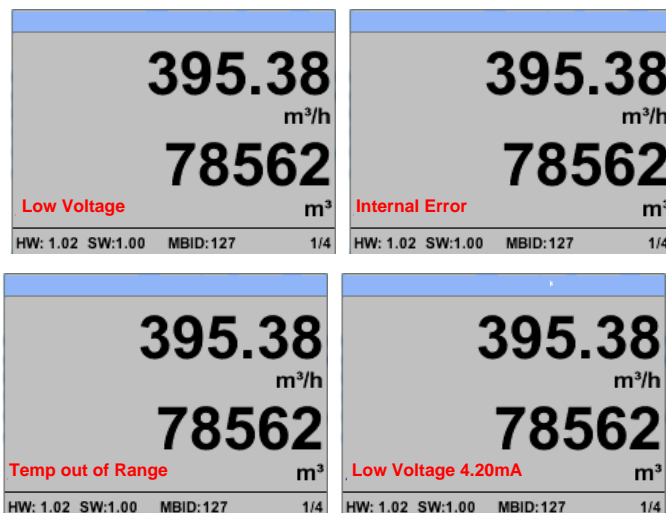

## 13 Maintenance

The sensor head must be checked regularly for dirt and cleaned if necessary. Deposits of dirt, dust or oil will cause a measured value deviation.

Checking is recommended annually; if the compressed air is heavily contaminated, the checking interval is reduced.

## 14 Re-Calibration

If no customer specifications have been made, we recommend a calibration interval of 12 months. The sensor must be sent to CS Instruments for this purpose.

## 15 Spare parts and repair

Spare parts are not available for reasons of measuring accuracy.

In case of defects, the sensors must be sent to the supplier for repair.

When using the measuring instruments in plants which are important for operation, we recommend keeping a spare measuring system on hand.

## 16 Calibration

Within the scope of DIN ISO certification, we recommend having the measuring instruments calibrated and, if necessary, adjusted at regular intervals. The calibration cycles should be based on your internal specifications. Within the scope of DIN ISO certification, we recommend a calibration cycle of one year for the VU 570.

On request, calibration certificates can be issued for a fee. Here, the precision is given and verifiable by DKD-certified volumetric flow meters.

## 17 Warranty

Defects which are demonstrably due to a factory defect will of course be repaired free of charge. The prerequisite is that you report this defect immediately upon discovery and within the warranty period granted by us. Damage caused by improper use or by non-compliance with the operating instructions is excluded from this warranty.

are excluded from this warranty.

The warranty is also void if the measuring device has been opened - unless this is expressly described in the operating instructions for maintenance purposes - or if serial numbers in the device have been changed, damaged or removed.

The warranty period for VU 570 consumption meters is 12 months. Unless otherwise defined, 6 months apply to accessories. Warranty services do not cause an extension of the warranty period. If necessary, repairs, adjustments or the like have been carried out in addition to the warranty service, the warranty services are free of charge, but the other services will be charged, as will transport and packaging. Further or other claims, especially in case of damages not concerning the device, are excluded - as far as liability is not mandatory by law.

### Services after the warranty period

Of course, we are also there for you after the warranty period has expired. In case of malfunctions, please send us your measuring device with a short description of the error.)