

VA 550 - Flow meter insertion type

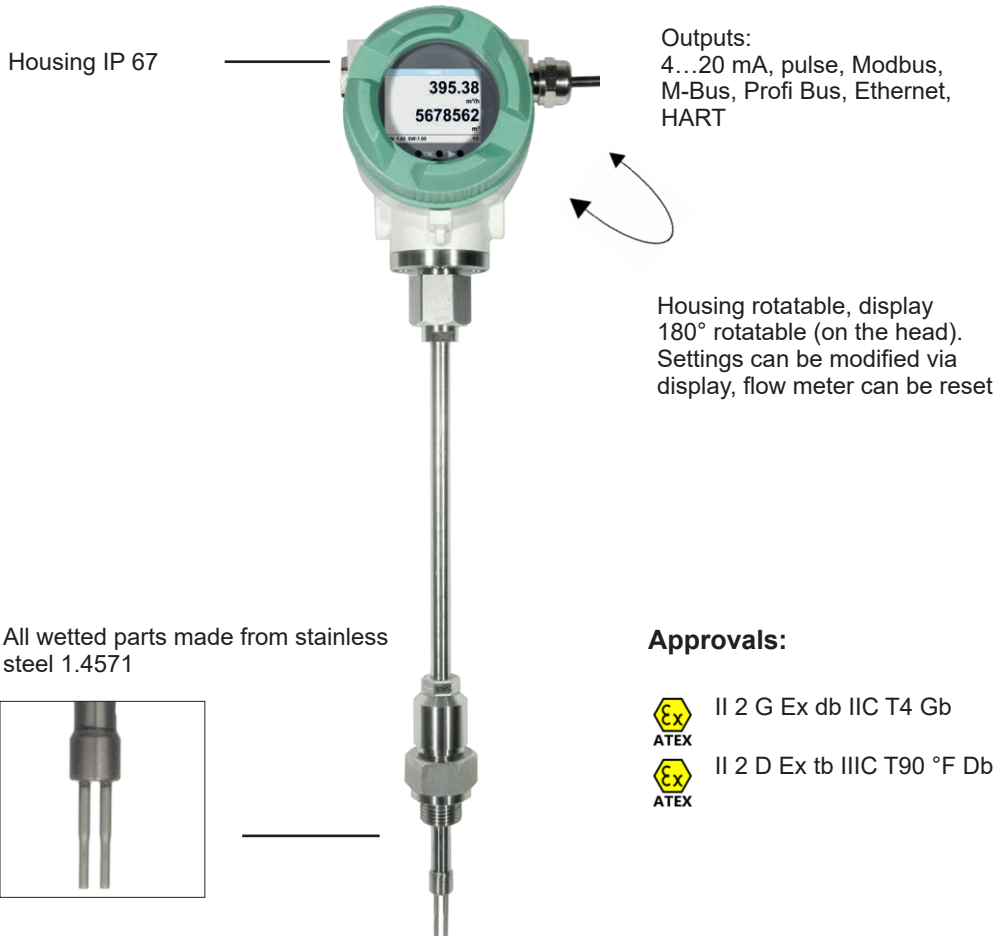

Flow sensor for installation in existing compressed air or gas line of 3/4" to 40"



Advantages of optical keys:

The sensor can also be config-
ured in the ATEX area, without
the housing needing to be
opened.

Approvals:

- II 2 G Ex db IIC T4 Gb
- II 2 D Ex tb IIIC T90 °F Db



The sensor can
be removed and
cleaned

Special measurement technology features:

- 4 values on the display: Flow, total consumption, velocity, temperature. Units freely adjustable
- All measured values, settings such as gas type, inner diameter, serial number and so on can be accessed via Modbus-RTU
- Comprehensive diagnostic functions readable on the display or remote access via Modbus such as calibration cycle, error codes, serial number
- Notification in case of exceeding the calibration cycle
- Standard version accuracy 1.5% of m.v. ± 0.3% of f.s.
- Precision version accuracy 1.0% of m.v. ± 0.3% of f.s.
- Measuring span of 1 : 1000 (0.33 ft/s up to 735 ft/s)
- Configuration and diagnosis via display, hand-held device PI 500, PC service software on-site
- Gas type (air, nitrogen, oxygen, argon and so on) freely adjustable via PC service software or external device DS 400, DS 500, PI 500
- Reference conditions °F and mbar/hPa freely adjustable
- In-Situ adjustment, leak flow volume suppression
- Pressure loss negligible

Special mechanical features:

- Robust impact-proof aluminum die cast housing for the outdoor area IP 67
- All wetted parts made from stainless steel 1.4571
- Suitable as an insertion version for 3/4" to 40"
- On request with DVGW approval for natural gas (up to 232 psi)
- Pressure range up to 725 psi, special version up to 1450 psi
- Temperature range up to -356 °F
- No moveable parts, no wear
- Sensor tip very robust, easy to clean
- Easy installation and removal under pressure via 1/2" ball valve
- Housing rotatable, display rotatable by 180°
- Safety ring for installation and removal under pressure
- Depth scale for precise installation

Easy mounting/dismounting of VA 550 under pressure - without disconnection of the line - without emptying the line

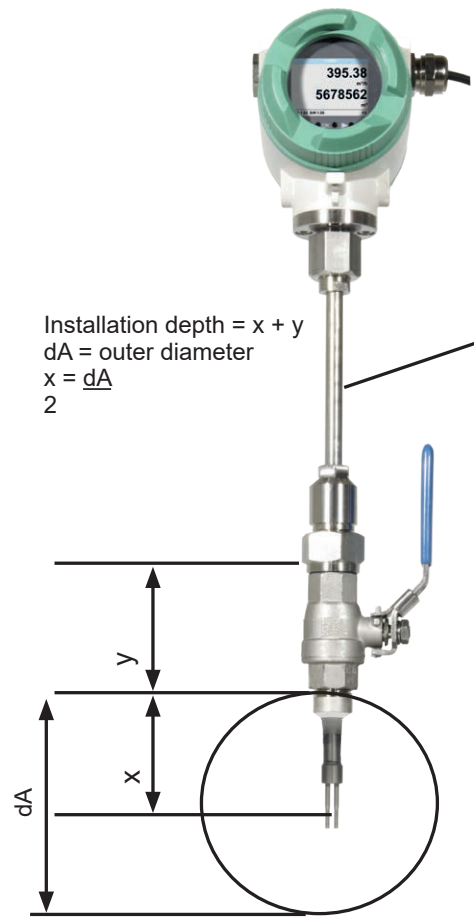

Installation depth = x + y
 dA = outer diameter
 $x = \frac{dA}{2}$

Engraved depth scale for precise installation

180
170
160

If there is no suitable measuring site with 1/2" ball valve, there are two simple possibilities to set up a measuring site:

- A** Weld on a 1/2" screw neck and screw on a 1/2" ball valve
- B** Mount spot drilling collar including ball valve

By means of the drilling jig, it is possible to drill under pressure through the 1/2" ball valve into the existing pipe. The drilling chips are collected in a filter. Then the probe can be mounted.



A Screw neck

Order no.: 3300 0006



B Spot drilling collars

Order no.: see page 106



Drill under pressure with the CS drilling jig
 Order no.: 0530 1108



Optional: Connection to different Bus systems

There are different options available for connection to modern Bus systems:

- Ethernet interface (Modbus-TCP) / PoE
- M-BUS
- Modbus-RTU
- Profibus DP interface (in process)
- Profinet interface (in process)
- HART (in process)



Ethernet Modbus TCP
 M12 Ethernet port, x-coded

For further accessories refer to pages 102 to 106

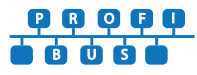

VA 550 - Flow meter insertion meter

Example order code VA 550:

0695 0550_A1_B1_C1_D1_E1_F1_G1_H1_I1_J1_K1_L1_M1_R1

Measuring range (see table page 110 to 113)	
A1	Standard version (304 ft/s)
A2	Max version (607 ft/s)
A3	High-speed version (735 ft/s)
A4	Low-speed version (164 ft/s)

Screw-in thread	
B1	G 1/2" male thread
B2	1/2" NPT male thread

Installation length / shaft length	
C1	220 mm
C2	300 mm
C3	400 mm
C4	500 mm
C5	600 mm
C6	700 mm (not with ATEX)
C7	160 mm
C8	1000 mm (not with ATEX)
C9	1500 mm (not with ATEX)

Display option	
D1	with integrated display
D2	without display

Signal outputs / bus connection option	
E1	2 units 4...20 mA analog output (electrically isolated), pulse output, RS 485 (Modbus-RTU)
E4	1 x 4...20 mA analog output (not electrically isolated), pulse output, RS 485 (Modbus-RTU)
E5	Ethernet interface (Modbus / TCP), 1 x 4...20 mA analog output (not electrically isolated), pulse output, RS 485 (Modbus-RTU)
E8	M-Bus, 1 x 4...20 mA analog output (not electrically isolated), pulse output, RS 485 (Modbus-RTU)
E9	Ethernet interface PoE (Power over Ethernet) (Modbus/ TCP), 1 x 4...20 mA analog output (not electrically isolated), pulse output, RS 485 (Modbus-RTU)

Adjustment / calibration	
F1	No real gas adjustment - gas type configuration per gas constant
F2	Real gas adjustment in the gas type selected below

Gas type	
G1	Compressed air
G2	Nitrogen (N2)
G3	Argon (Ar)
G4	Carbon dioxide (CO2)
G5	Oxygen (O2)
G6	Nitrous oxide (N2O)
G7	Natural gas (NG)
G8	Helium (He) (real gas adjustment F2 required)
G9	Propane (C3H8) (real gas adjustment F2 required)
G10	Methane (CH4)
G11	Biogas (methane 50% : CO2 50%)
G12	Hydrogen (H2) (real gas adjustment F2 required)
G90	Further gas / please indicate gas type (on request)
G91	Gas mixture / please indicate mixture ratio (on request)

Maximum pressure (more than 10 bar high-pressure protection required!)	
H1	725 psi
H2	1450 psi
H3	232 psi

Surface condition	
I1	standard version
I2	special cleaning - oil and grease free (e.g. for oxygen applications and so on)
I3	Silicone-free version including special cleaning oil- and grease-free

Accuracy class	
J1	± 1.5% of the measured value ± 0.3% f.s. (standard)
J2	± 1% of the measured value ± 0.3% f.s. (precision)

Maximum gas temperature on the sensor tip	
K1	up to 248 °F gas temperature (only for ATEX version)
K2	up to -356 °F gas temperature (standard)

Approvals	
L1	Non-explosive area - no approval
L2	ATEX II 2G Ex db IIIC T4 Gb ATEX II 2D Ex tb IIIC T90 °C, Db
L3	DVGW approval for natural gas (max. pressure 232 psi)

Reference standard	
M1	68 °F, 14.5 psi
M2	32 °F, 14.7 psi
M3	59 °F, 14.2 psi
M4	59 °F, 14.7 psi

Special measuring range	
R1	Special measuring range (please specify when placing order)

Order no. VA 550

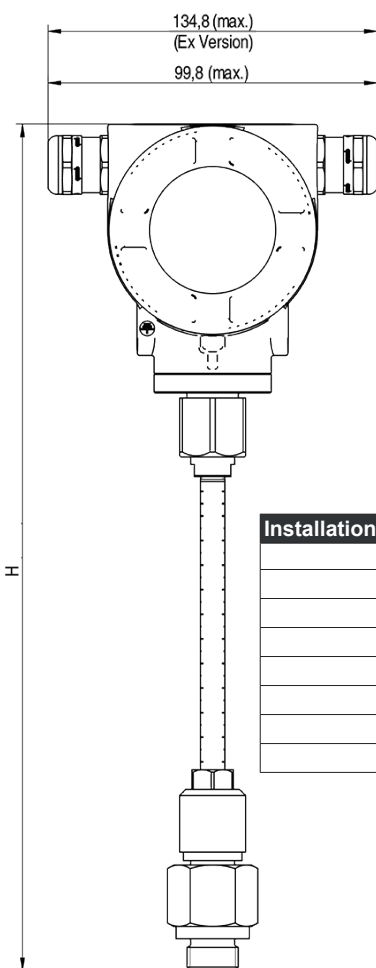

Installation/shaft length	L	H
C1	220	441
C2	300	521
C3	400	621
C4	500	721
C5	600	821
C7	160	381
C8	1000	1221
C9	1500	1721

Further accessories:

DESCRIPTION	ORDER NO.
Connection cable for probes 16 ft with open ends	0553 0108
Connection cable for probes 32.81 ft with open ends	0553 0109
Ethernet connection cable length 16 ft, M12 plug x-coded (8 pin) to RJ 45 plug	0553 2503
Ethernet connection cable length 32.81 ft, M12 plug x-coded (8 pin) to RJ 45 plug	0553 2504
Mains unit in wall housing for maximum 2 sensors of the series VA/FA 5xx, 100-240 V, 23 VA, 50-60 Hz / 24 VDC, 0.35 A	0554 0110
ISO calibration certificate at 16 ft measuring points for VA 500/550	3200 0001
Additional calibration point for volume flow (point freely selectable)	0700 7720
CS Service Software VA 550 incl. interface cable to PC (USB) and power supply - for configuration / parametrization of VA 550	0554 2007
High-pressure protection recommended for installation from 145 to 1450 psi (for VA 550)	0530 1115
High-pressure protection recommended for installation from 145 to 232 psi DVGW (for VA 550)	0530 1116
PNG cable screwing - standard VA 550/570	0553 0552
PNG cable screwing - for ATEX version VA 550/570	0553 0551

DESCRIPTION	ORDER NO.
VA 550 Flow meter, measuring head in robust aluminum die casting housing	0695 0550 + Order code A_...R_

TECHNICAL DATA VA 550

Measuring range VA 550:	up to 164 ft/s, low-speed version* up to 304 ft/s, standard version* up to 607 ft/s, max. version* up to 735 ft/s, high-speed version*
	* Measuring range SCFM for different pipe diameters and gases, see table measuring ranges flow * All measured values related to DIN 1343 standard conditions 0° and 1013 mbar ex works
Accuracy: Accuracy class (o. M. V. = of measured value) (o. F. S. = of full scale)	± 1.5 % of m.v. ± 0.3 % of f.s. on request: ± 1.0 % of m.v. ± 0.3 % of f.s.
Accuracy indications:	relative to ambient temperature 71.6 °F ± 2 °F, system pressure 87 psi
Repeatability:	0.25 % of m.v. in case of correct mounting (mounting aid, position, inlet section)
Measuring principle:	Thermal mass flow sensor
Response time:	t 90 < 3 s
Operating temperature range sensor tube/display unit:	-40...356 °f standard version, sensor tube -4...158 °F display unit -4...248 °F for ATEX version
Adjustment possibilities via display, external handheld device PI 500, PC Service Software, remote diagnosis:	Nm³/h, Nm³/min, NI/min, l/s, ft/min, cfm, kg/h, kg/min, inner diameter, reference conditions °F / °C, psi/hPa, zero point correction, leak flow volume suppression, scaling analog output 4...20 mA, pulse/alarm, error codes etc.
Outputs:	Standard: 1 x 4...20 mA analog output (electrically not isolated), pulse output, RS 485 (Modbus-RTU) Optional: 2 x 4...20 mA active, Modbus TCP, HART, Profibus DP, Profinet, M-Bus
Burden:	< 500 ohm
Additional average value calculation:	for all parameters freely adjustable from 1 minute up to 1 day, e. g. 1/2 hours average value, average day value
Protection class:	IP 67
Material:	Die-cast aluminum housing, sensor tube stainless steel 1.4571
Screw-in thread:	G 1/2" ISO 228, NPT 1/2", R 1/2", PT 1/2"
Operating pressure VA 550:	50 bar, in special version 1450 psi (with DVGW approval max. 232 psi)
Power supply:	18...36 VDC, 5 W
Approval:	ATEX II 2G Ex db IIC T4 Gb, ATEX II 2D Ex tb IIC T90 °C, Db, DVGW